

Port of Astoria Pier 2
Results of Inspection 9/2015 & 1/2016, 9/2016

Current totals as of 9/15/2016

Updating as of 10/7/2016

Note: Replaced sections/ columns highlighted orange
Need Deck Assessment from Gerrard/Swanstrom

Bents with Good Land Access

	Timber Cap (lf)				Timber Pile (each)				Timber column (each)				Timber Girder (lf)				RC Deck (sf)				Steel Cap (lf)				Steel pile(each)				
	CS1	CS2	CS3	CS4	CS1	CS2	CS3	CS4	CS1	CS2	CS3	CS4	CS1	CS2	CS3	CS4	CS1	CS2	CS3	CS4	CS1	CS2	CS3	CS4	CS1	CS2	CS3	CS4	
#22527																													
Bt F - A	534	122	14	35	56	2	0	1	18	2	0	0	1530	240	0	0	2680		50	0	0	0	0	0	0	0	0	0	
Bt 1 - 50	4878	1081	56	90	729	39	37	23	419	4	37	10	17995	3757	8	0	23856		750	0	0	0	30	0	0	0	1	0	0
Bt 51 - 84	6469	0	10	36	643	1	10	25	441	0	12	10	15012	0	0	0	17808		0	0	0	0	10	0	0	0	20	0	0
Totals	11347	1081	66	126	1372	40	47	48	860	4	49	20	33007	3757	8	0	41664		750	0	0	0	40	0	0	0	21	0	0

27	40	66	87
103	Access hatch in deck		
118	287 Access through Hole		

	Timber Cap (lf)				Timber Pile (each)				Timber column (each)				Timber Girder (lf)				RC Deck (sf)				Steel Cap (lf)				Steel pile(each)				Steel column (each)				
	CS1	CS2	CS3	CS4	CS1	CS2	CS3	CS4	CS1	CS2	CS3	CS4	CS1	CS2	CS3	CS4	CS1	CS2	CS3	CS4	CS1	CS2	CS3	CS4	CS1	CS2	CS3	CS4	CS1	CS2	CS3	CS4	
#22452																																	
Bt 85 - 90	805	0	14	53	113	0	2	6	85	0	5	0	0	2592	0	0	0	0	3456	0	0	0	0	0	0	0	0	0	0	0	0		
Bt 91 - 110	3316	0	2	169	294	0	13	22	237	1	7	5	0	7464	0	0	0	0	7936	0	0	0	62	0	0	0	0	0	0	0	0		
Bt 111-146	5810	767	207	481	607	19	13	25	375	3	15	37	0	11292	28	8	0	0	22656	0	0	34	212	0	1	0	2	0	0	0	3	0	0
Bt 147-201	4246	6	8	64	709	82	50	17	0	0	0	0	0	23496	0	0	0	0	28518	10	0	30	343	10	0	2	2	0	0	5	7	5	0
Totals	13372	773	217	714	1610	101	76	64	612	4	22	42	0	42252	28	8	0	0	59110	10	0	64	617	10	1	2	4	0	0	5	10	5	0

	Timber Cap (lf)				Timber Pile (each)				Timber column (each)				Timber Girder (lf)				RC Deck (sf)				Steel Cap (lf)				Steel pile(each)				Timber Deck (sf)				
	CS1	CS2	CS3	CS4	CS1	CS2	CS3	CS4	CS1	CS2	CS3	CS4	CS1	CS2	CS3	CS4	CS1	CS2	CS3	CS4	CS1	CS2	CS3	CS4	CS1	CS2	CS3	CS4	CS1	CS2	CS3	CS4	
#22526																																	
Bt 202 - 232	0	4659	19	188	466	0	5	10	318	0	17	83	0	10030	50	0	0	0	15824	0	0	0	0	0	0	0	0	0	0	1258	0	86	
Bt 233 - 273	2626	0	267	1170	524	7	5	53	378	15	36	112	0	14672	40	96	0	0	1824	0	0	0	0	0	0	5	0	0	0	0	14442	36	526
Bt 274 - 308	0	6	134	742	437	21	1	41	257	6	26	86	0	12768	360	0	0	0	3858	0	0	0	0	0	0	9	0	0	0	0	11644	426	1020
Totals	2626	4665	420	2100	1427	28	11	104	953	21	79	281	0	37470	450	96	0	0	21506	0	0	0	0	0	0	14	0	0	0	0	27344	462	1632

NOTE: Bent #229 not used

Assumptions:

- 1 Timber Caps, Girders, Decks were in CS1 if not identified as anything worse.
- 2 Same for Steel Caps and piles and RC Deck; missing columns aren't counted
- 3 Timber Piles, Columns and Steel Piles were in CS1 if not identified as anything worse.

This may or may not be a reasonable assumption

It is based on the idea that we inspected many more piles than girders and caps

Note:

Posts & Caps are 14 x 14, Therefore 5x-4r-5x = CS2, 3x-8r-3x = CS3

Piles are 14" dia. Therefore 3x-8r-3x = CS3, 2x-10r-2x = CS3

10% Bearing loss considered CS2 for this purpose, >50% = CS4 (1 ft/ timber cap)

<\\7de7400c\SHARE\Port of Astoria>

If there's only one number,
Bent #, correct as of UW
Inspection: Aug-16

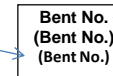

As labeled in field
Original Orange Paint and placards

As determined by lidar
(original dwg)

<\\7de7400g\share\AstoriaPier2\1-25-2016>

\\S7000b\BridgMgmt\Images_Other\Port Astoria 9 15 photos

\\S7000b\BridgMgmt\Images_Other\Port Astoria 1 16 photos

Port of Astoria Pier 2
 Results of Inspection 9/2015 & 1/2016

BEGIN BRIDGE 22452

Cross Bracing & Girders generally not pictured
 3-4 girders per pile. Girders are 13.5" x 6"
 Caps are 14" x 14"

Green Remaining Bearing
 Red Section Loss

#22452 1/4

Unless otherwise noted, piles & columns - CS1, caps & girders - CS2

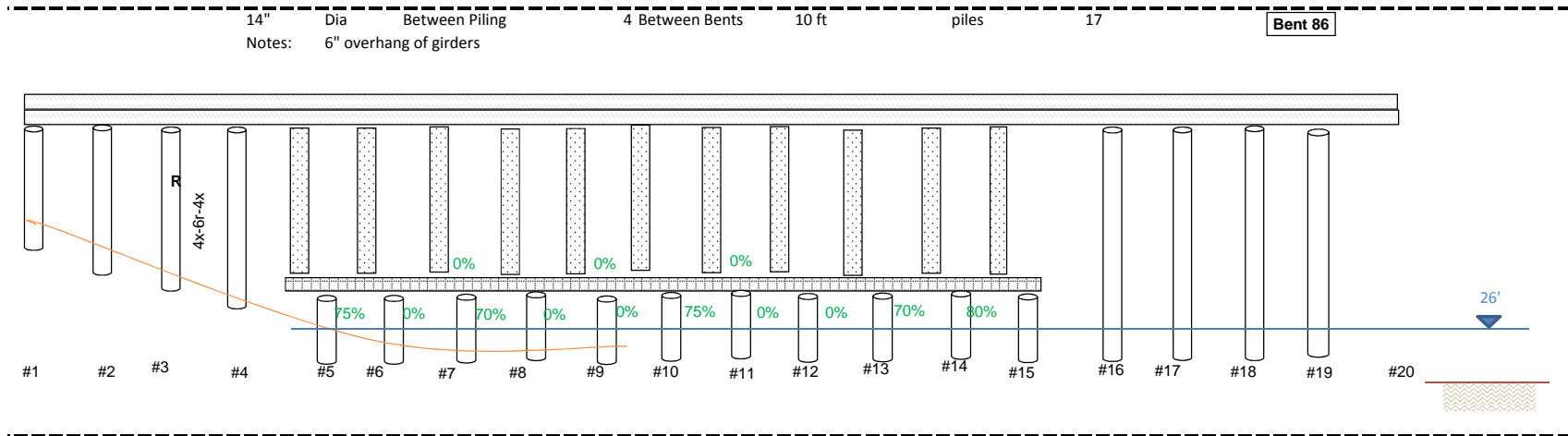
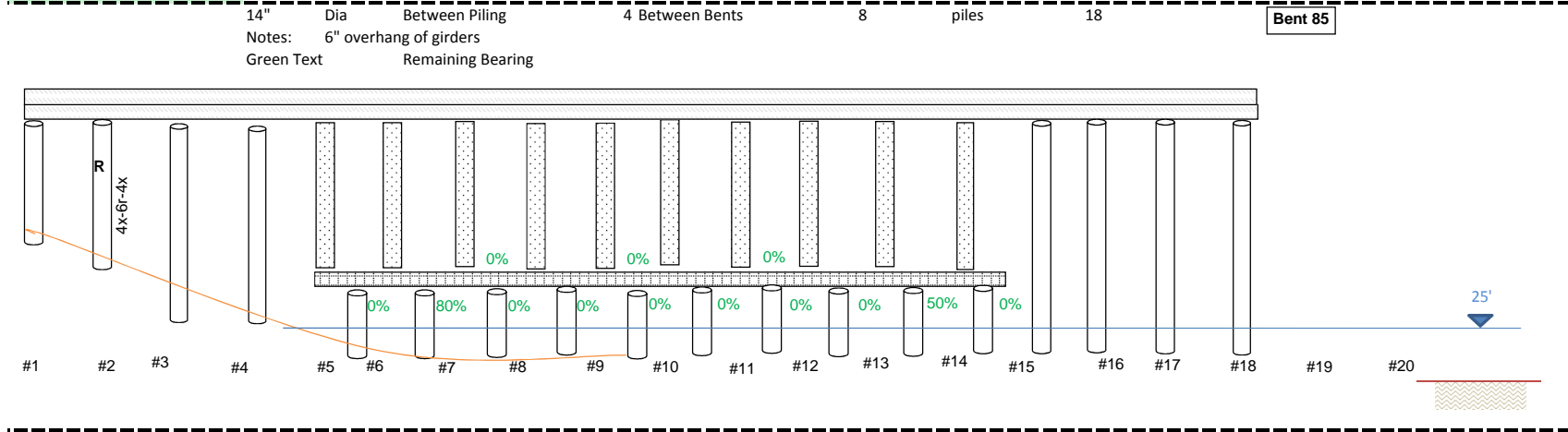

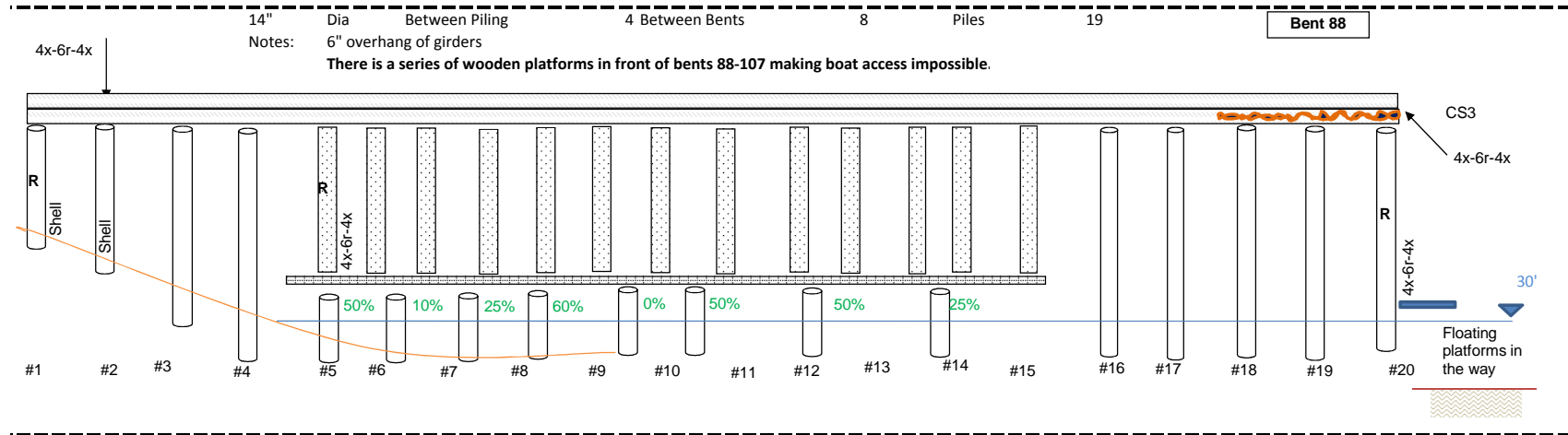
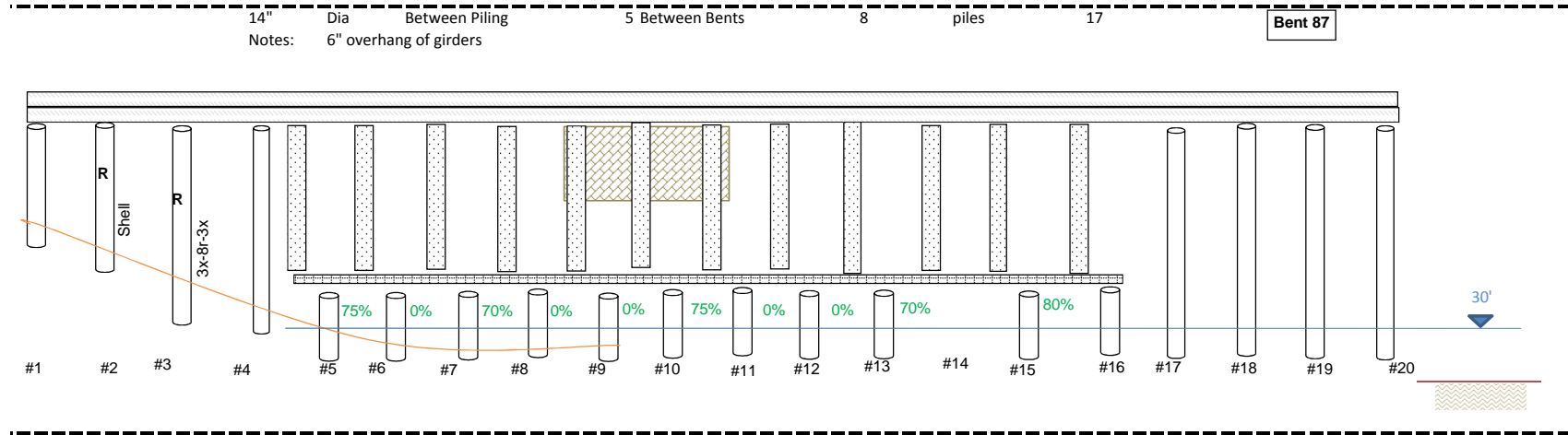

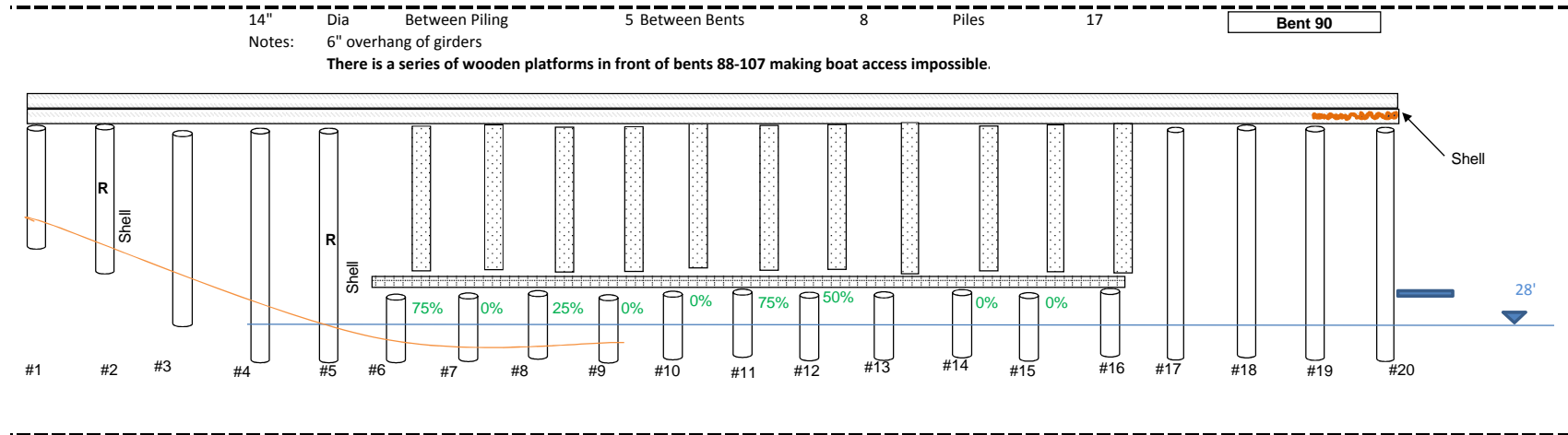
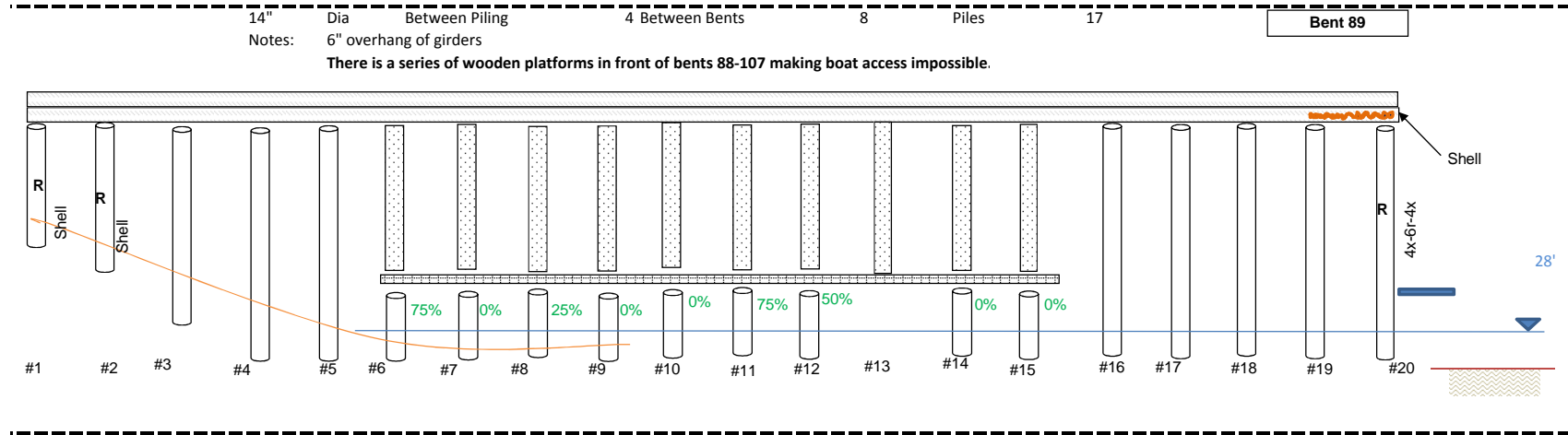

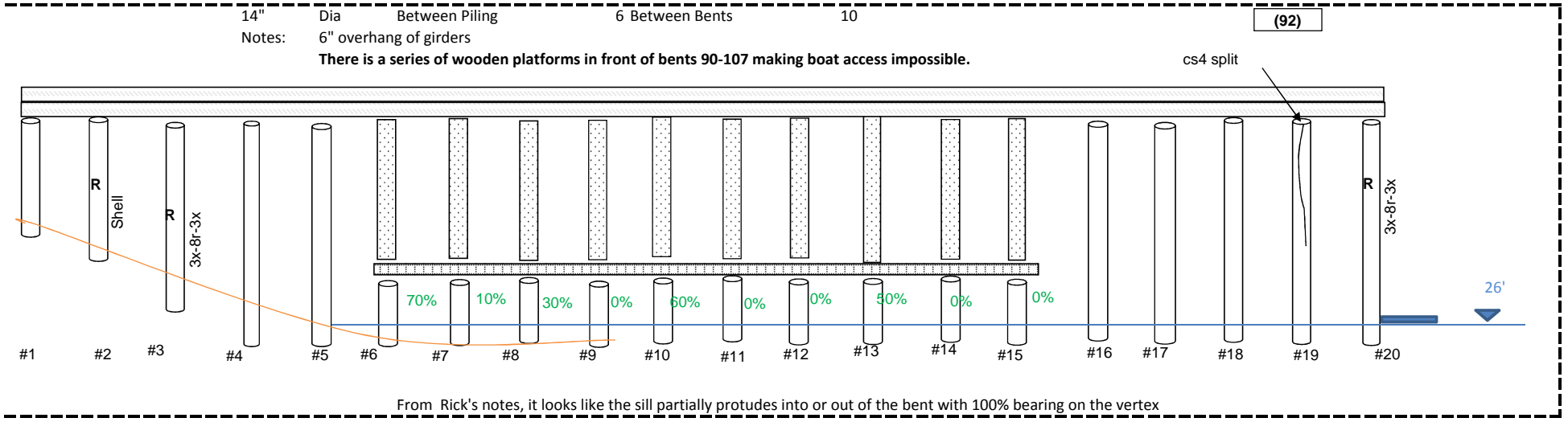
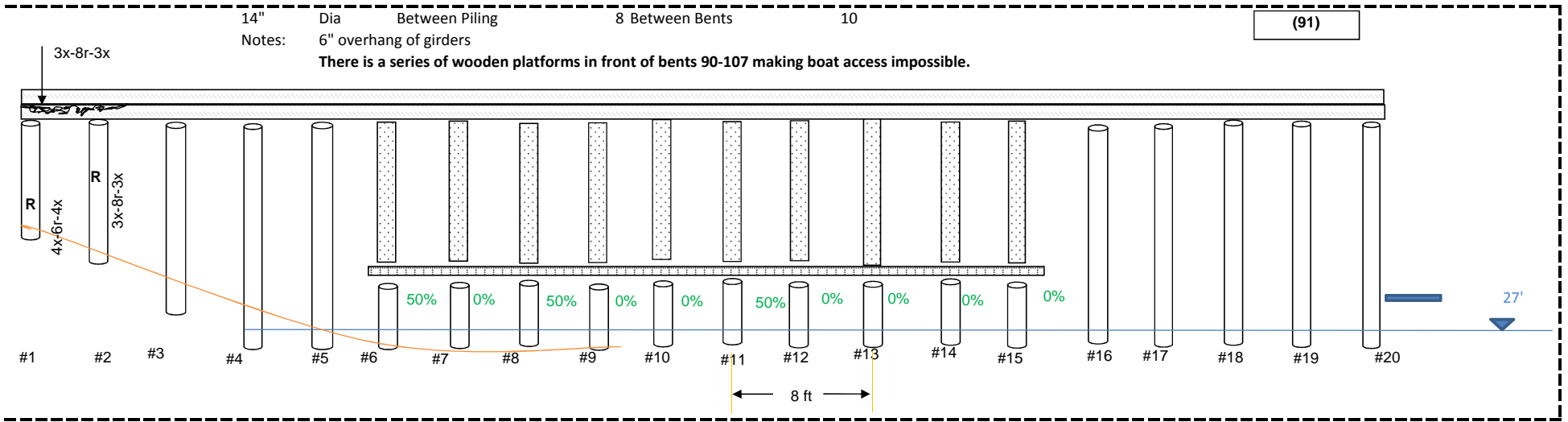

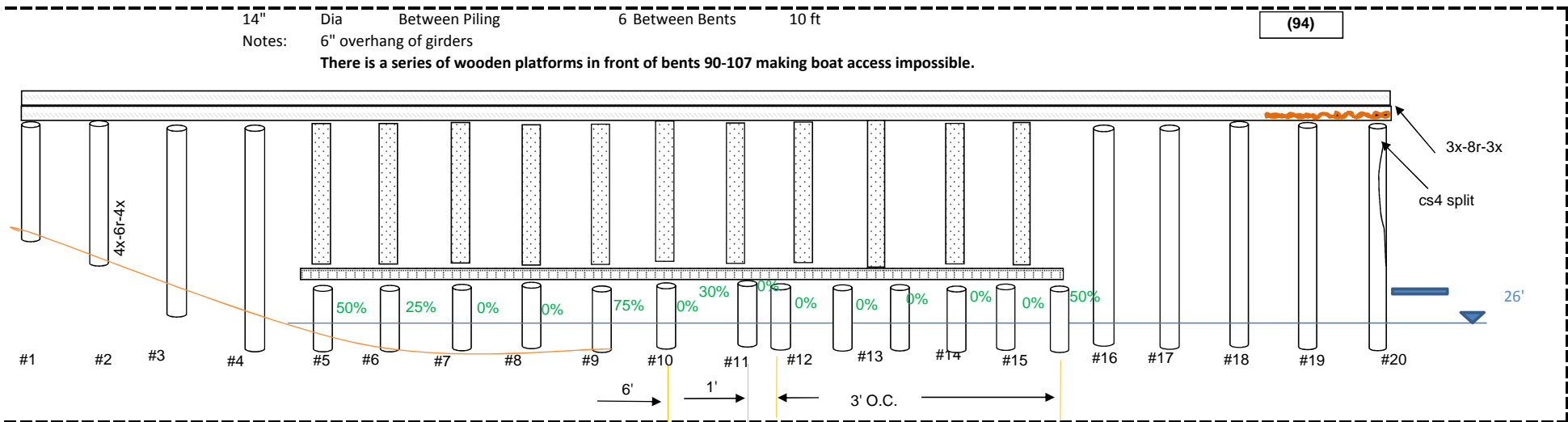
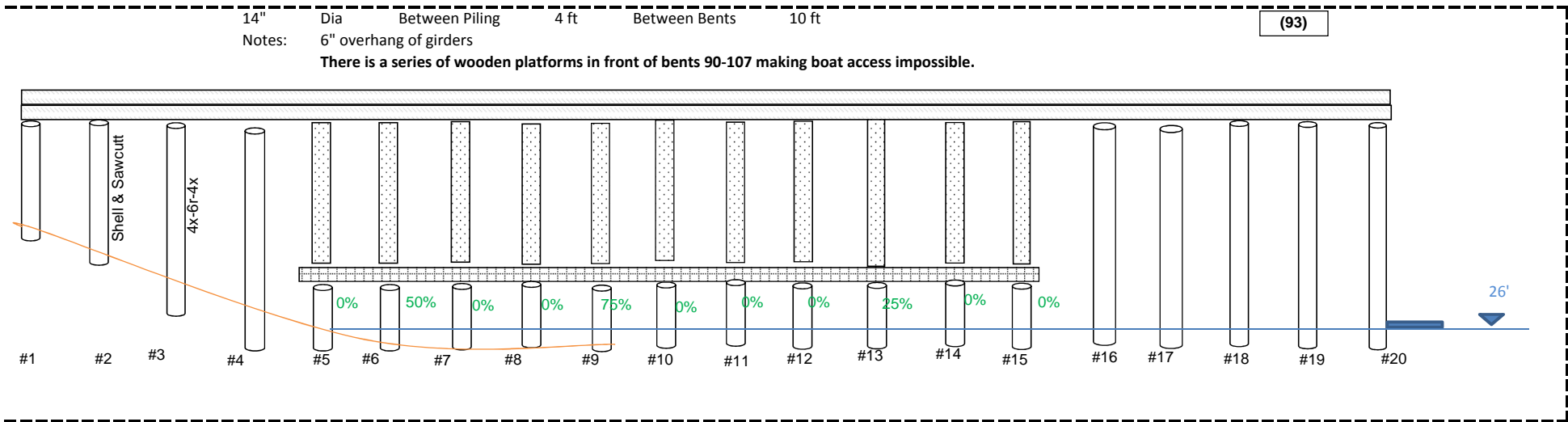

14" Dia Between Piling 4 ft Between Bents 10 ft

(95)

Notes: 6" overhang of girders
There is a series of wooden platforms in front of bents 90-107 making boat access impossible.

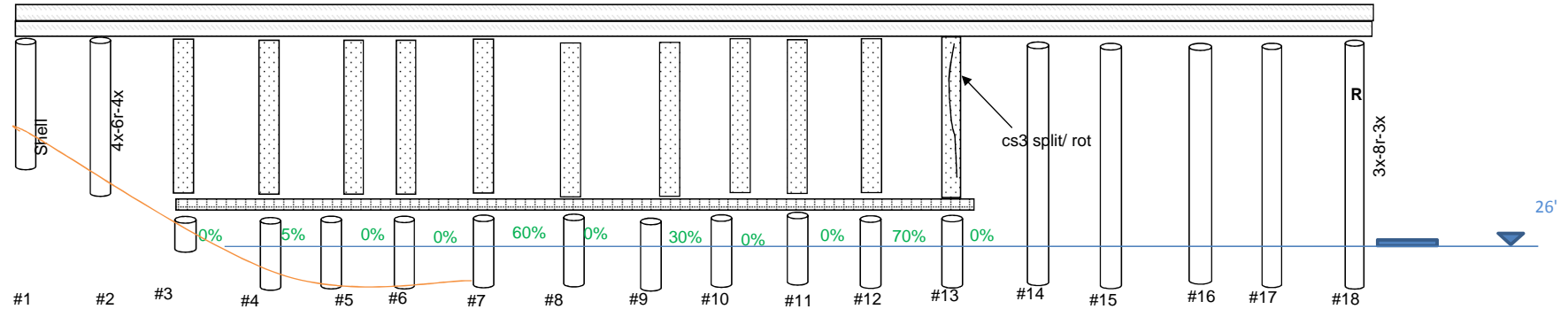

14" Dia Between Piling 4 Between Bents 10

(96)

Notes: 6" overhang of girders
There is a series of wooden platforms in front of bents 90-107 making boat access impossible.

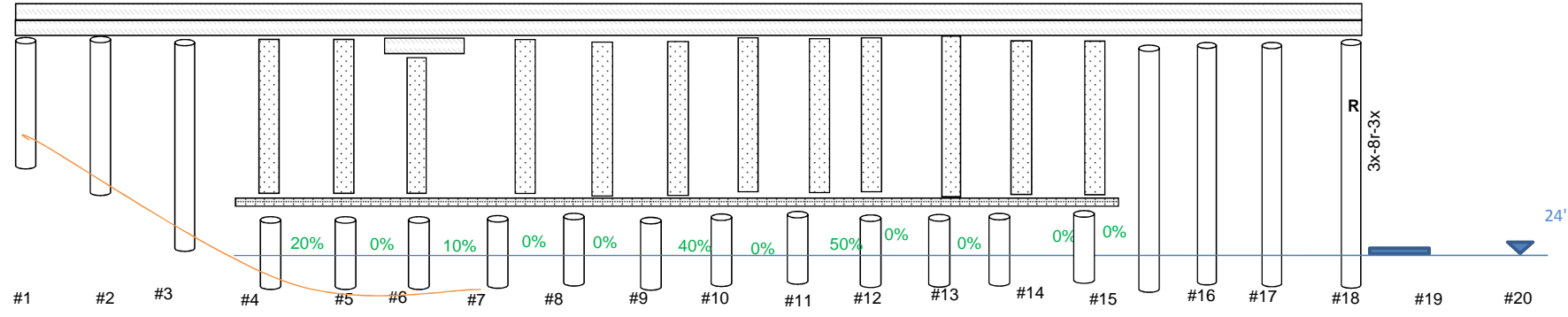

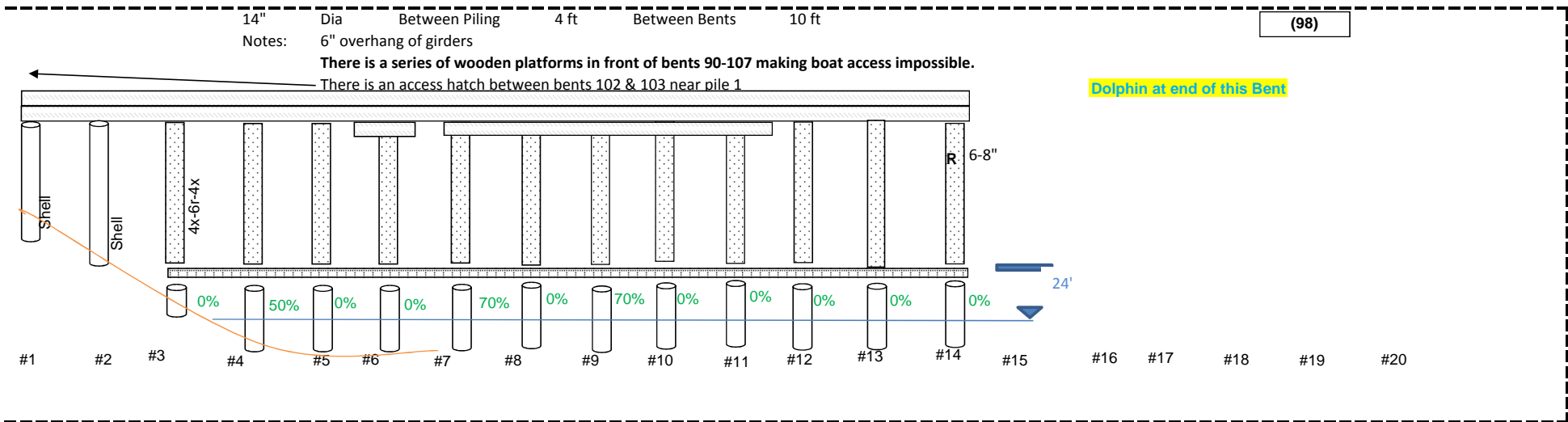
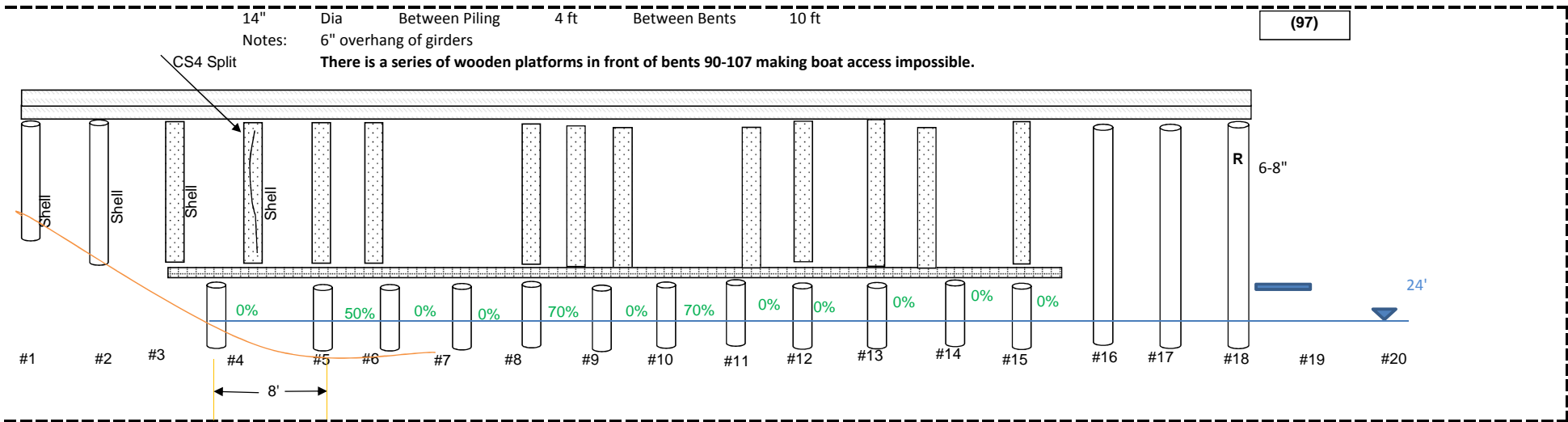

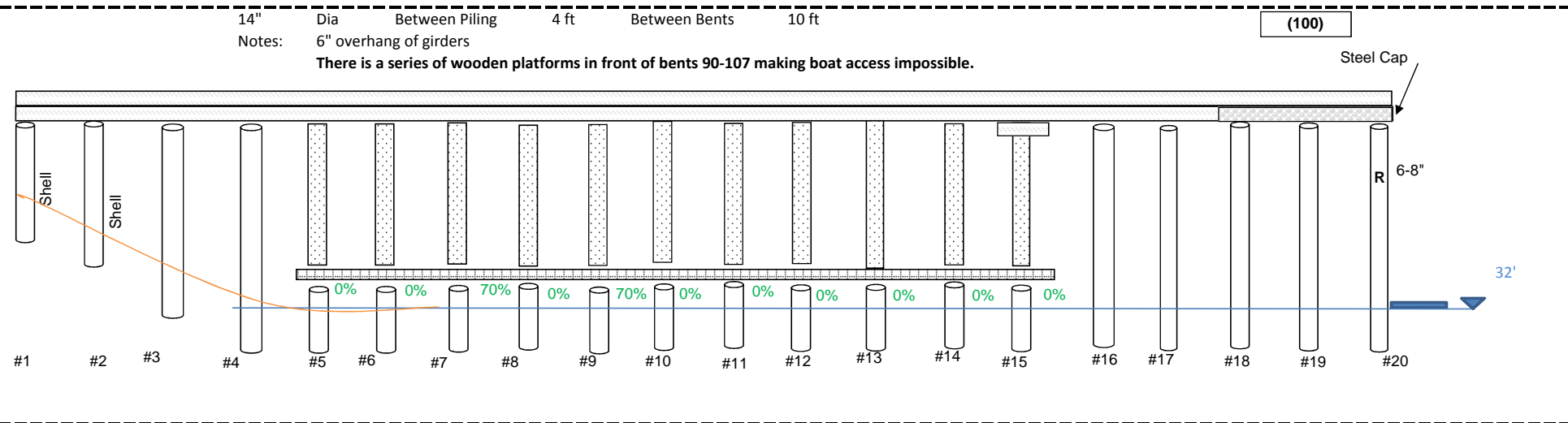
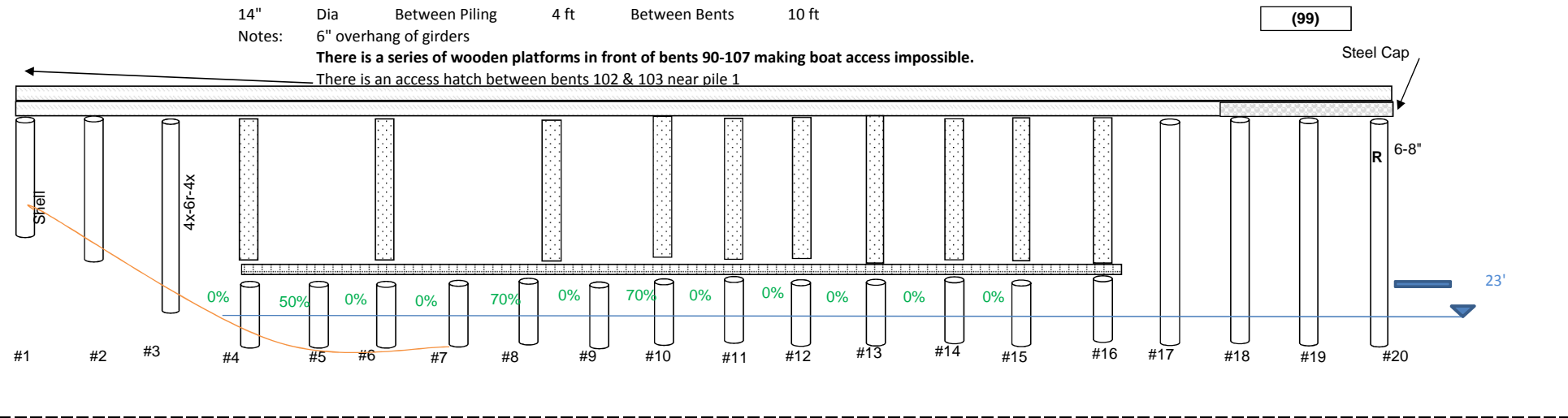

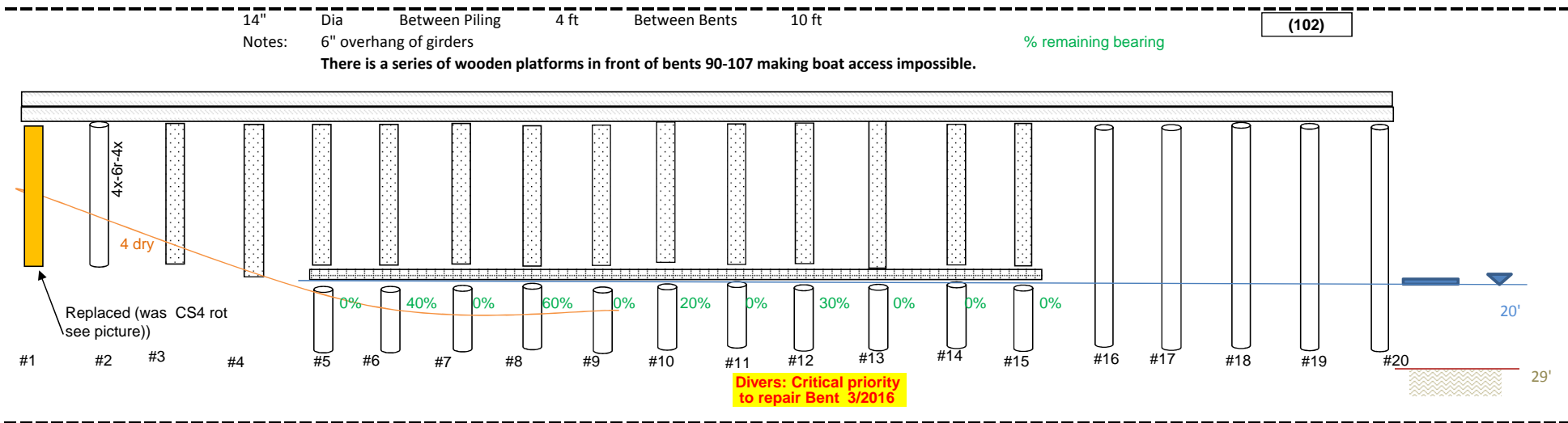
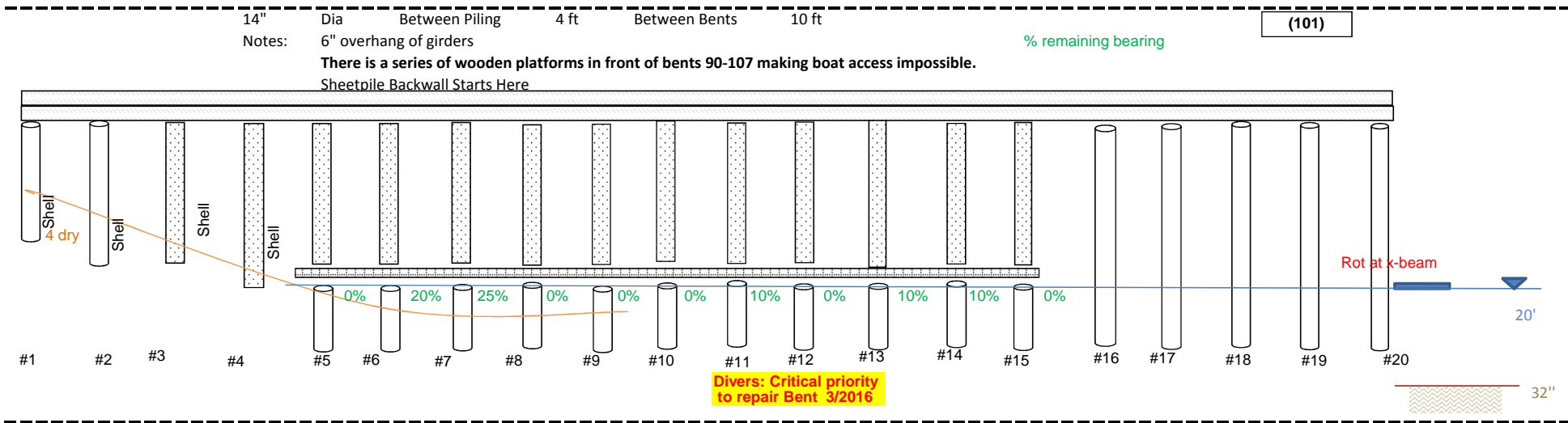

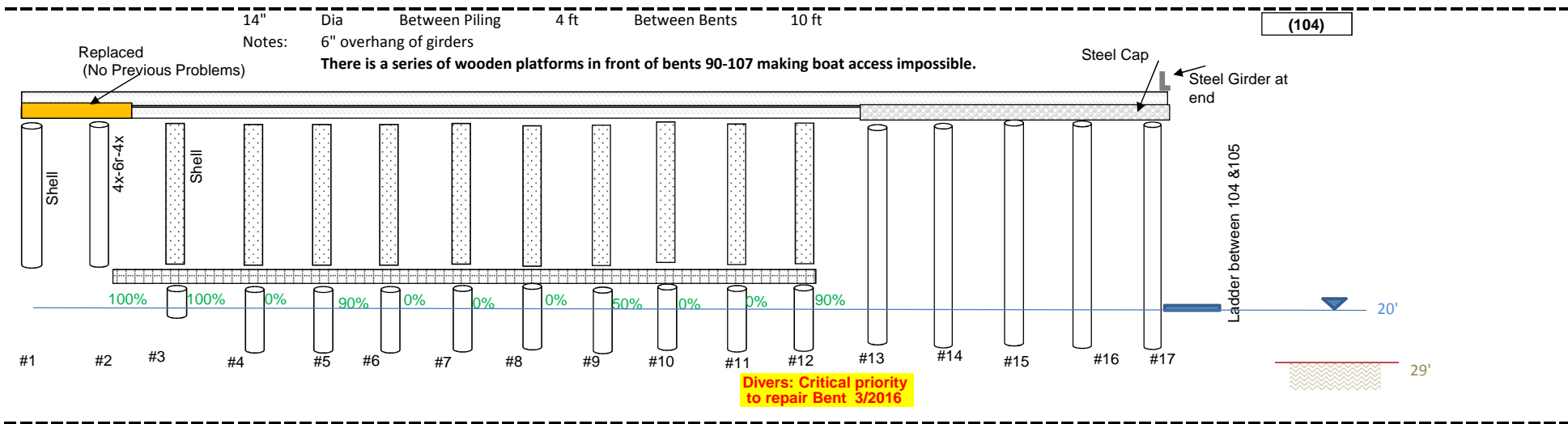
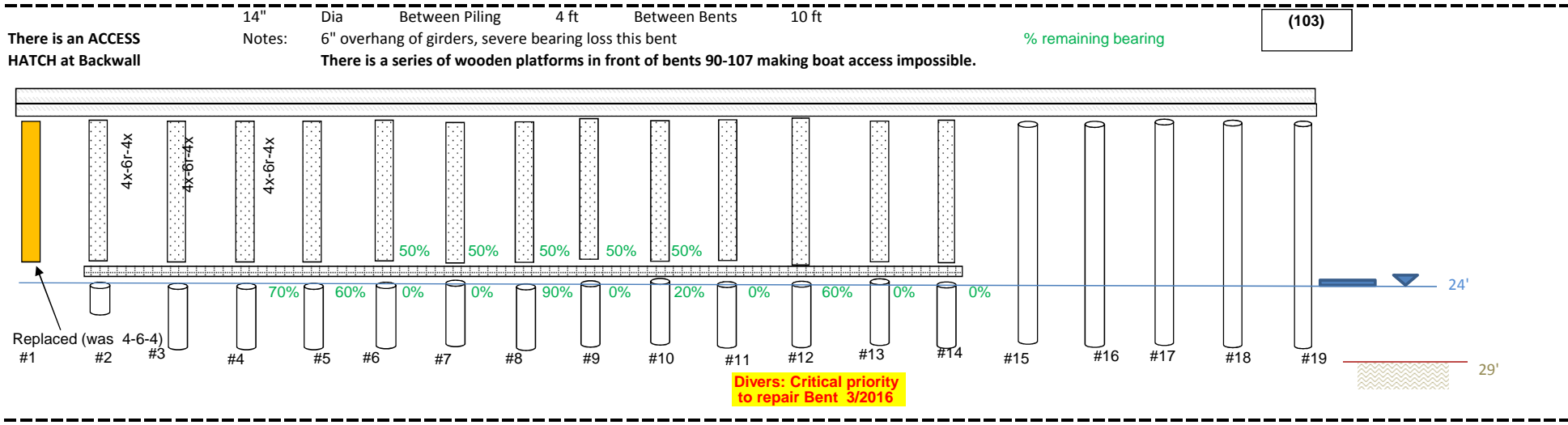

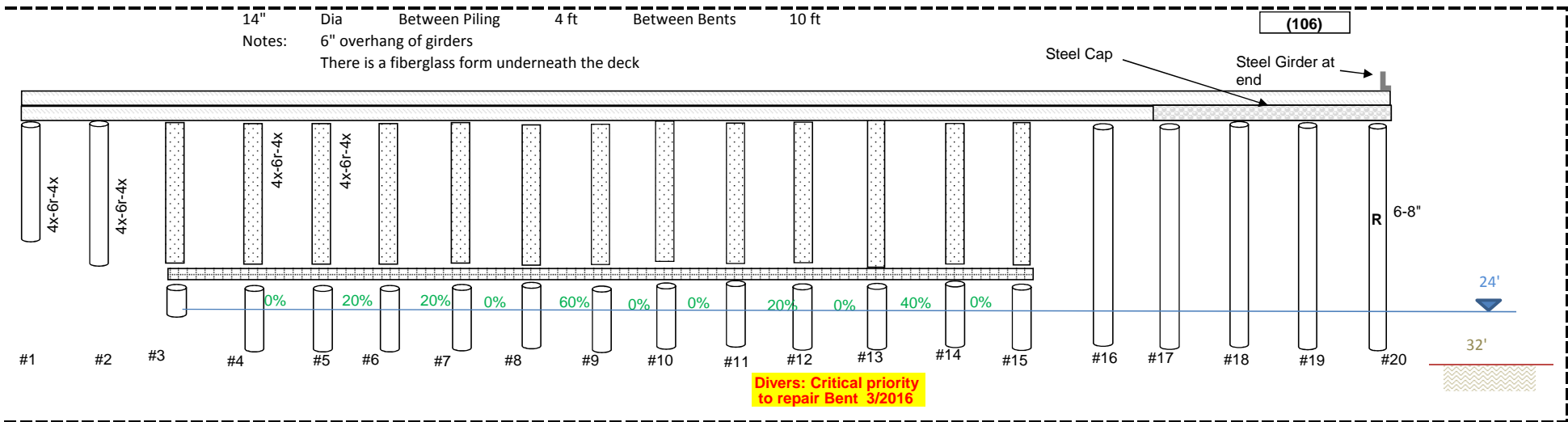
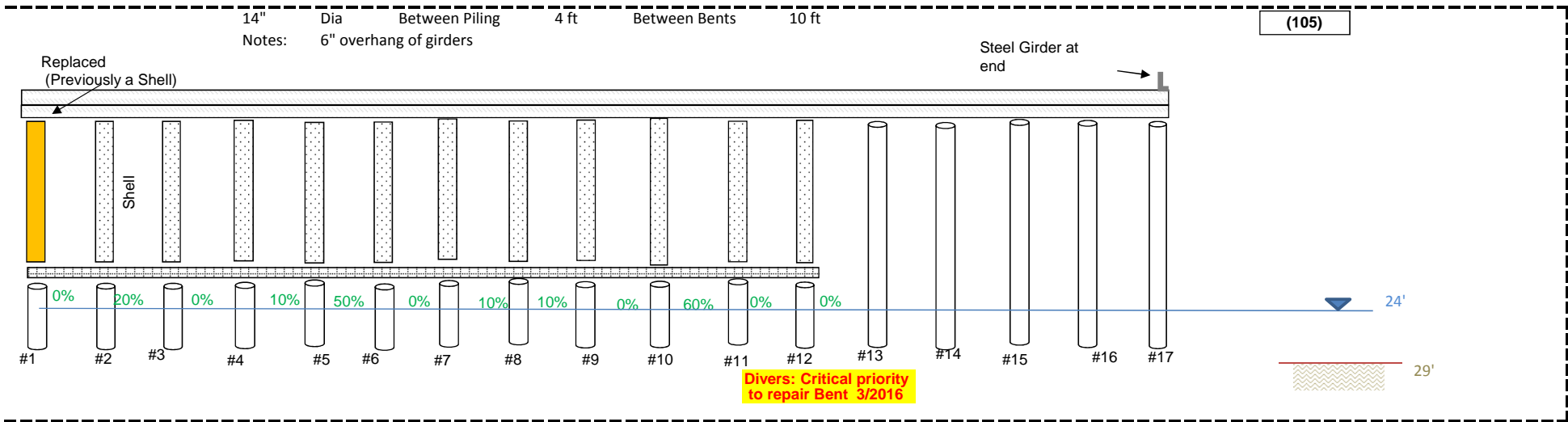

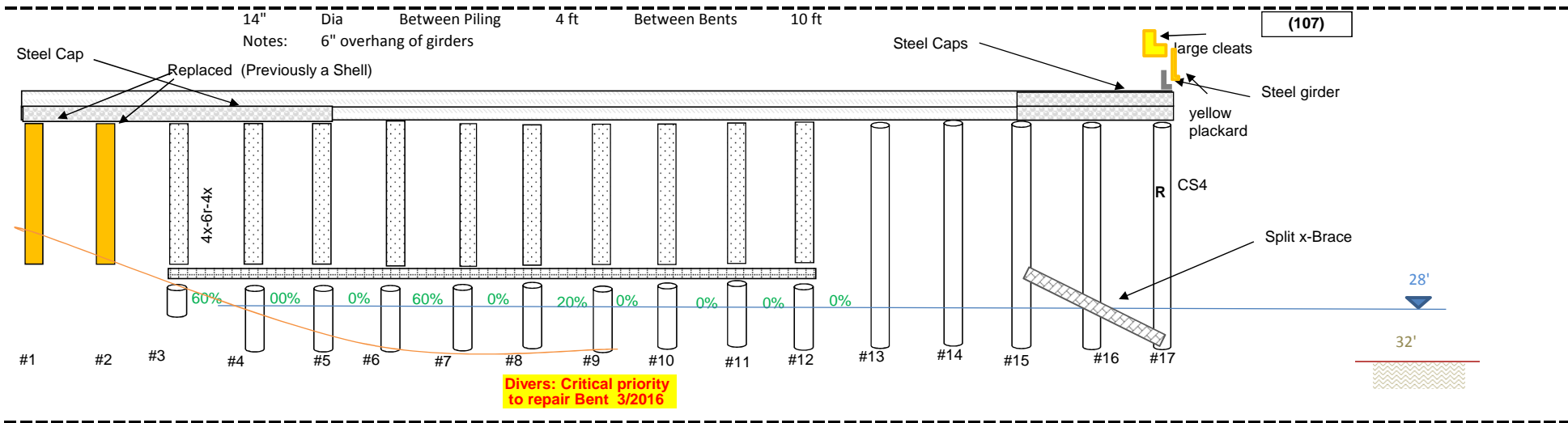

Port of Astoria Pier 2
 Results of Inspection 9/2015 & 1/2016
 BRIDGE 22452

S
 Shimmed

Cross Bracing & Girders generally not pictured
 3-4 girders per pile. Girders are 13.5" x 6"
 Caps are 14" x 14"

Blue Bearing Loss
 Red Section Loss
 Unless otherwise noted, piles & columns - CS1, caps & girders - CS2

#22452 3/4

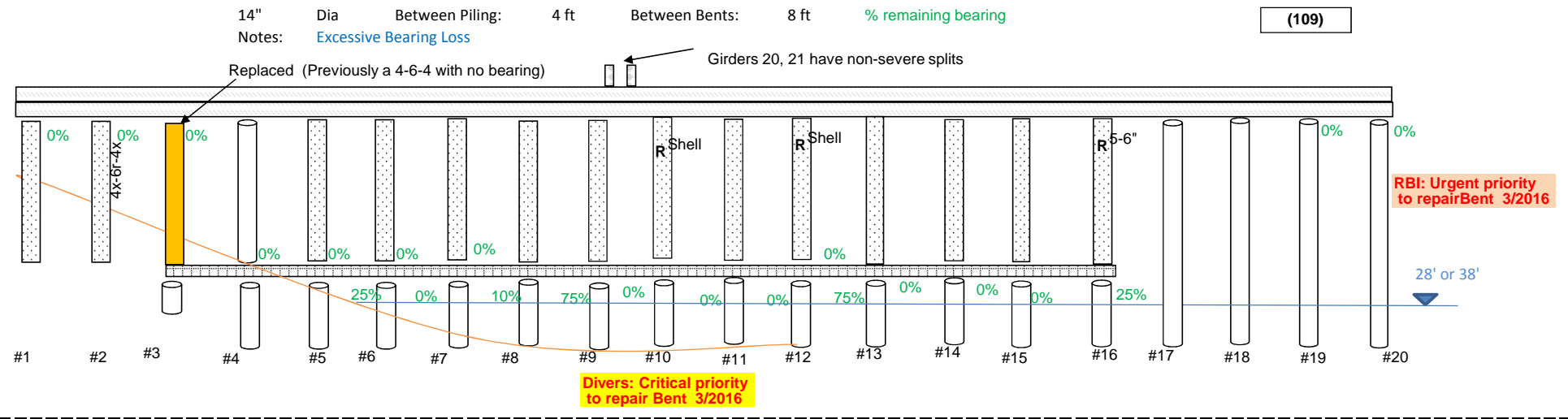
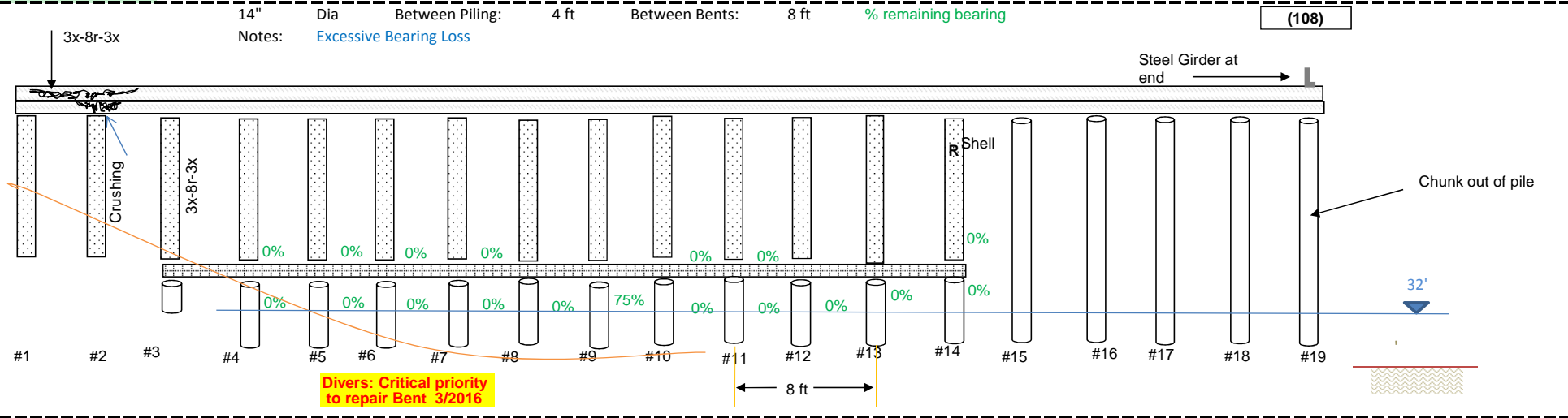

RBI: Urgent priority to repair Bent 3/2016

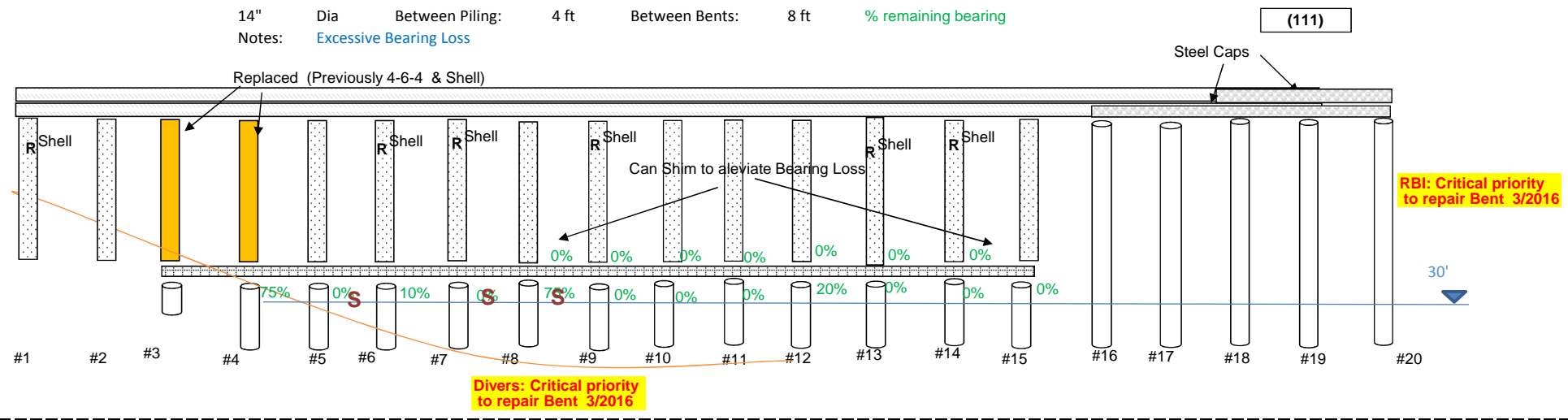
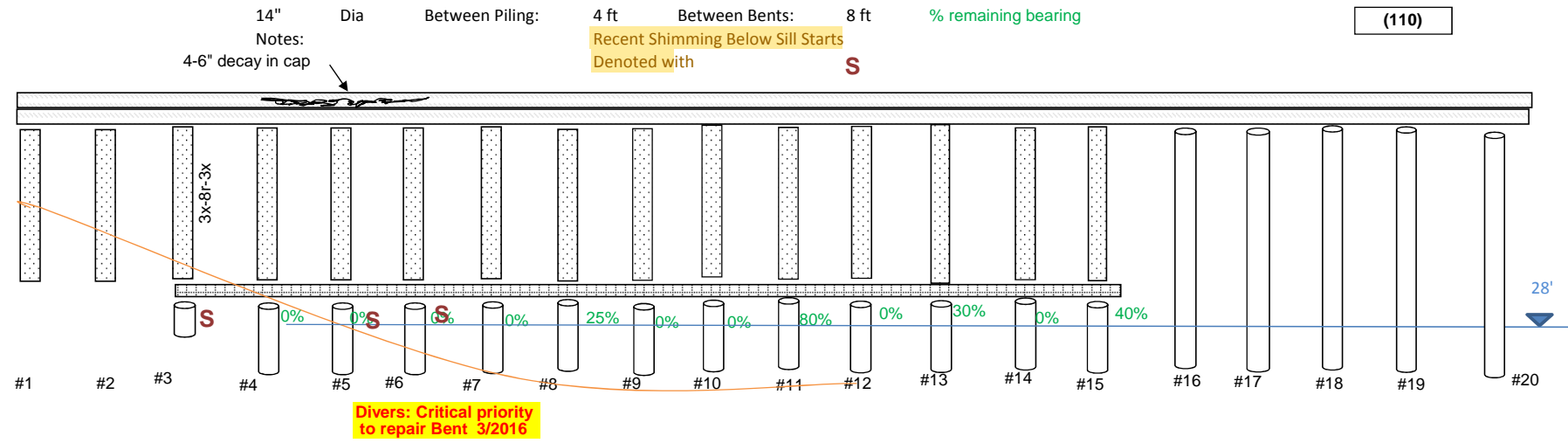

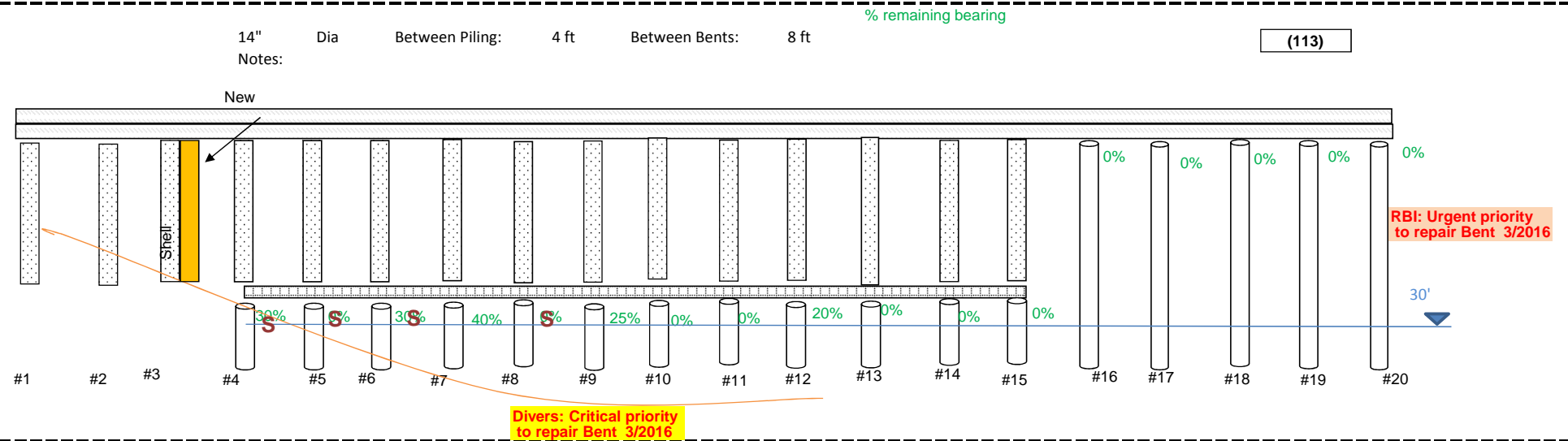
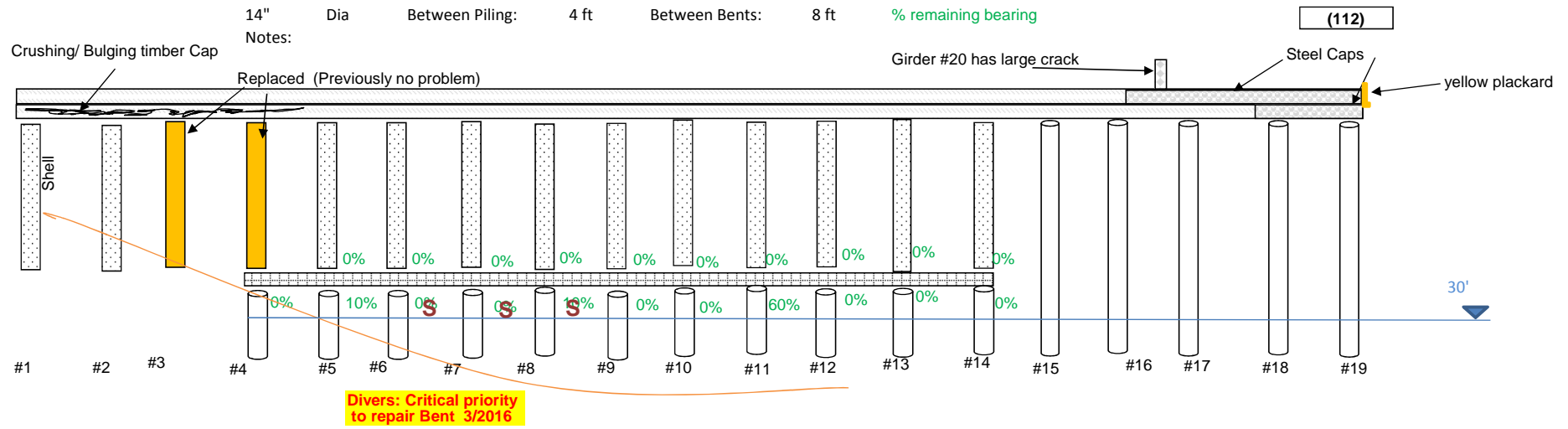

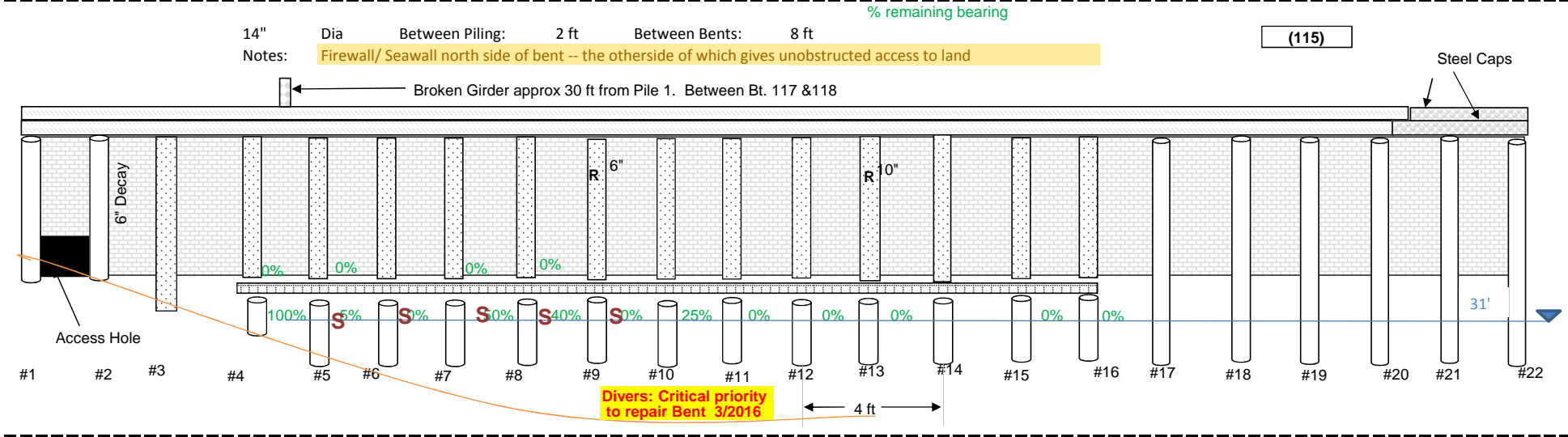
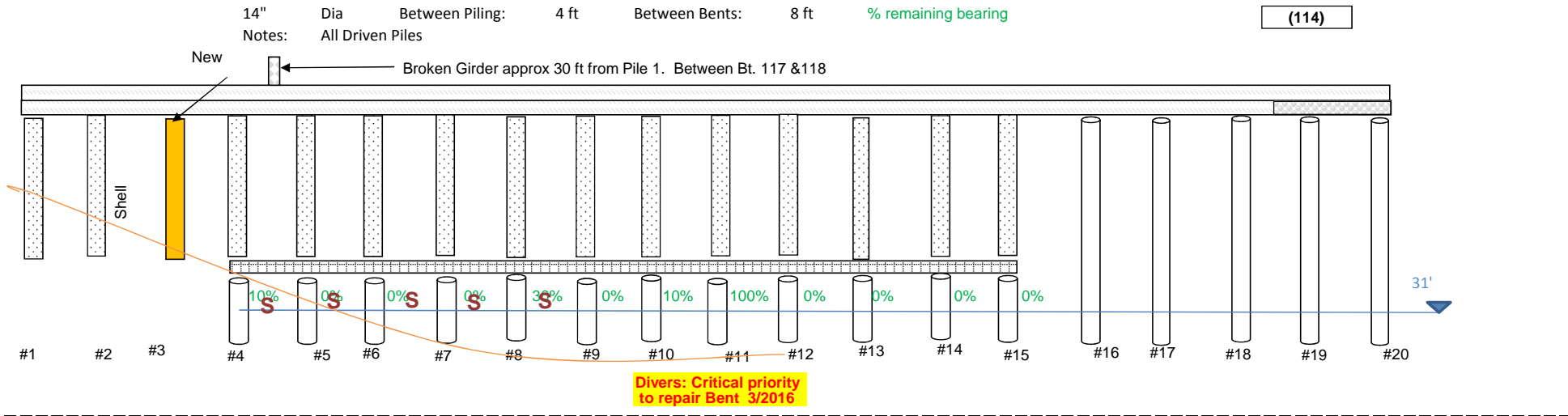

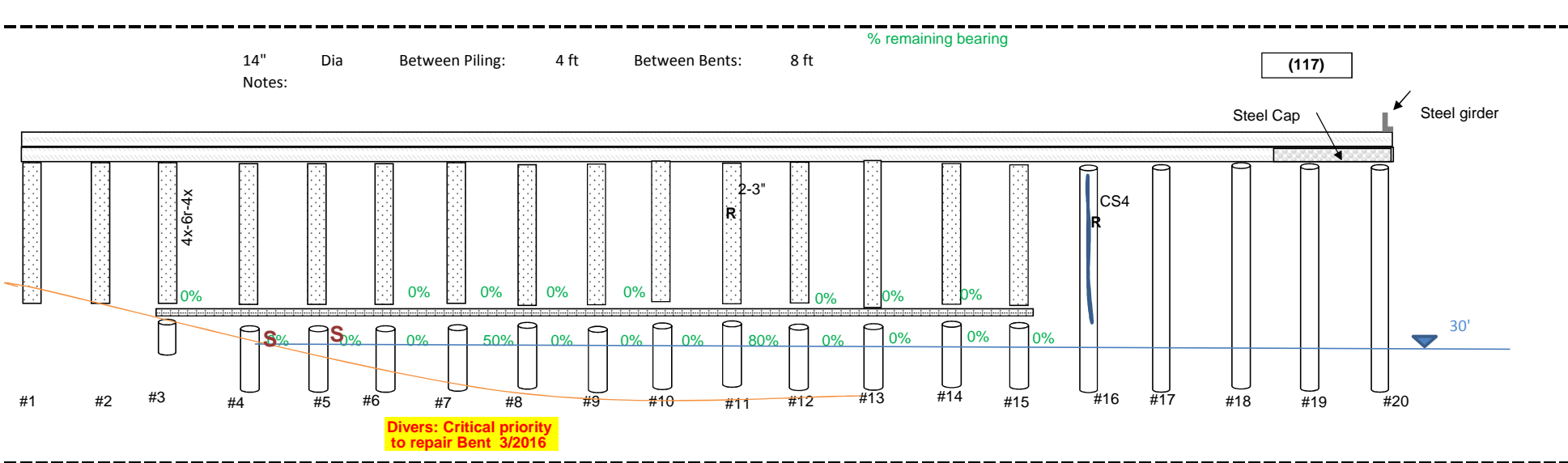
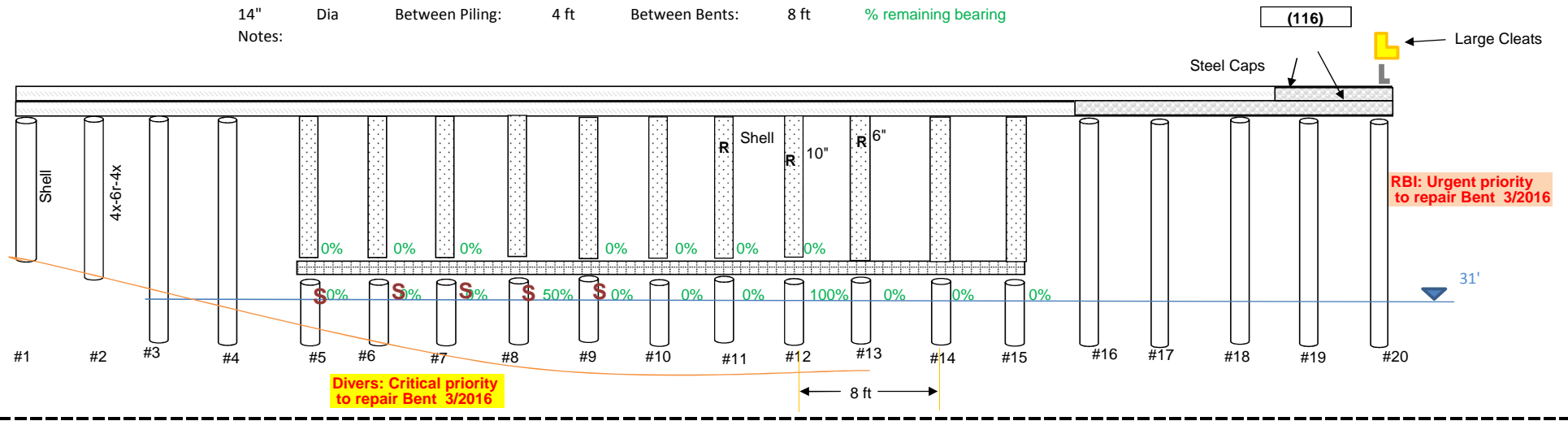

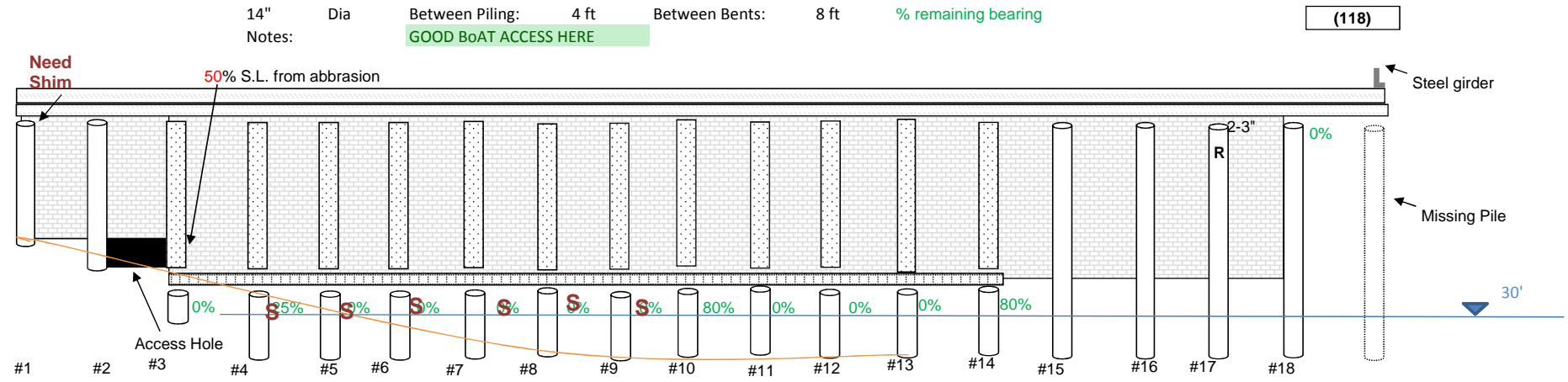

Divers: Critical priority to repair Bent 3/2016

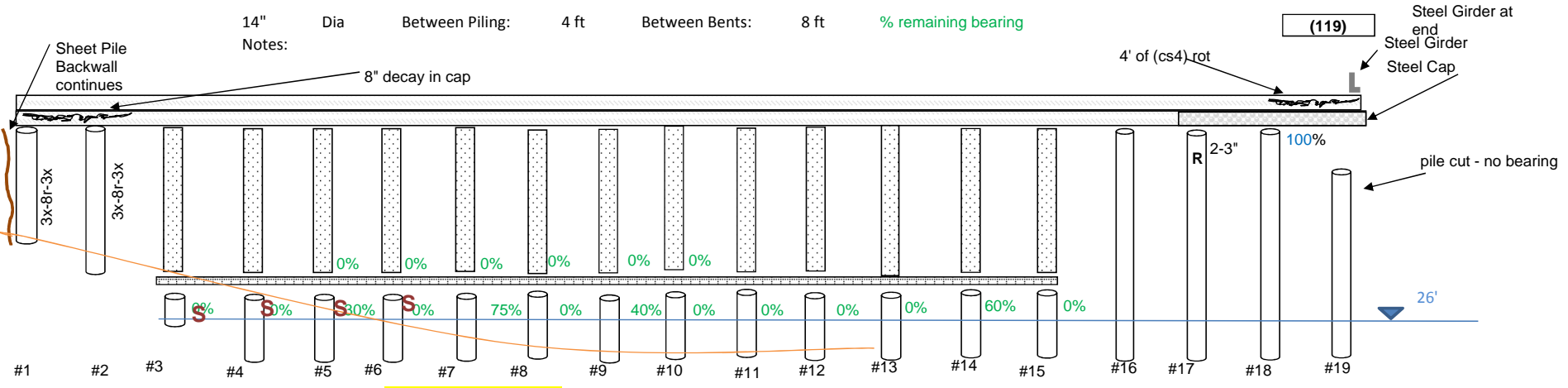

Divers: Critical priority to repair Bent 3/2016

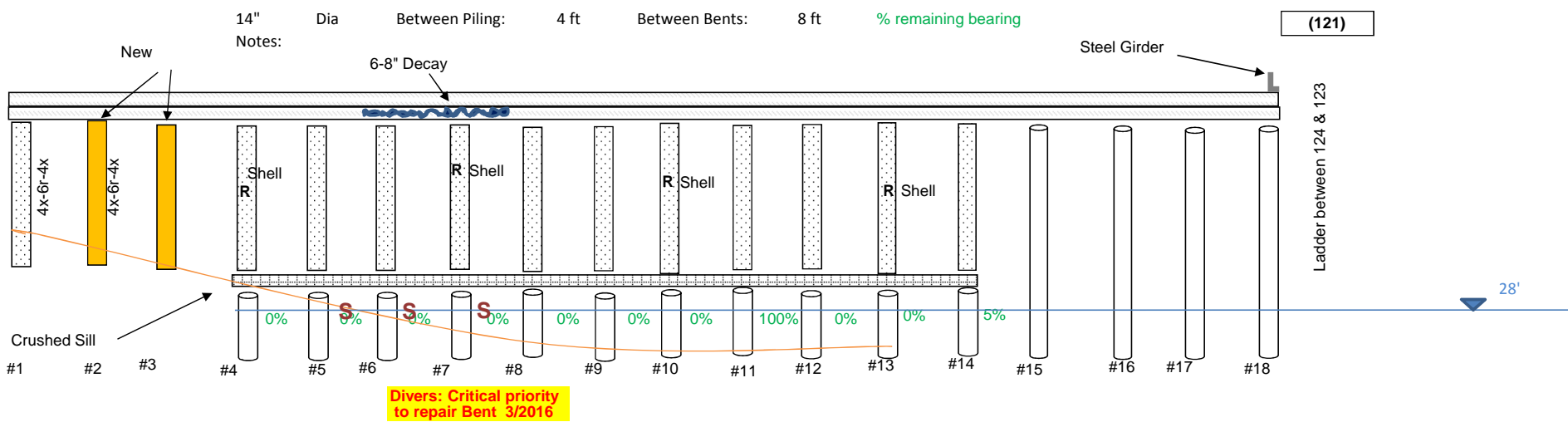
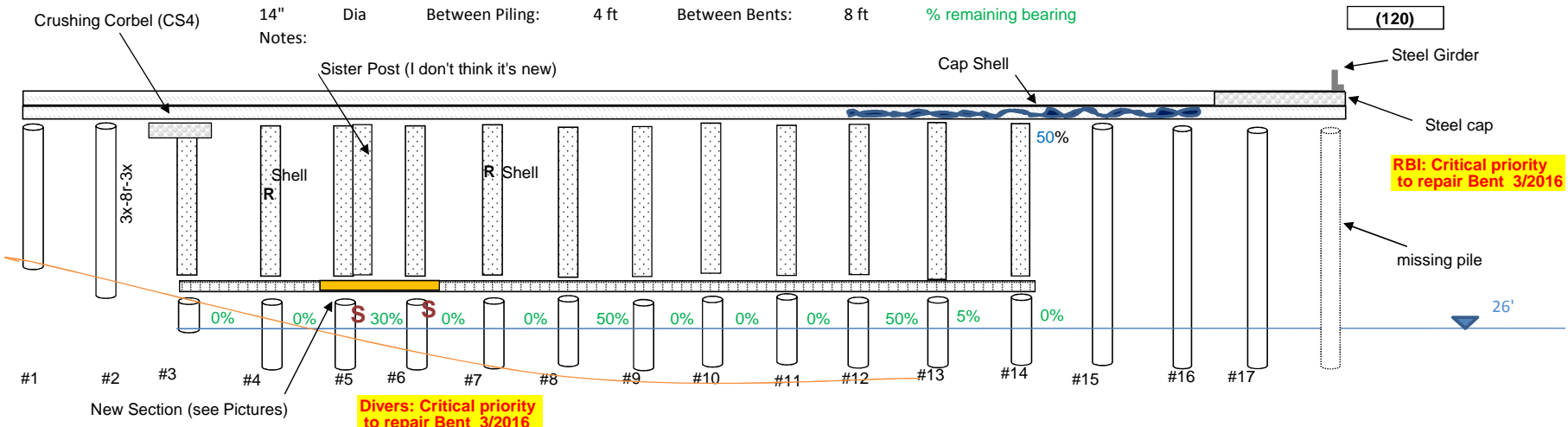

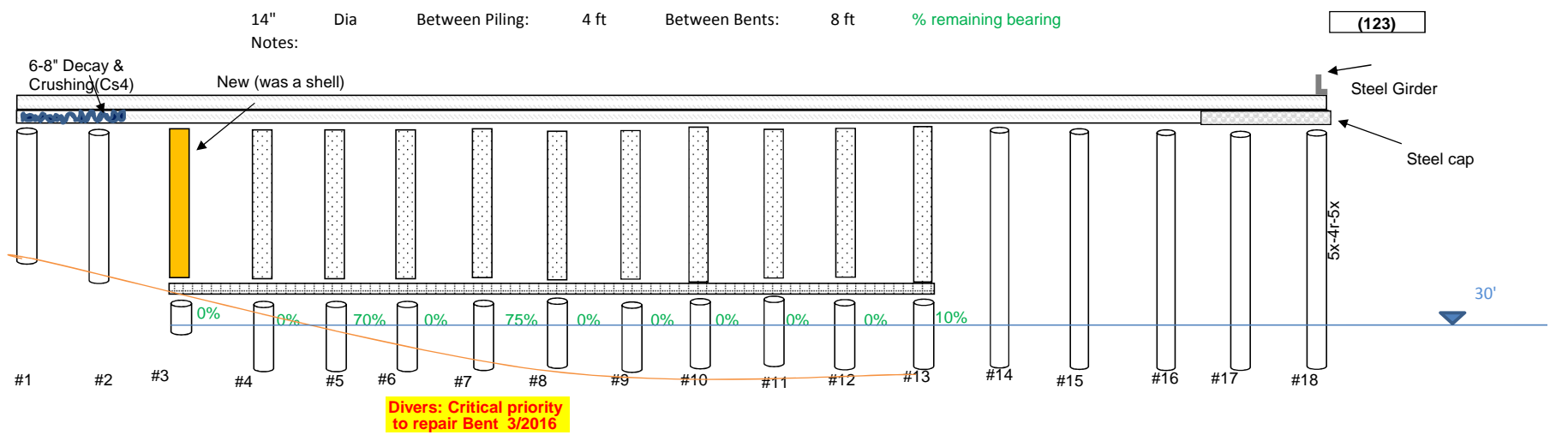
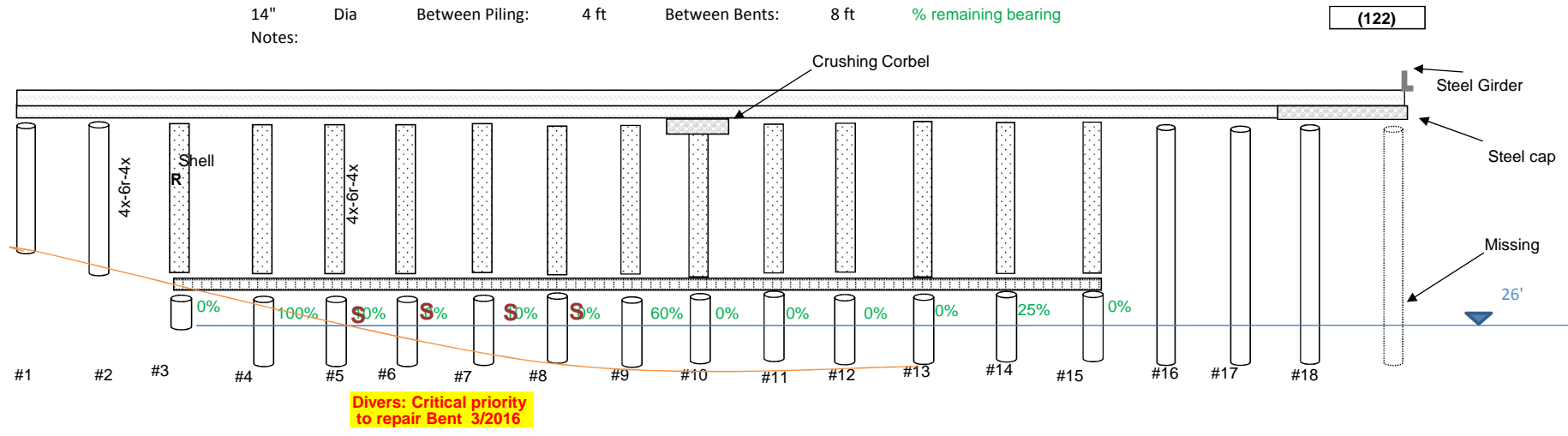

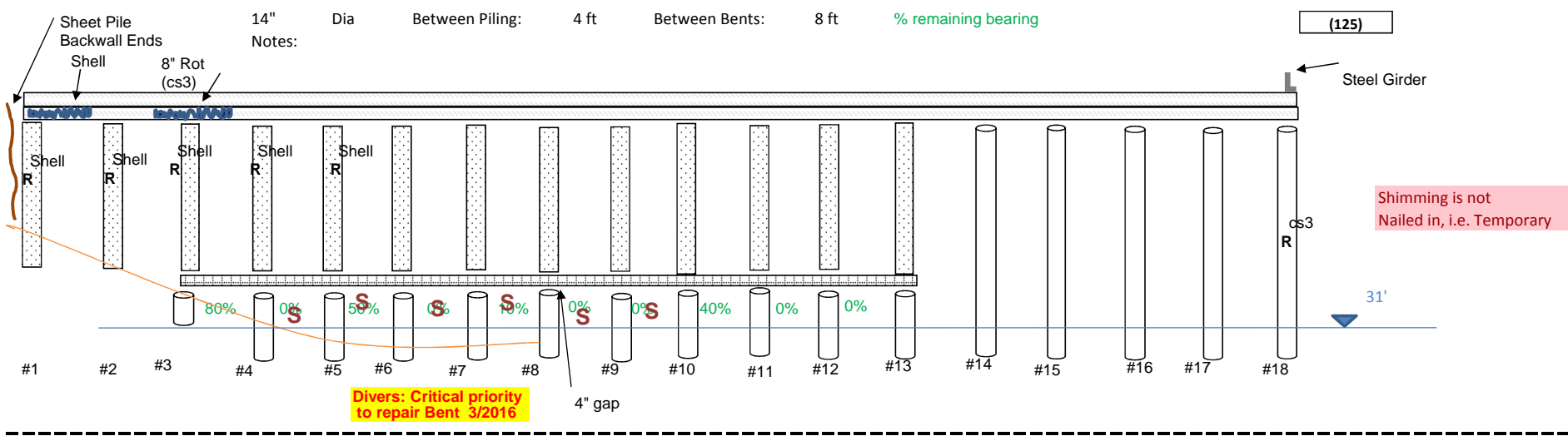
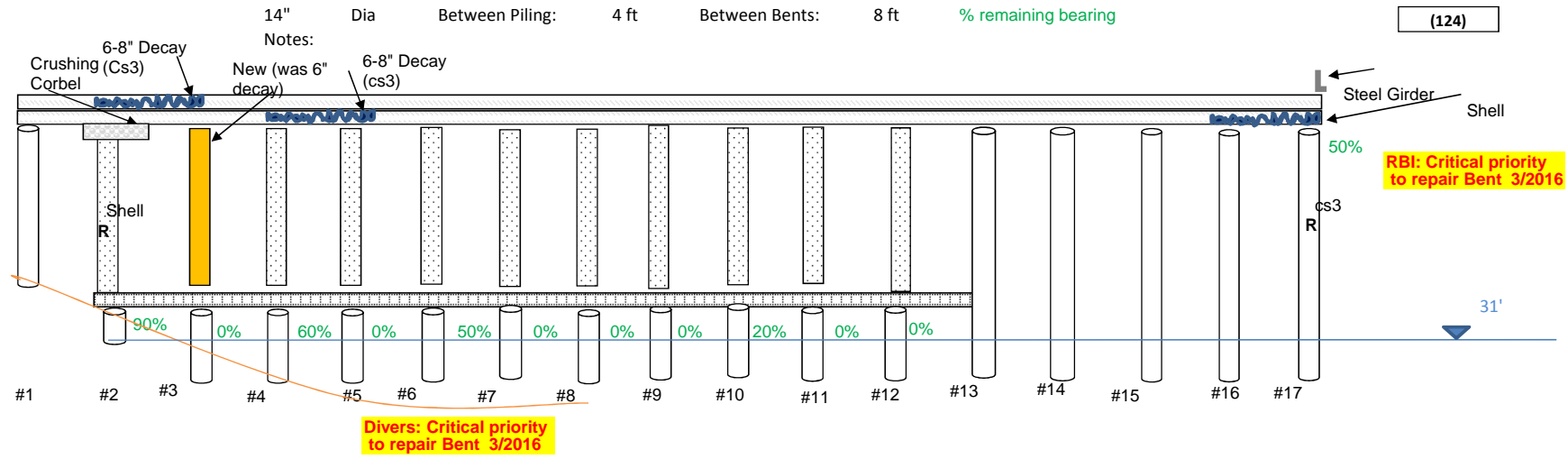

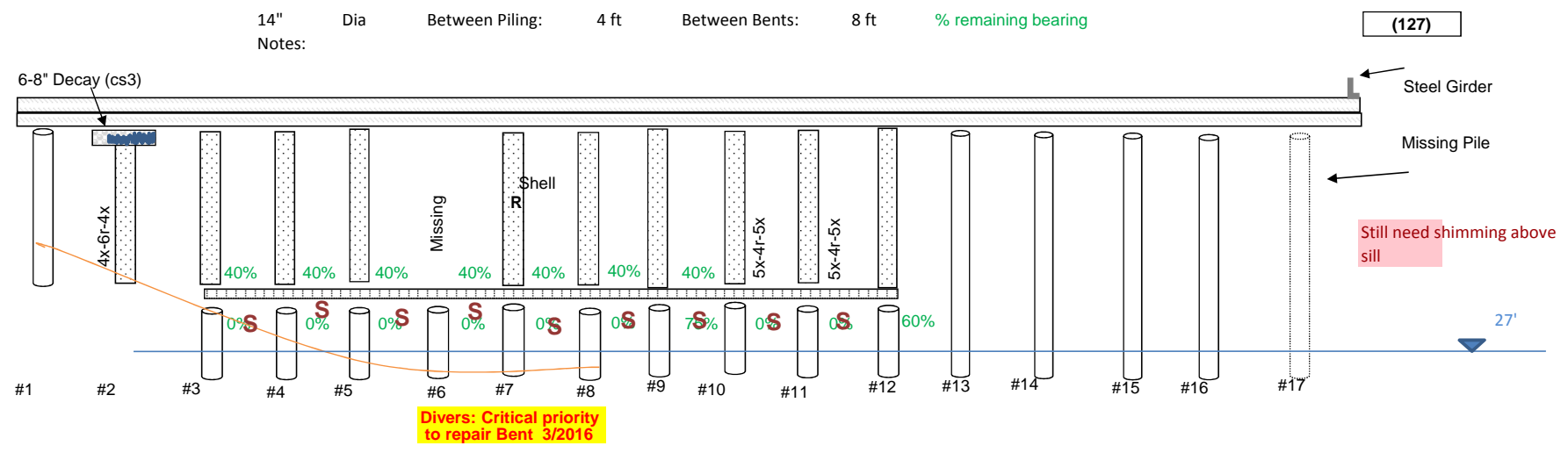
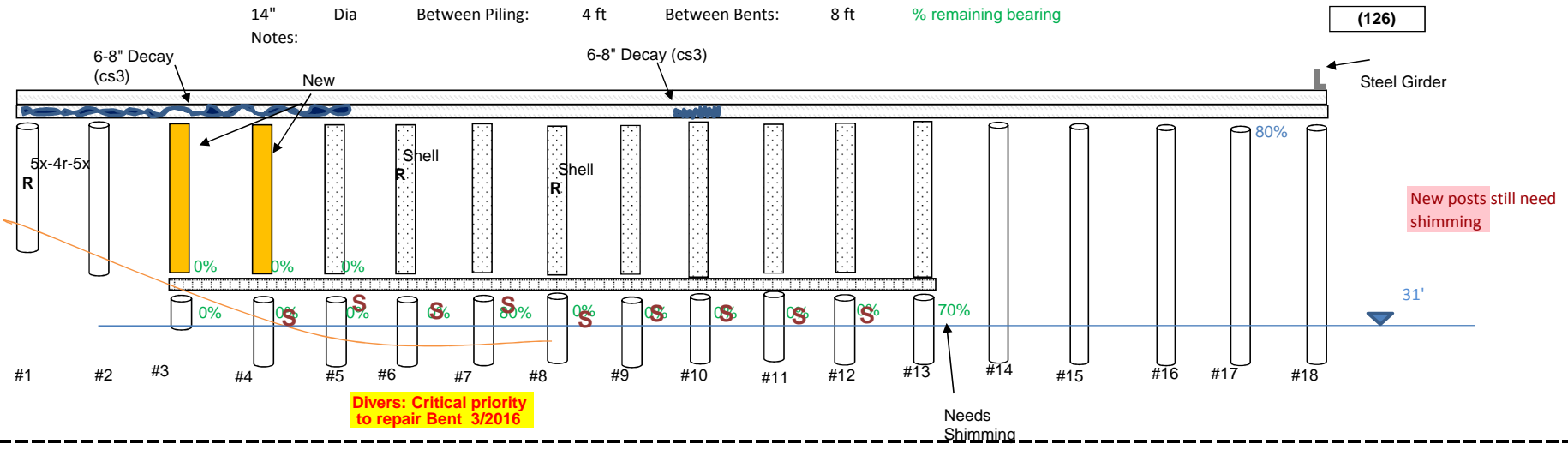

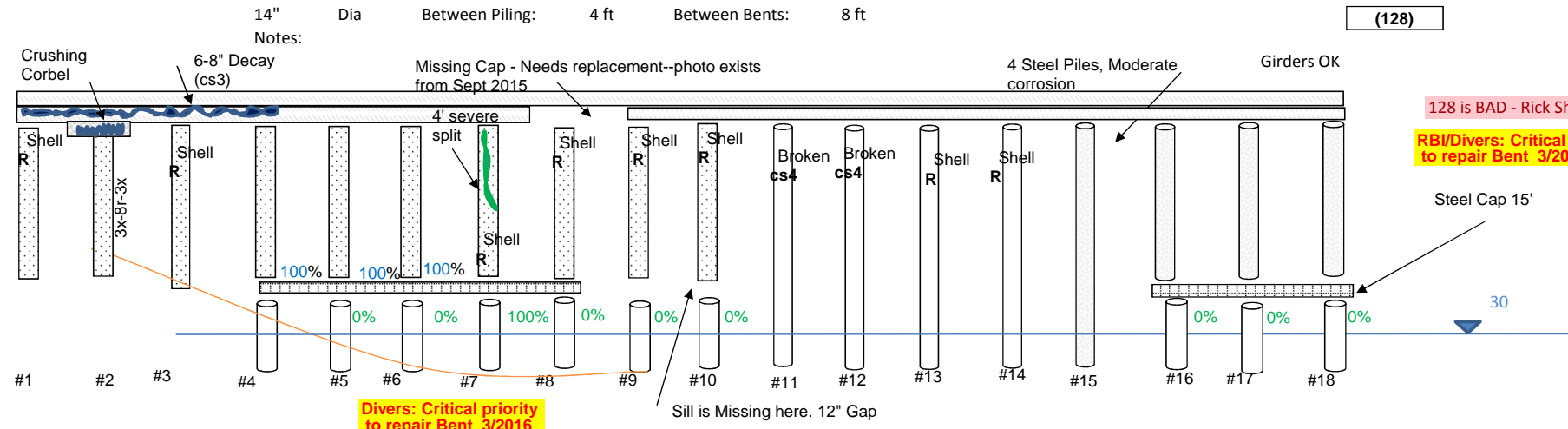

128 is BAD - Rick Shorb

RBI/Divers: Critical priority to repair Bent 3/2016

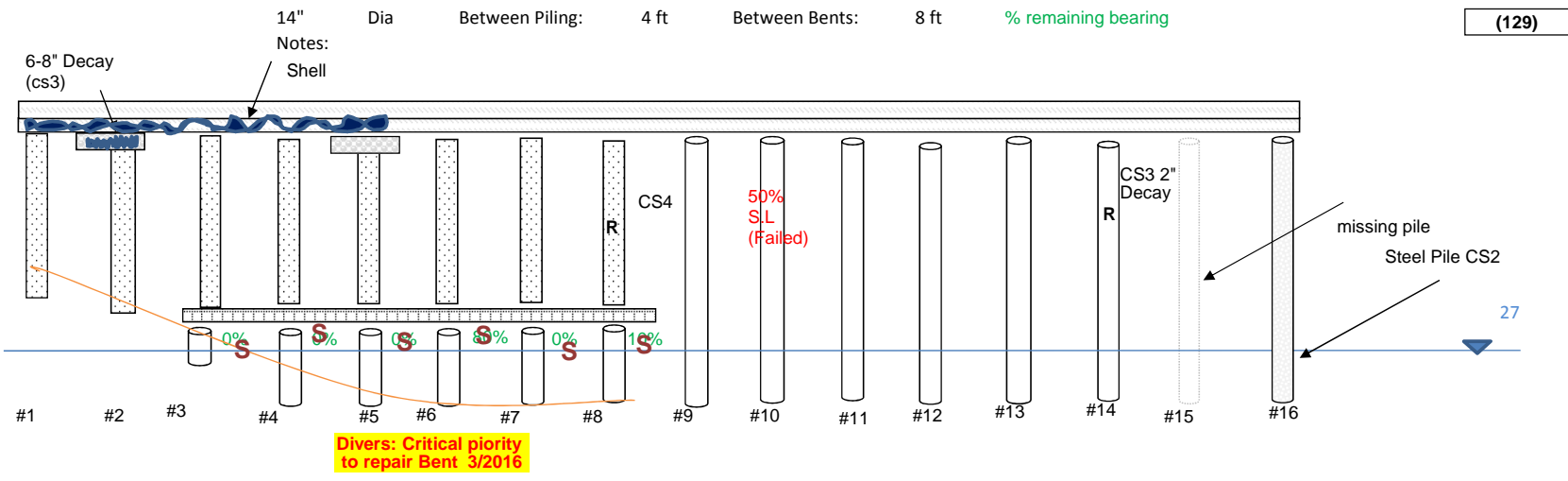

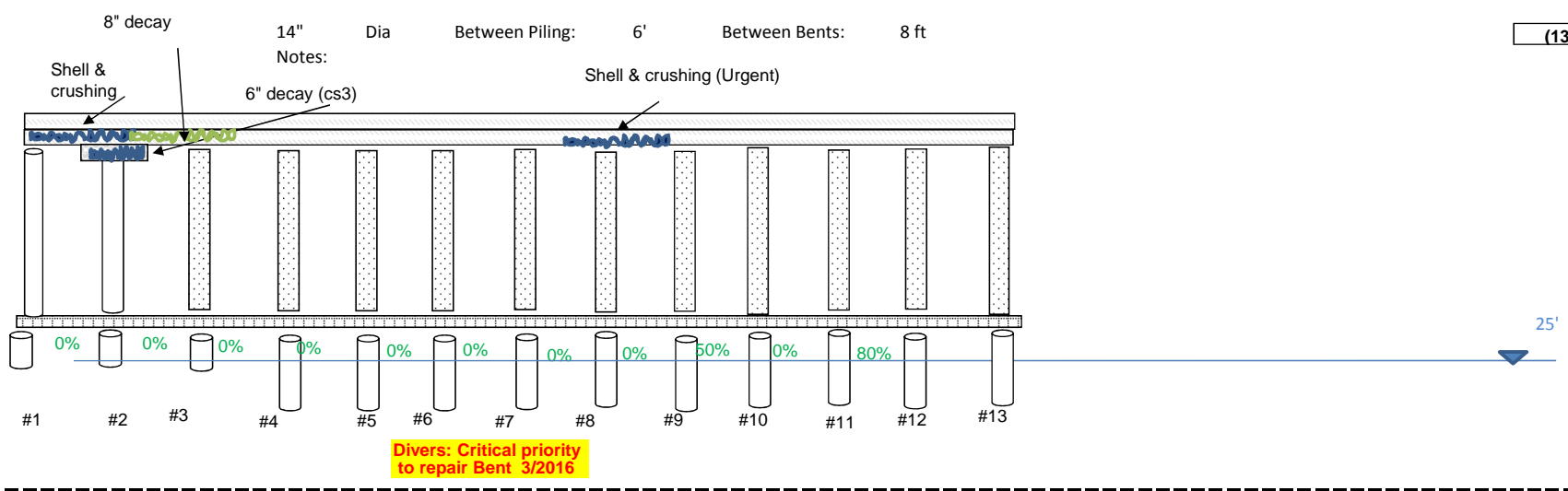
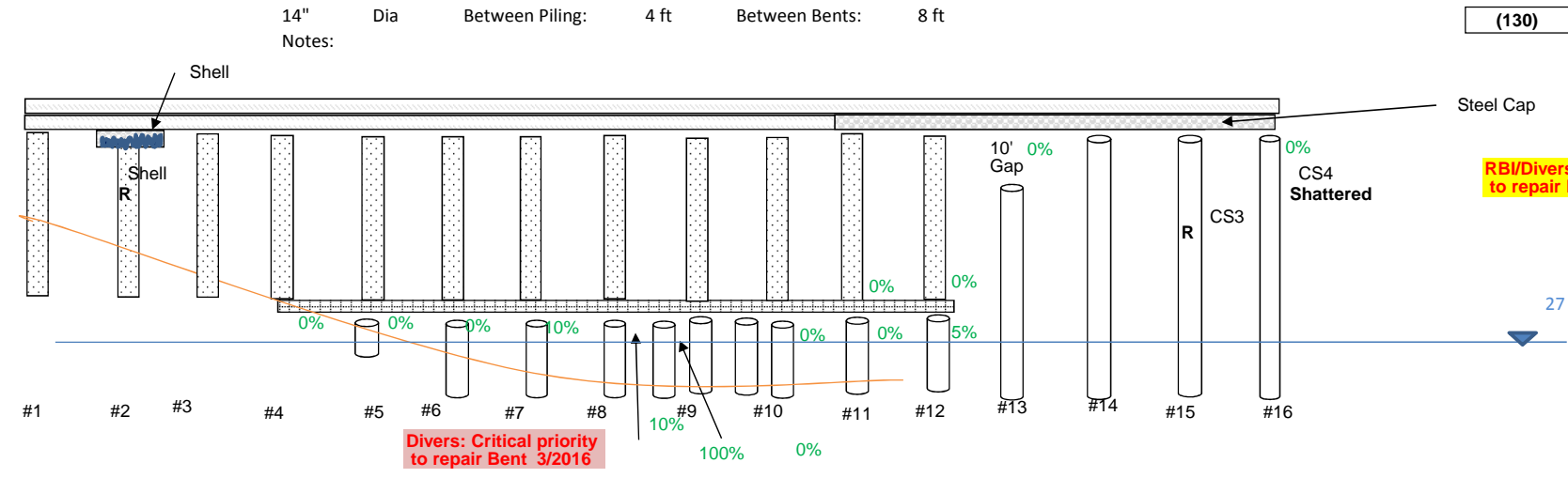

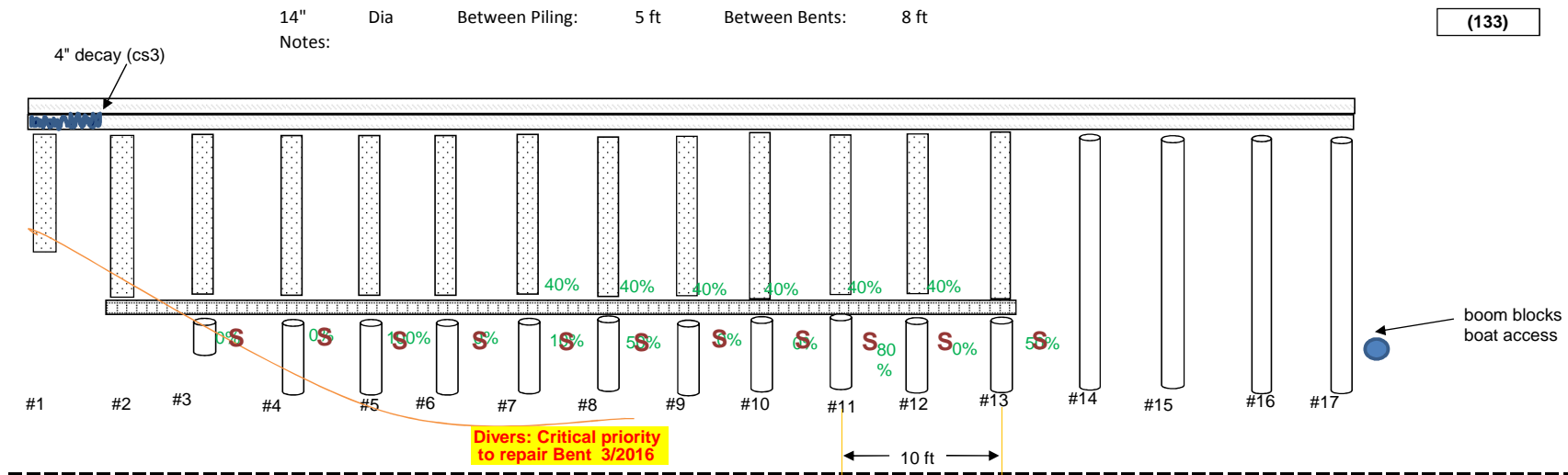
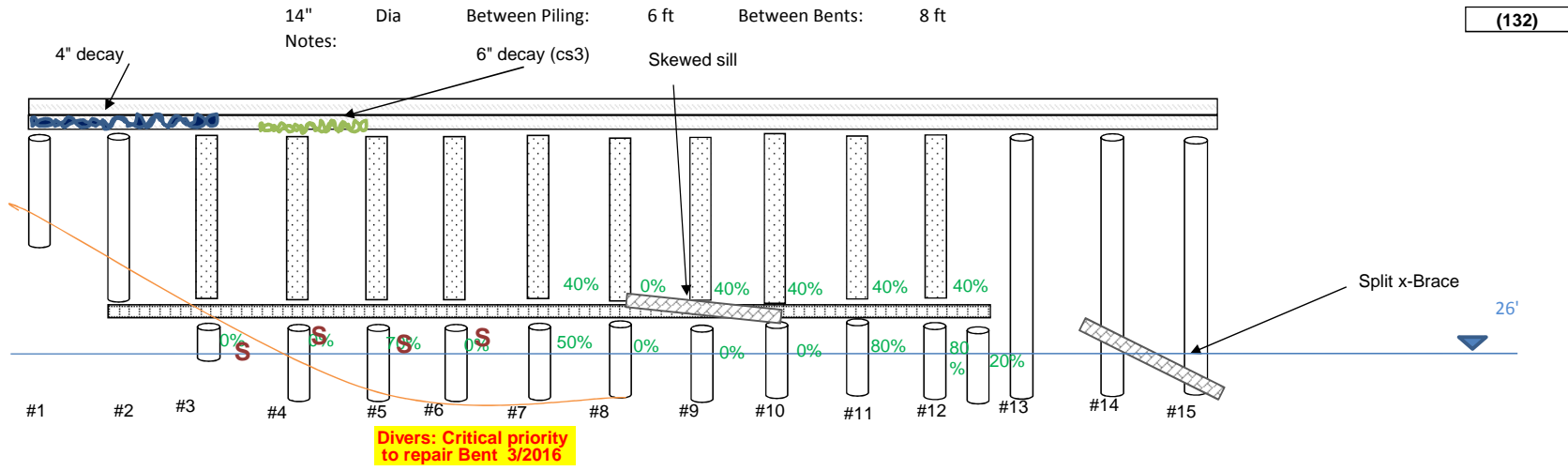

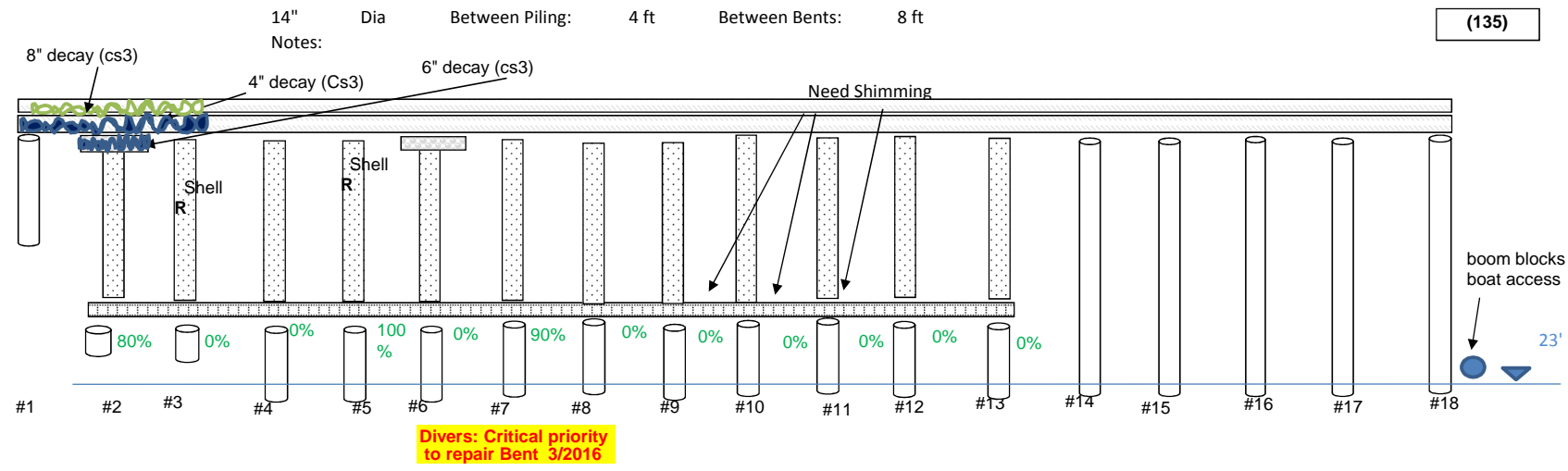
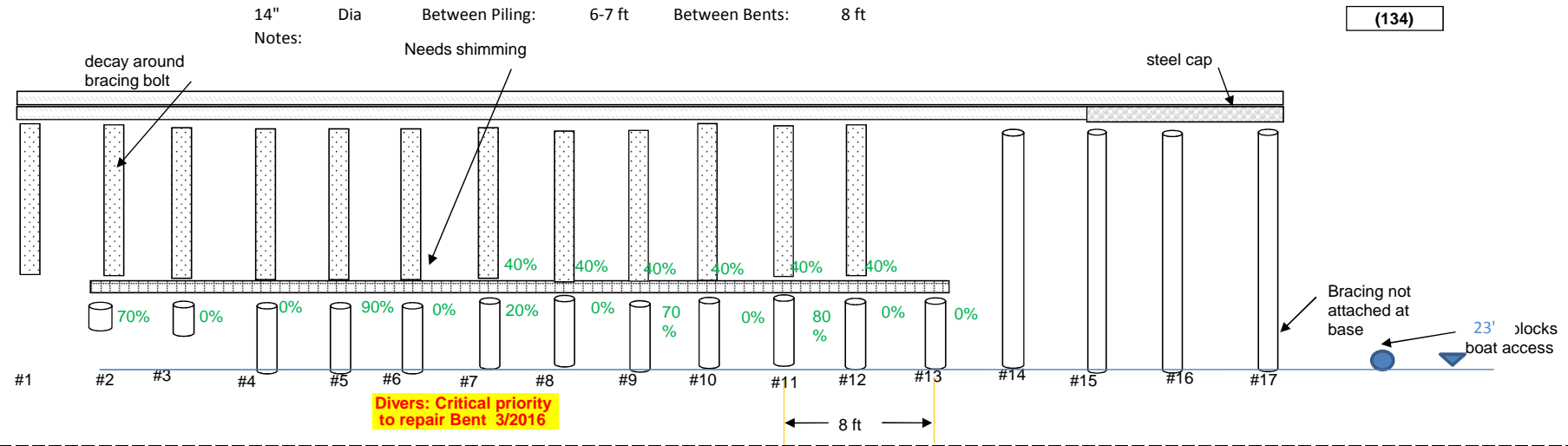

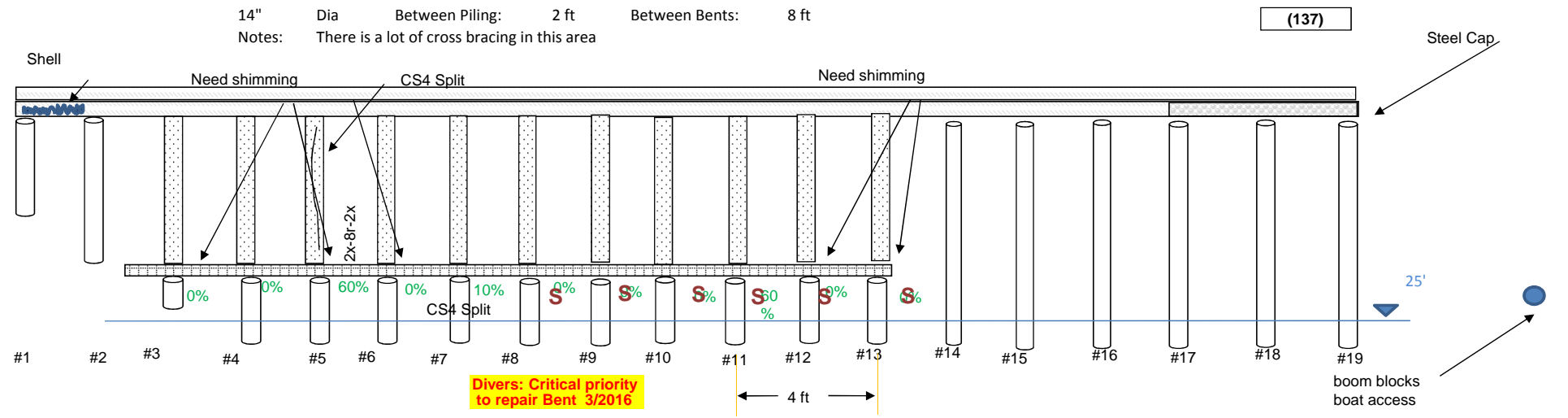
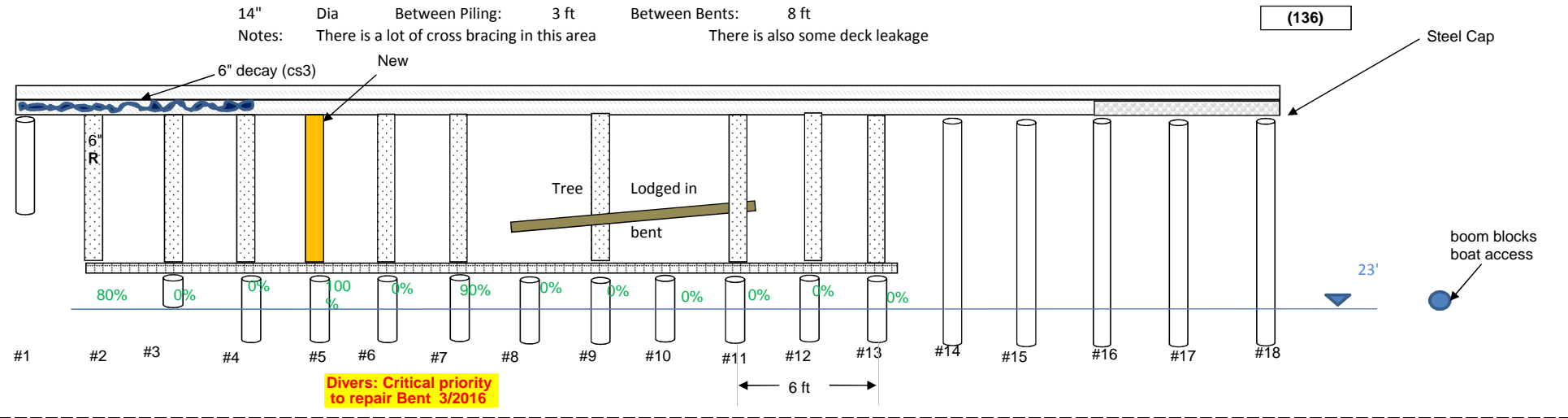

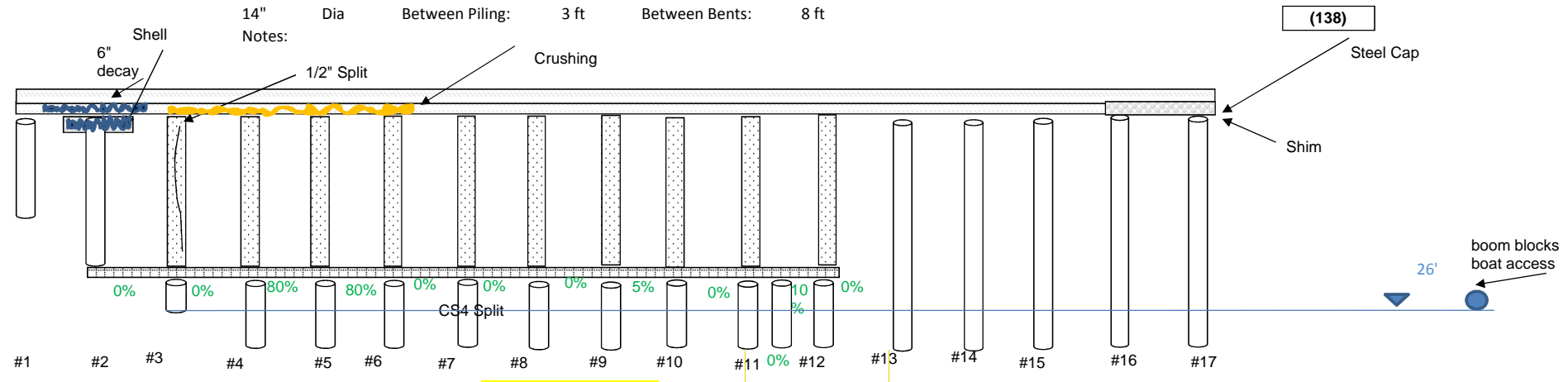

Divers: Critical priority to repair Bent 3/2016

6 ft

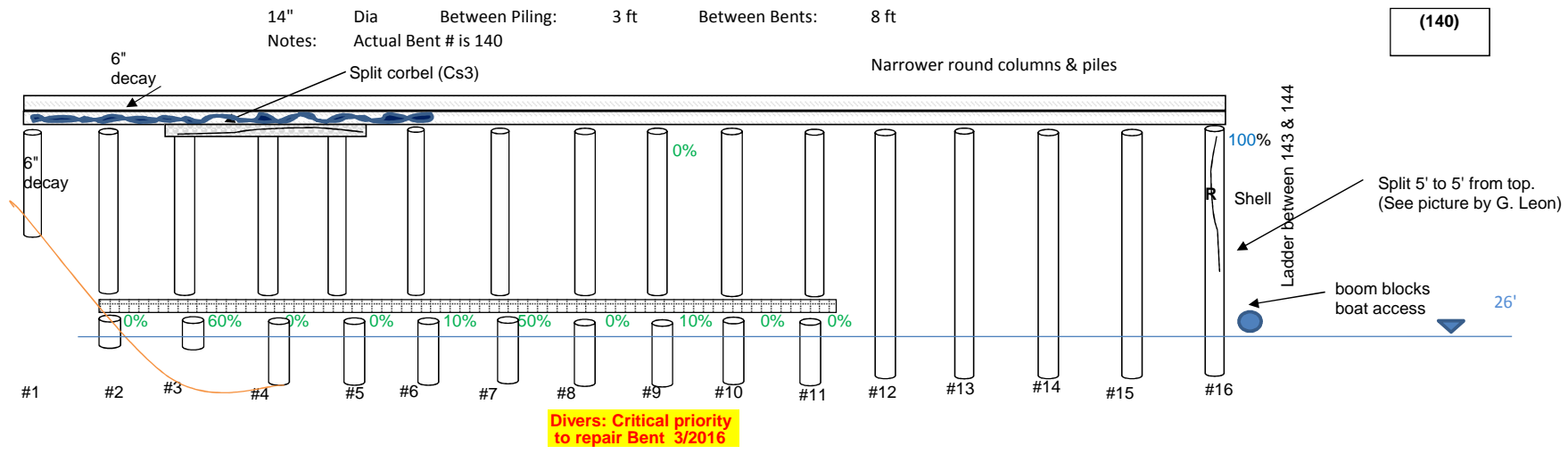
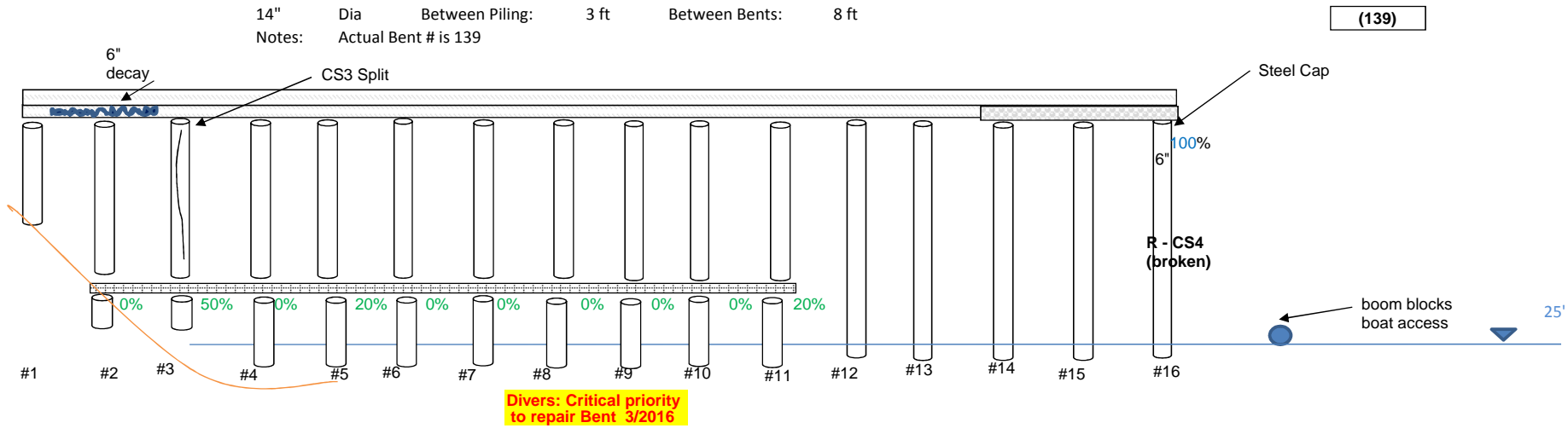

14" Dia Between Piling: 5 ft Between Bents: 8 ft
Notes:

(141)

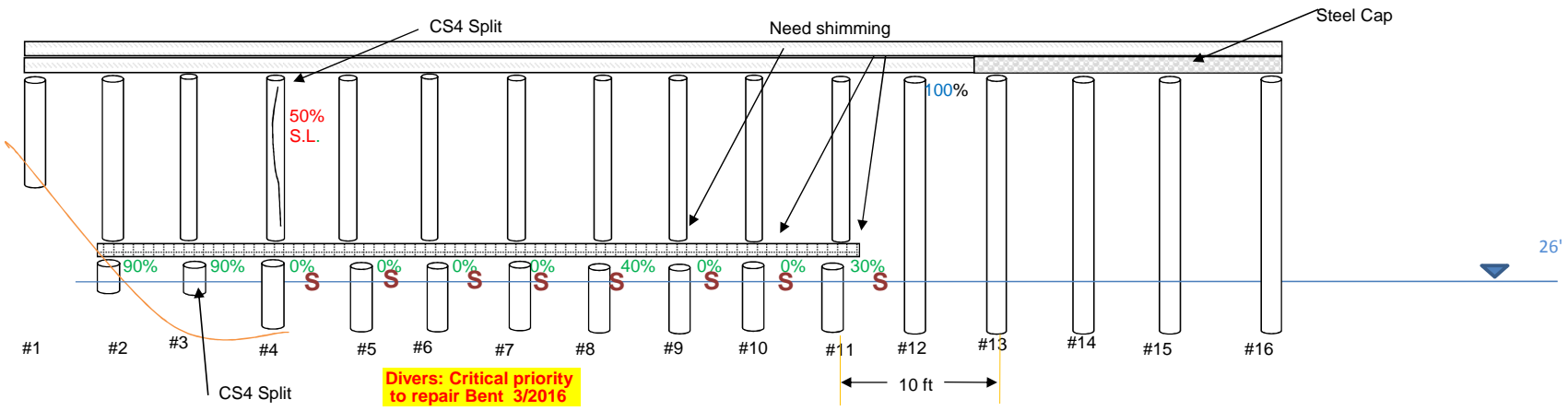

14" Dia Between Piling: 5 ft Between Bents: 8 ft
Notes:

(142)

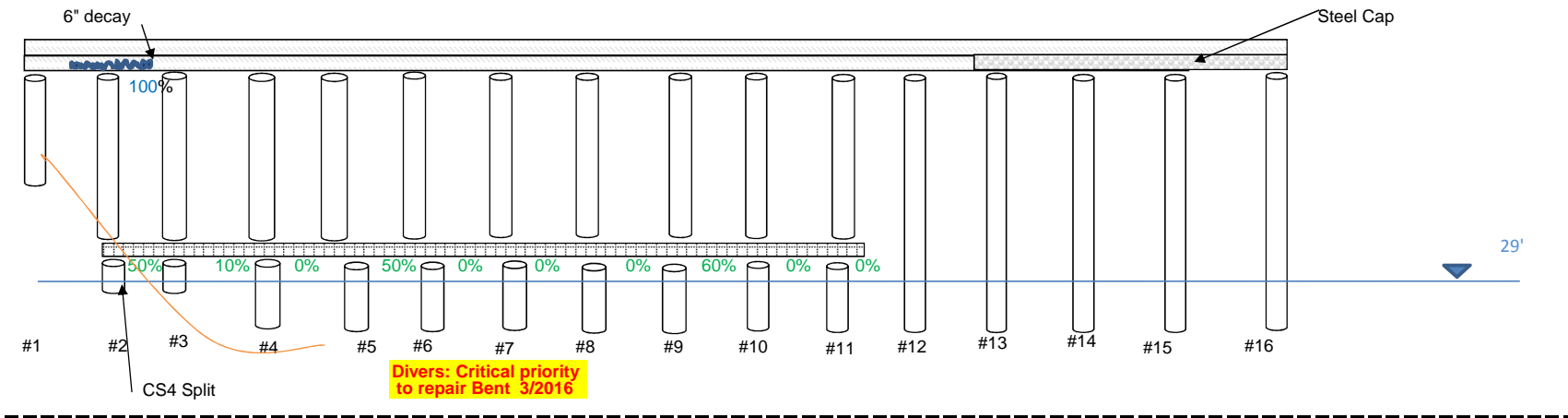

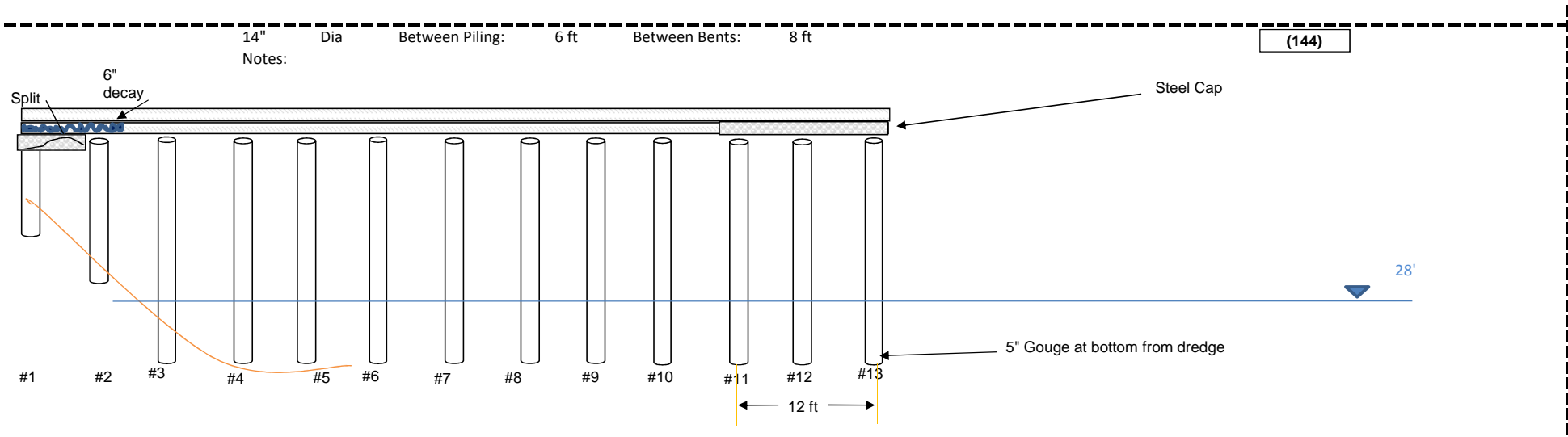
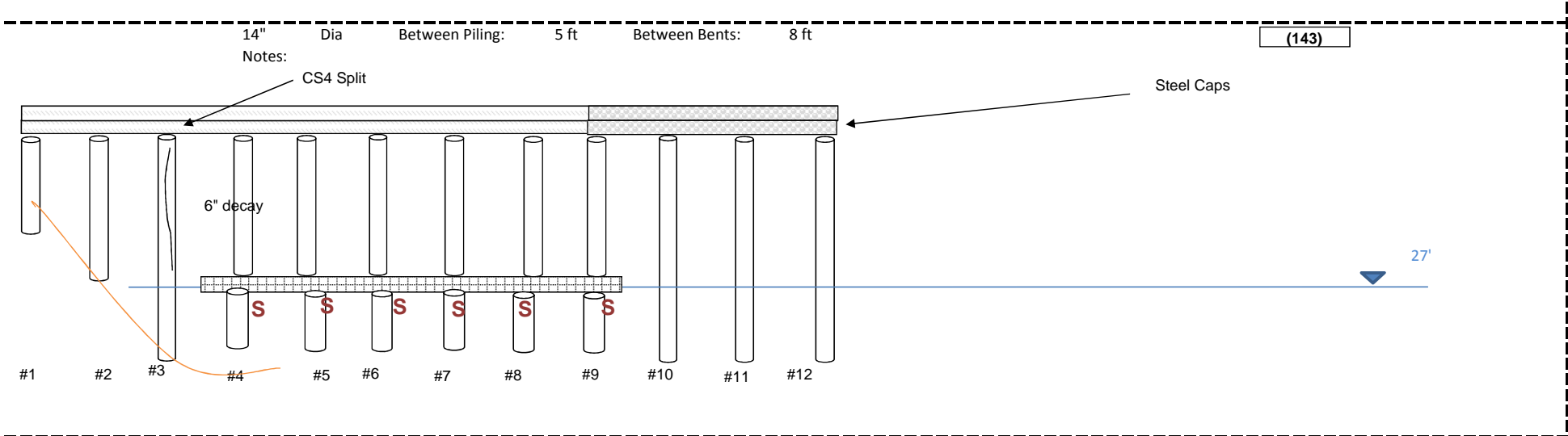

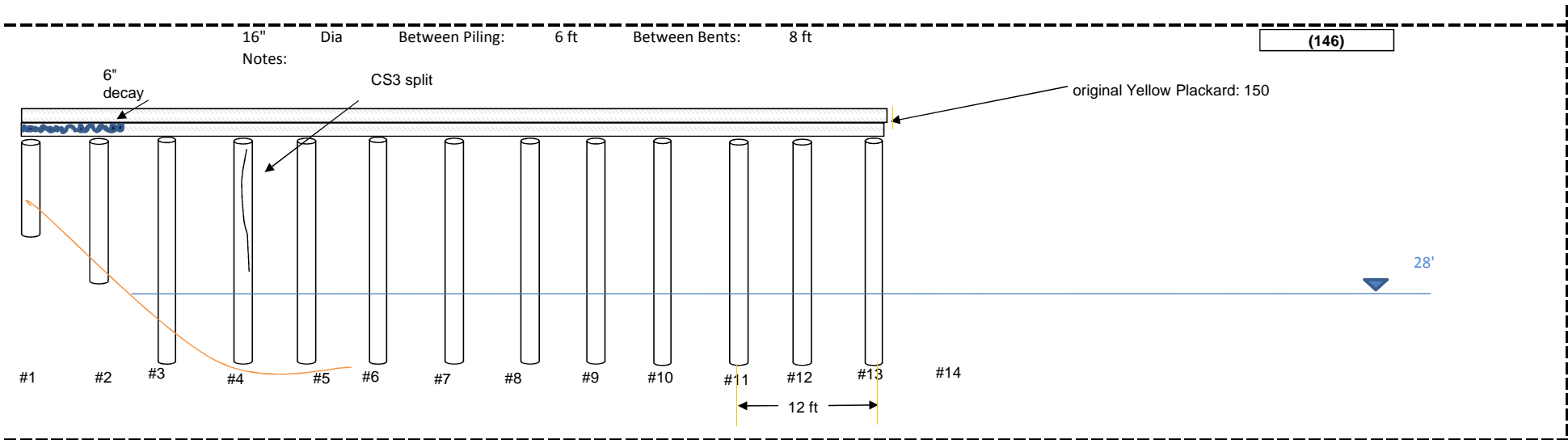
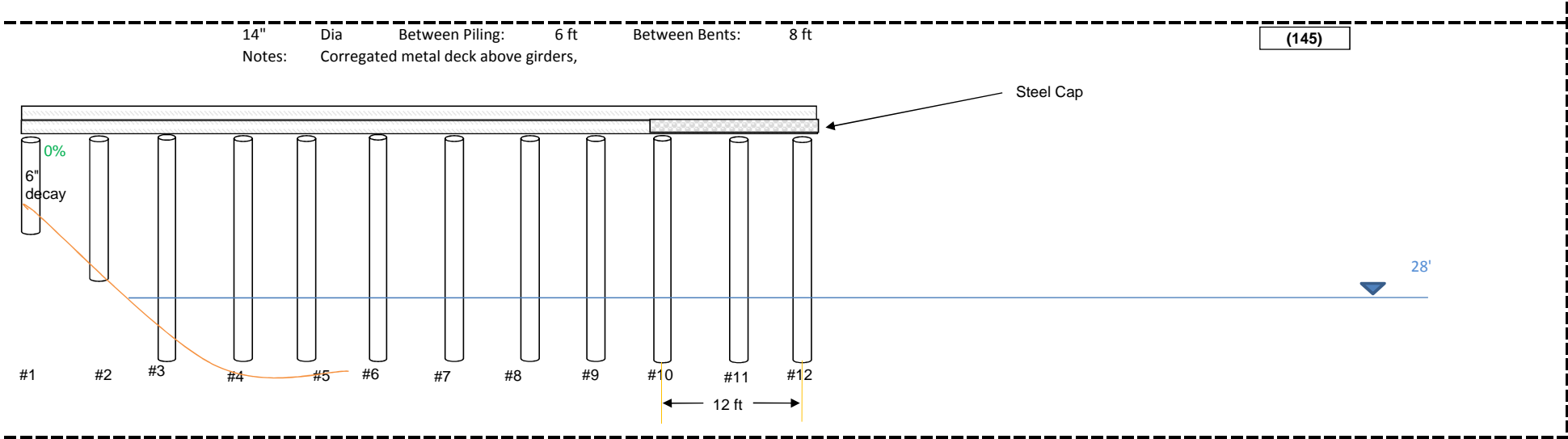

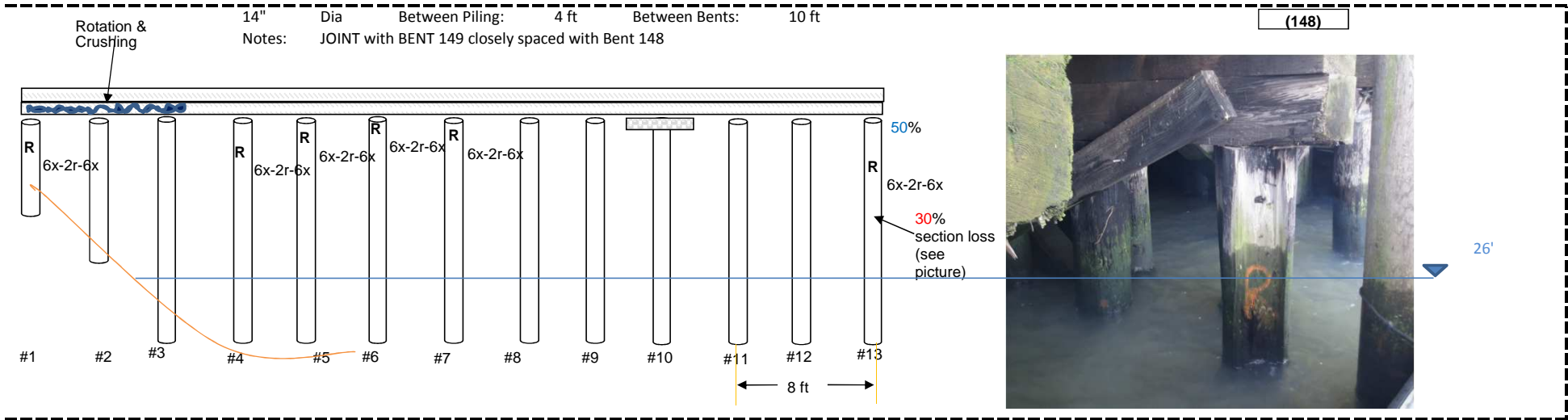
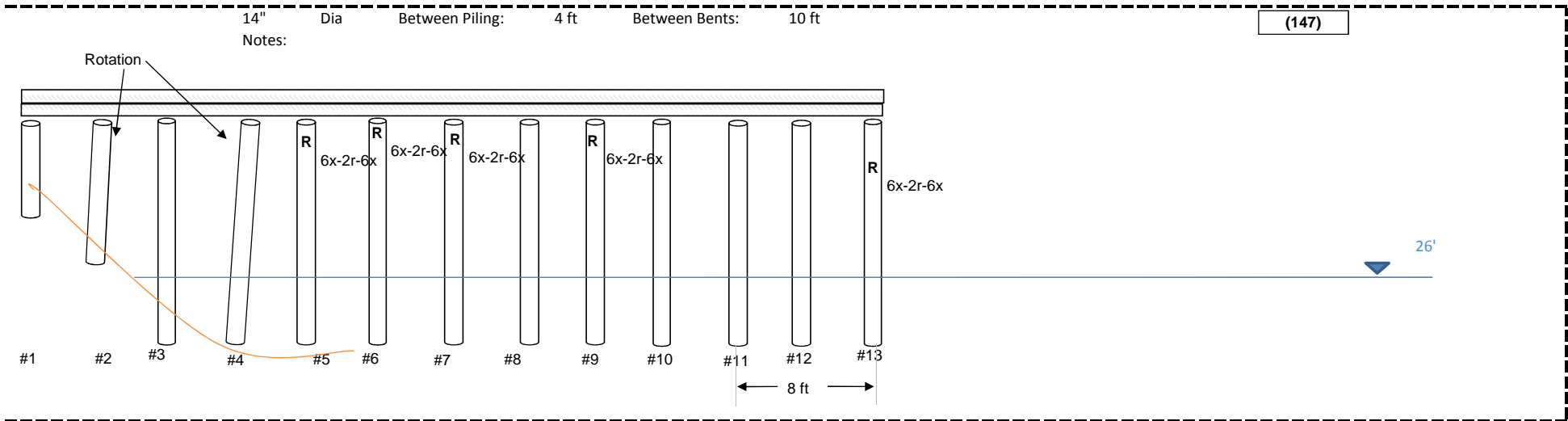

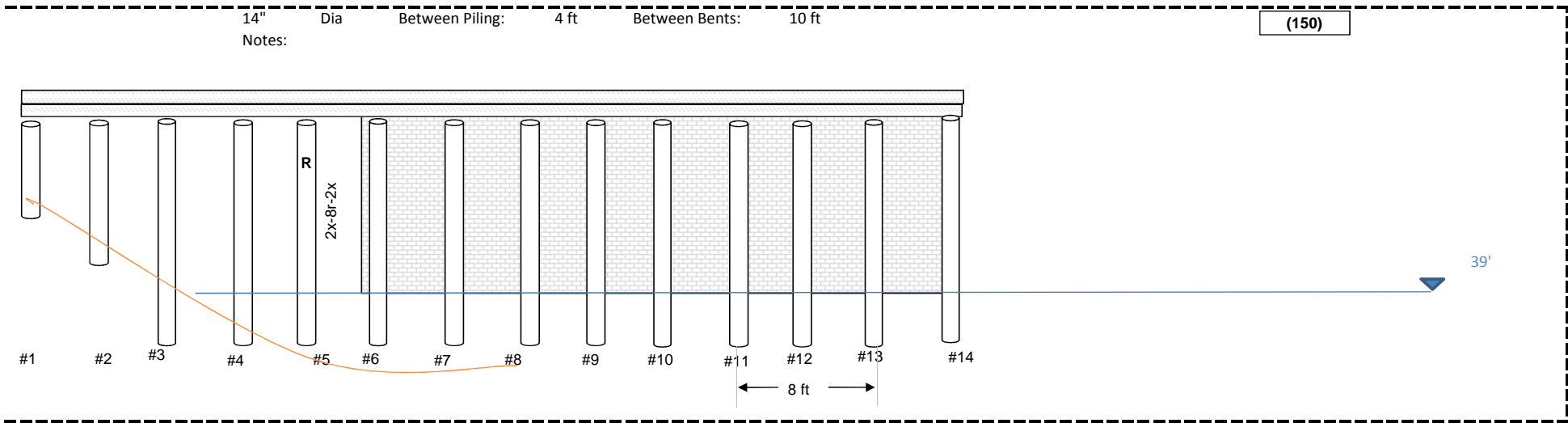
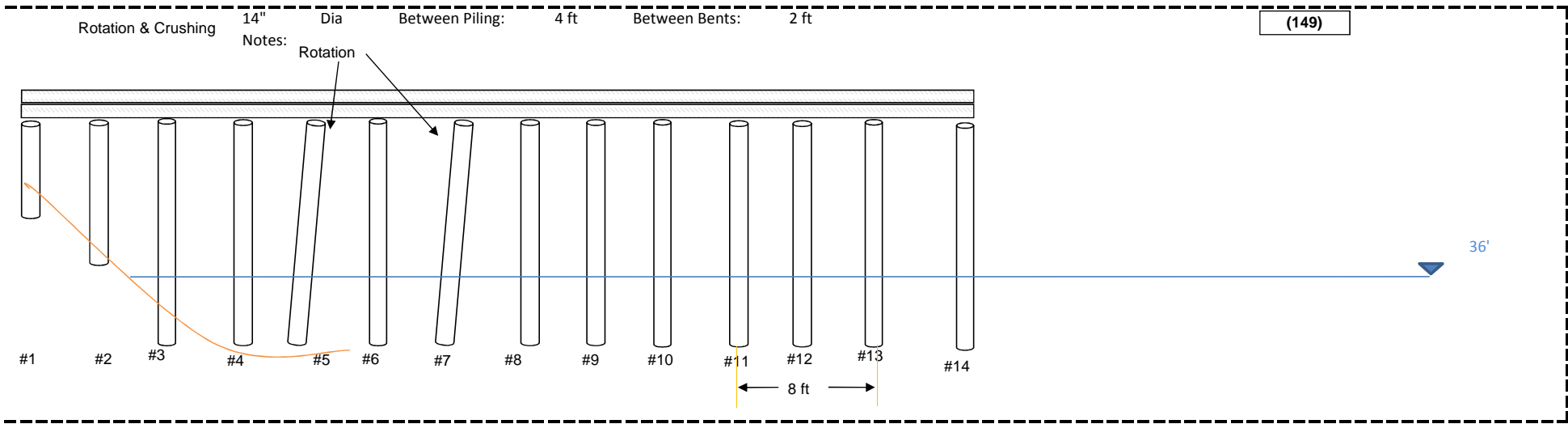

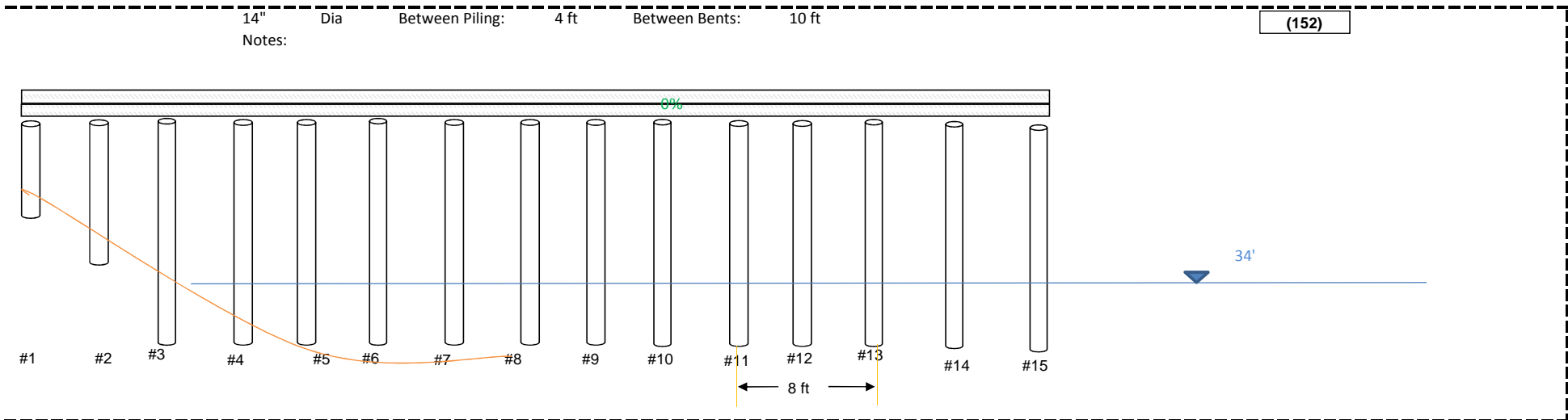
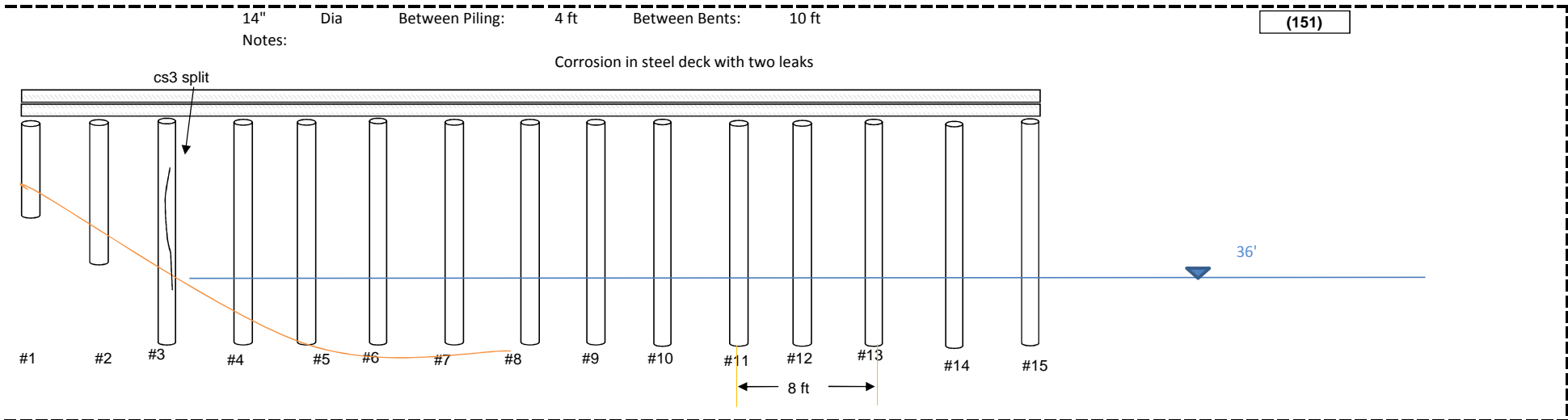

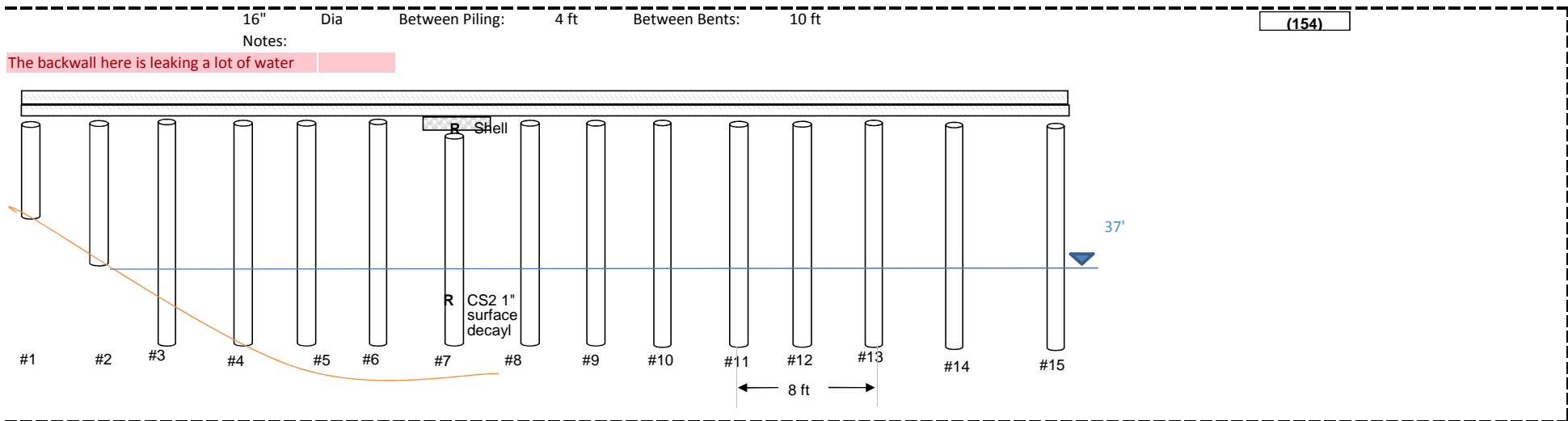
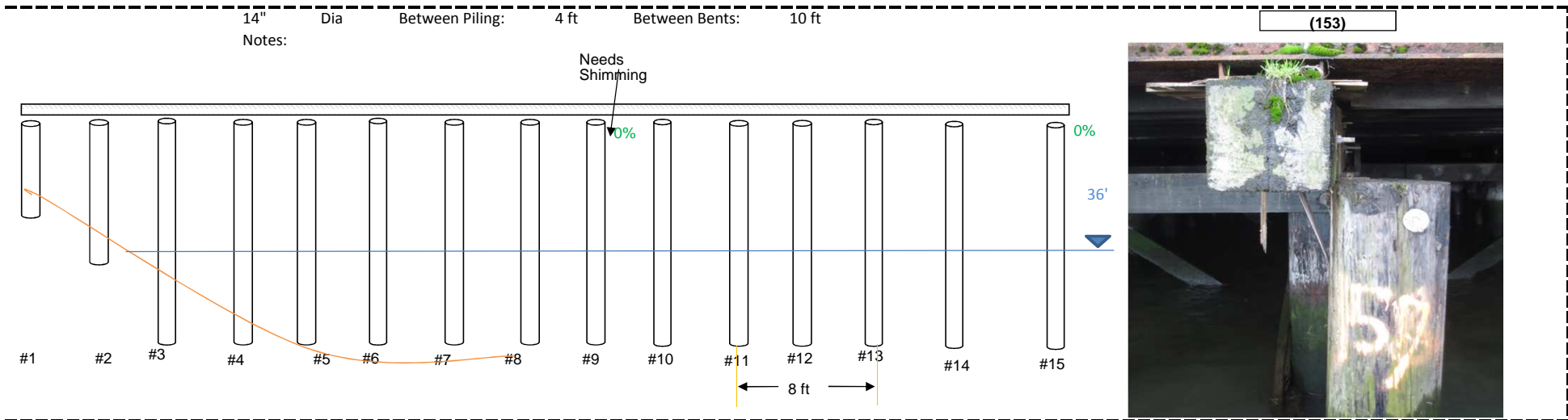

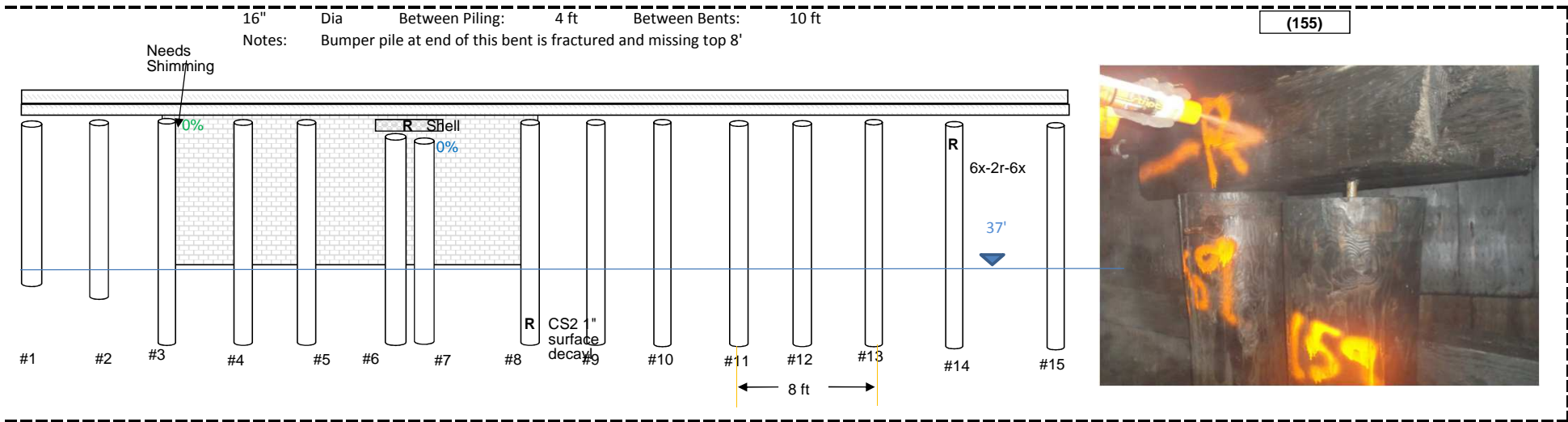

201.0619 28.27433 0.140625

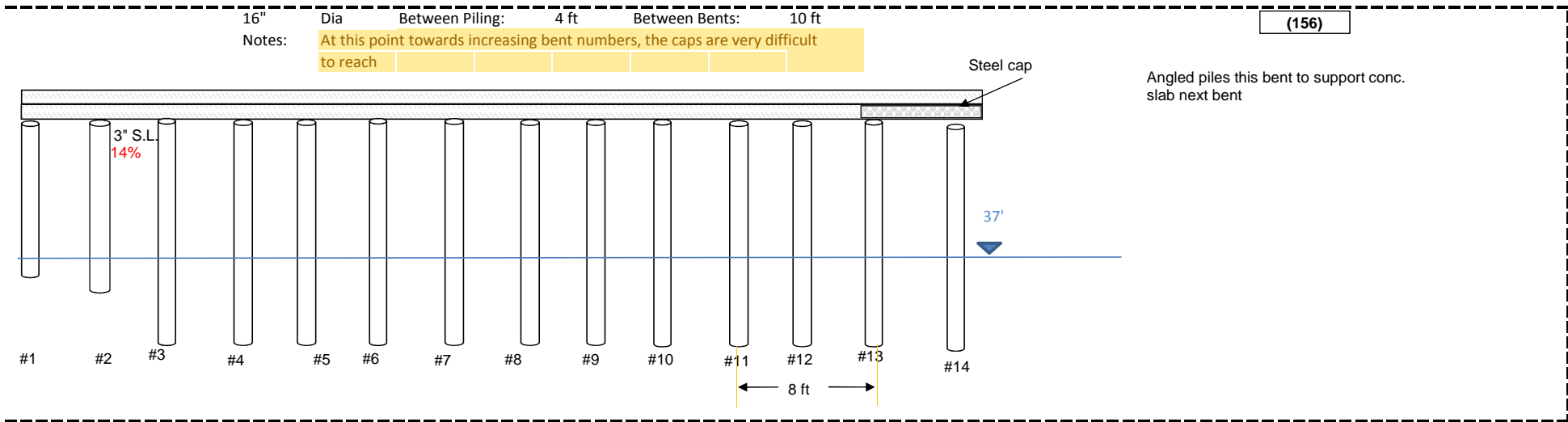

16" Dia Between Piling: 4 ft Between Bents: 10 ft
Notes:

(157)

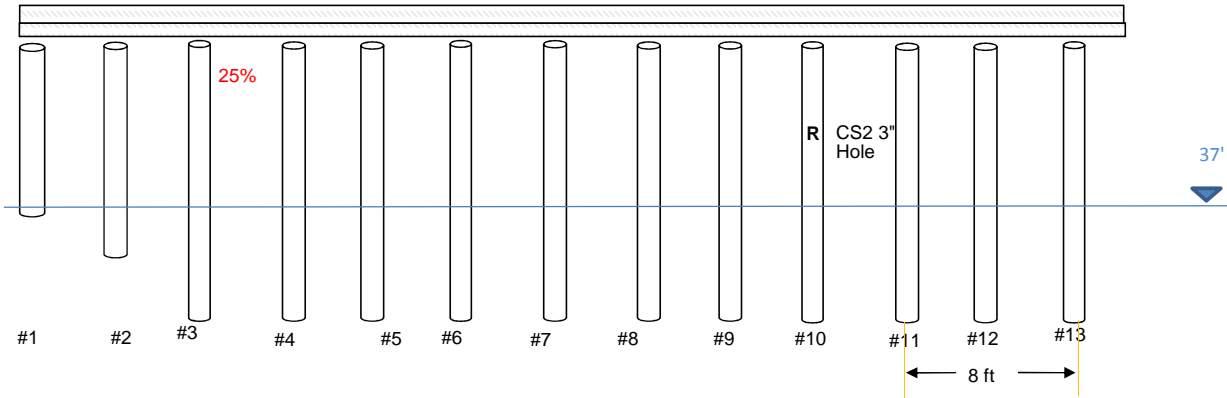

16" Dia Between Piling: 4 ft Between Bents: 10 ft
Notes:

(157a)

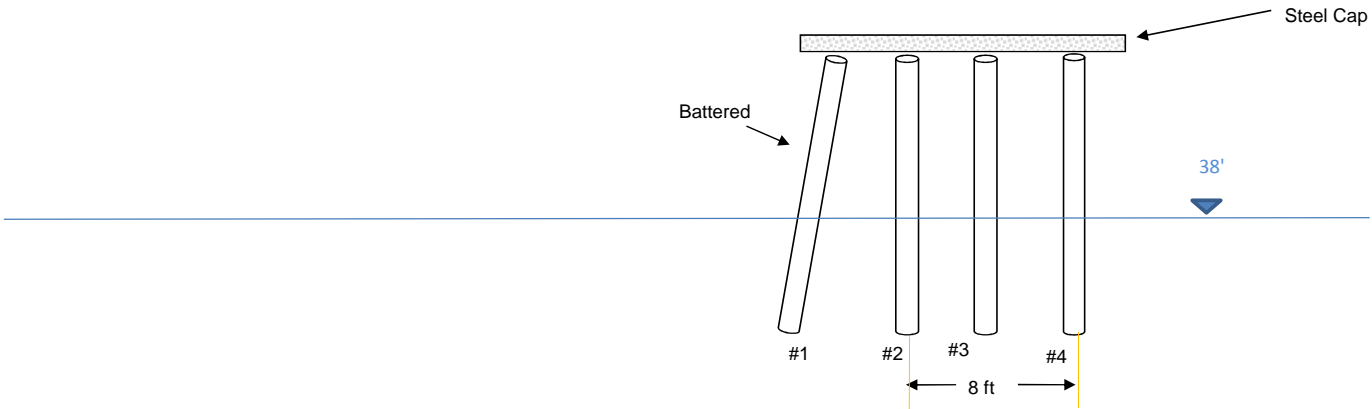

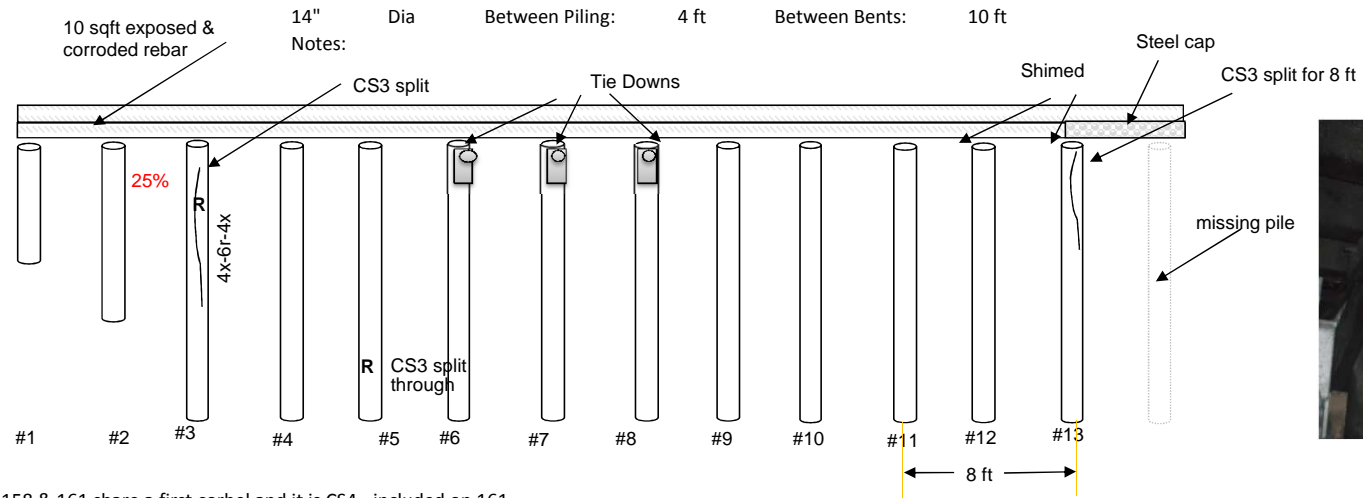

(158)



158 & 161 share a first corbel and it is CS4 - included on 161

14" Dia Between Piling: 4 ft Between Bents: 10 ft
Notes:

(159)

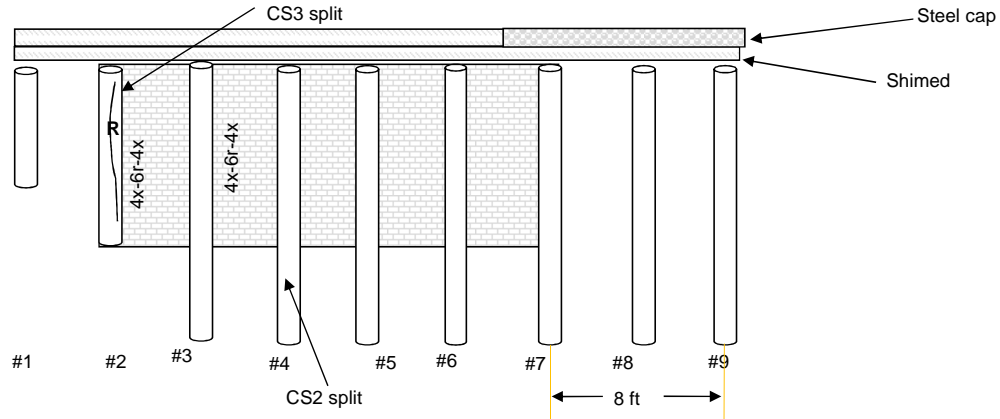

14" Dia Between Piling: 5ft Between Bents: 12 ft
Notes: Radial Bent

(160)

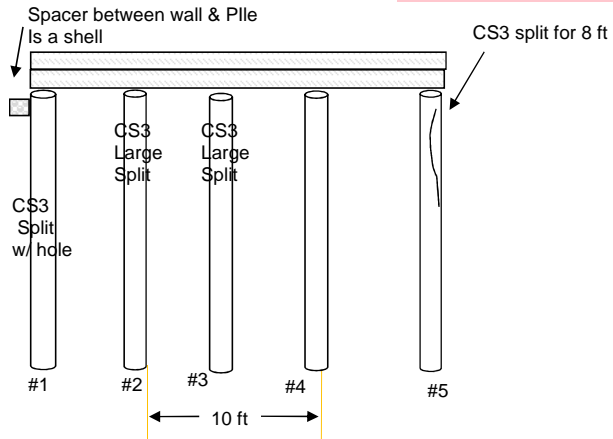

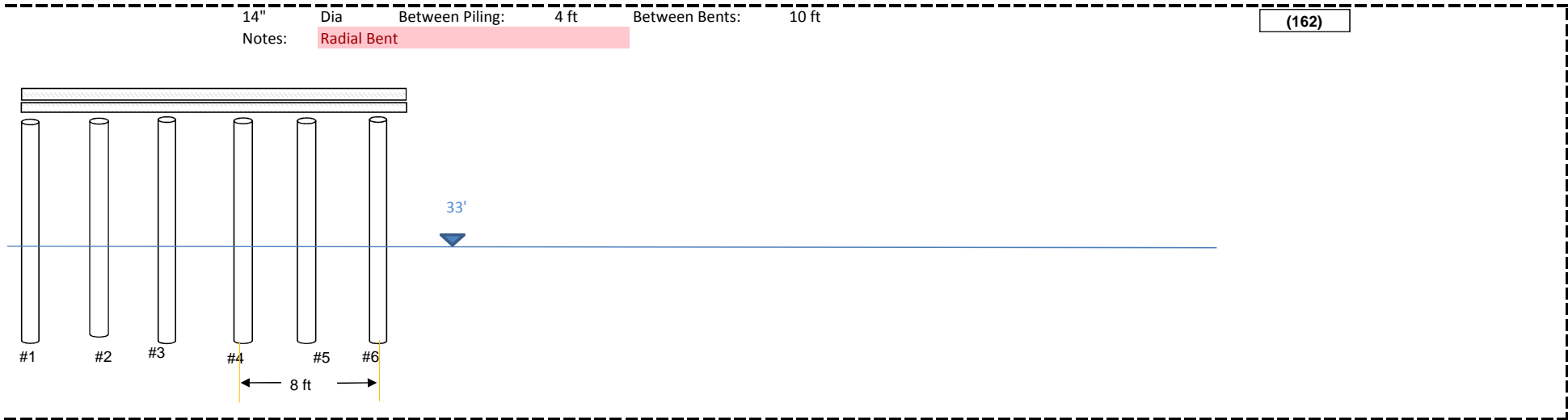
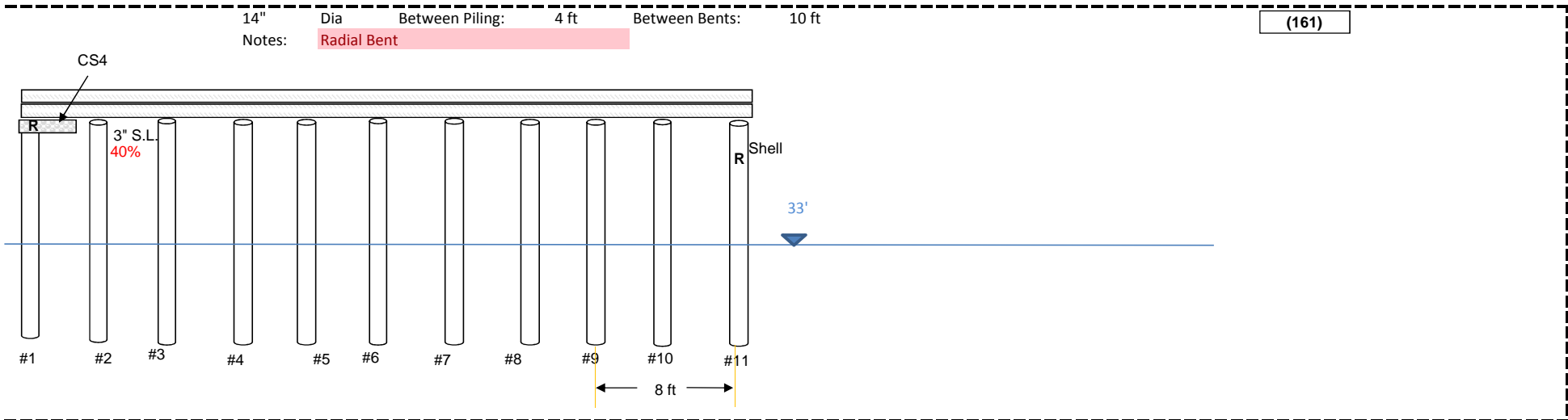

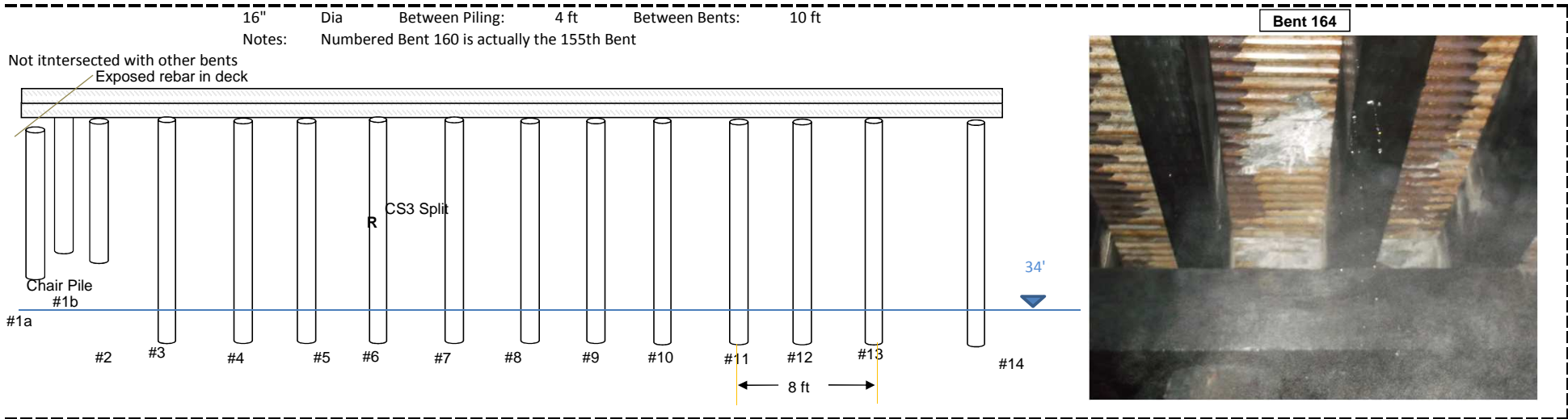
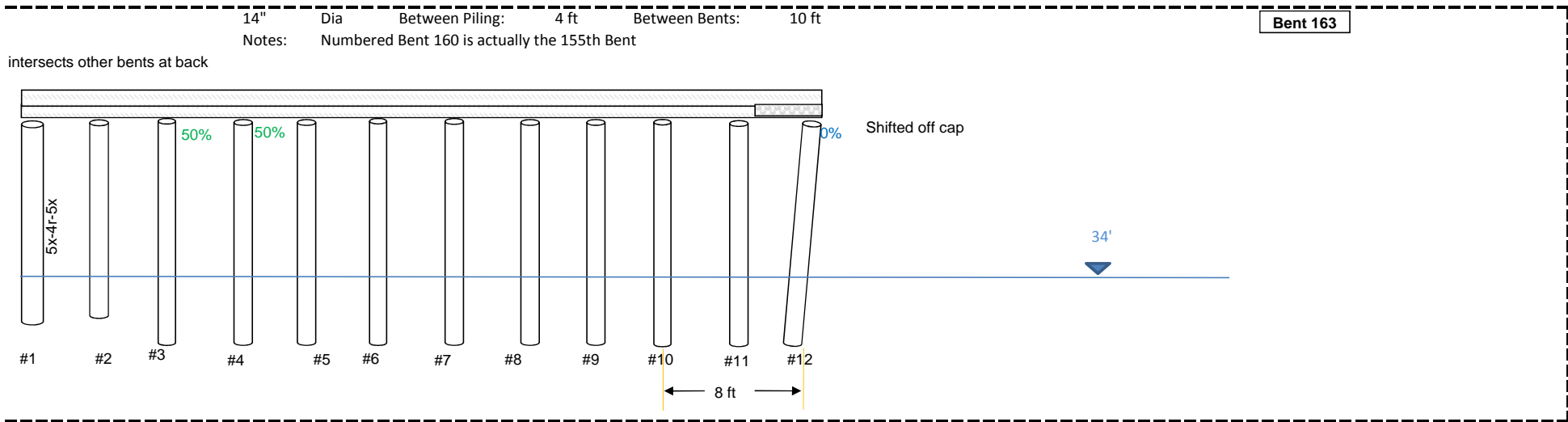

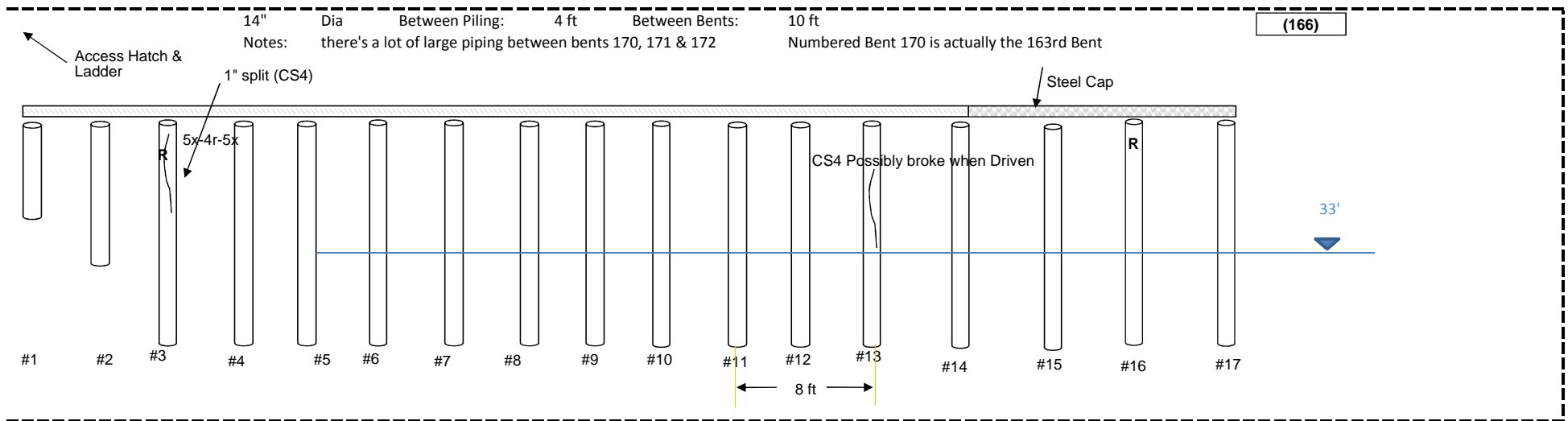
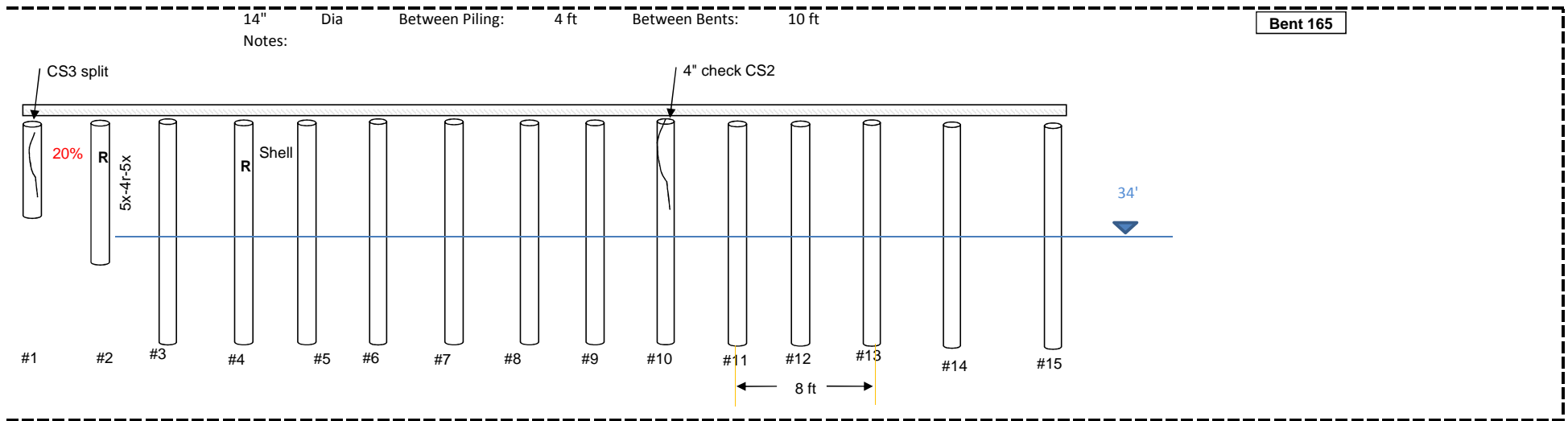

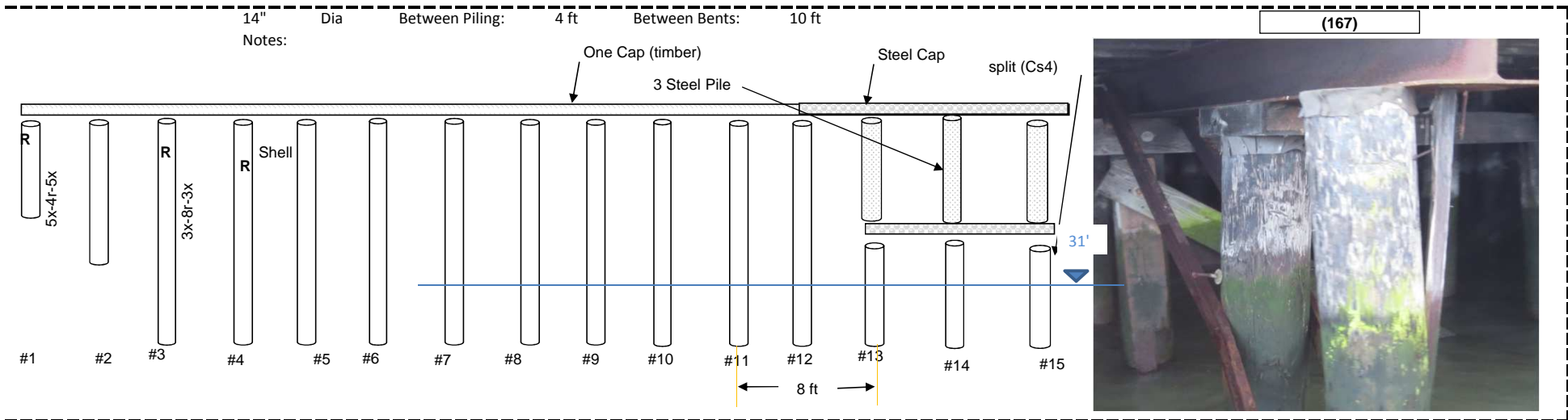

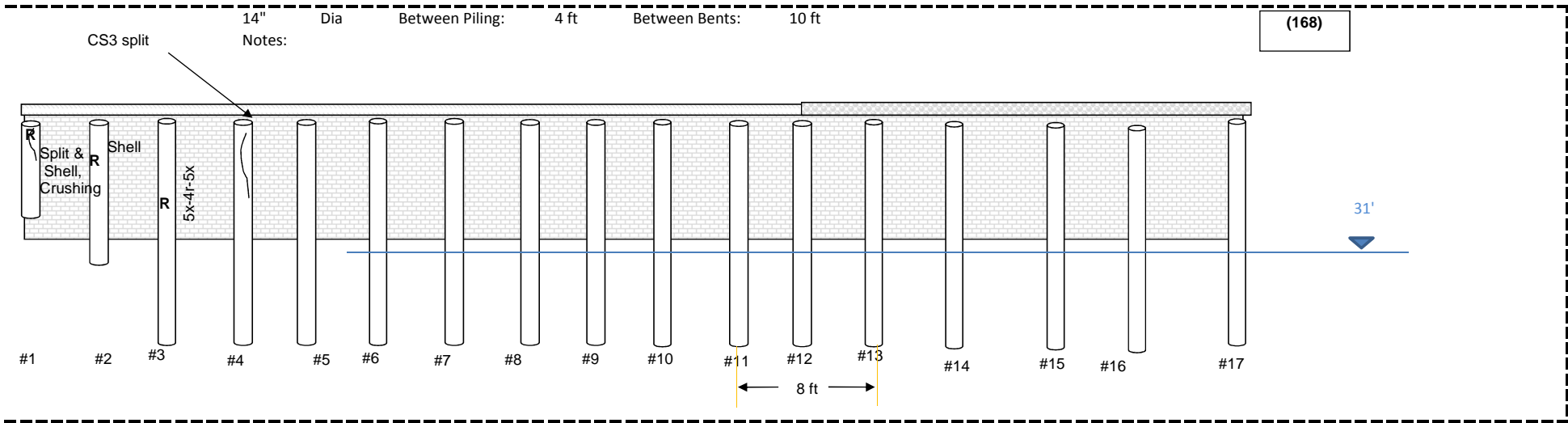

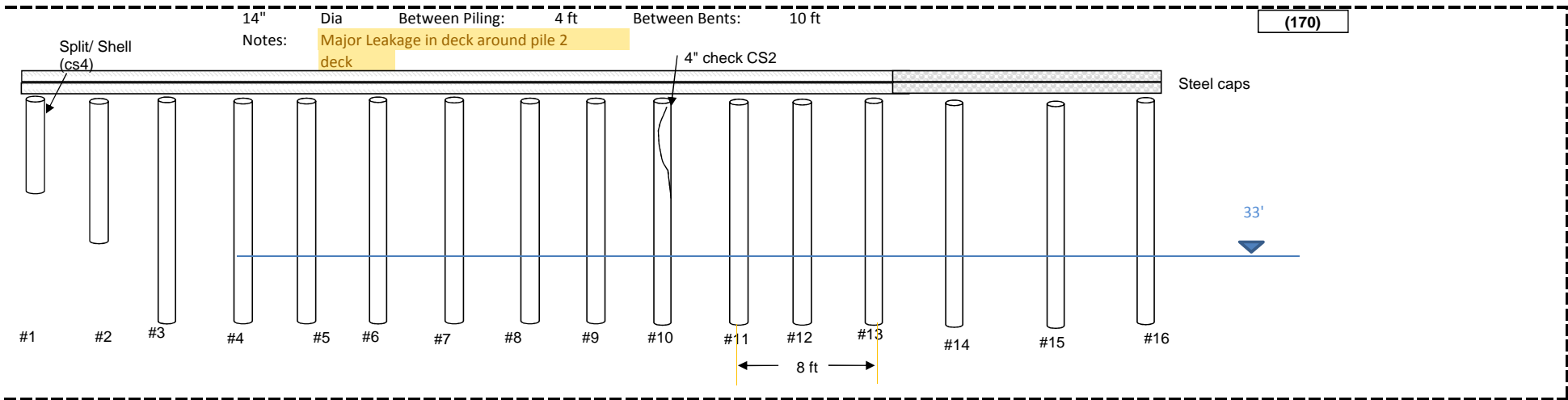
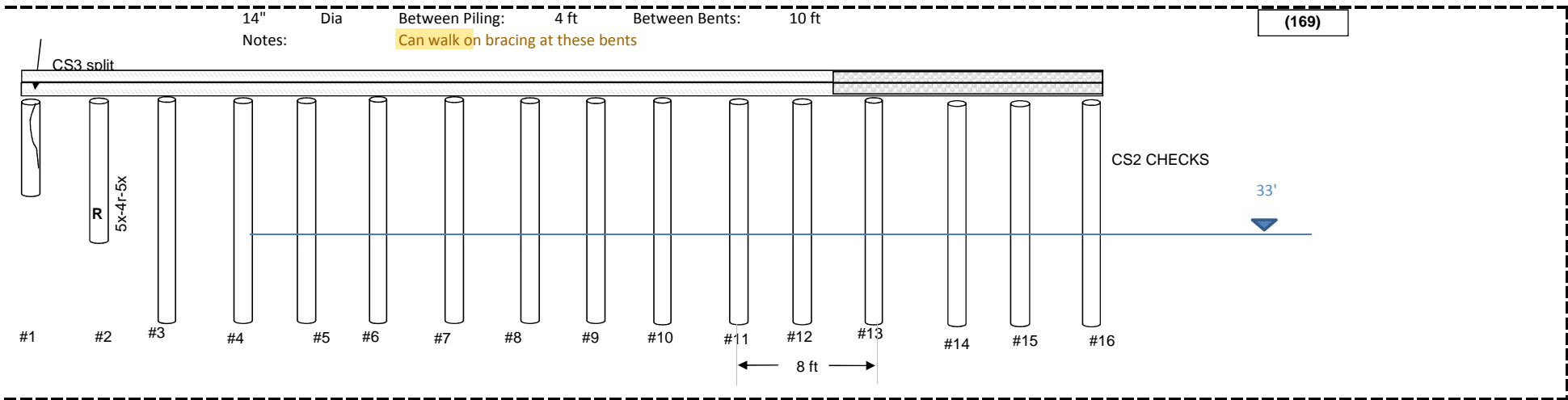

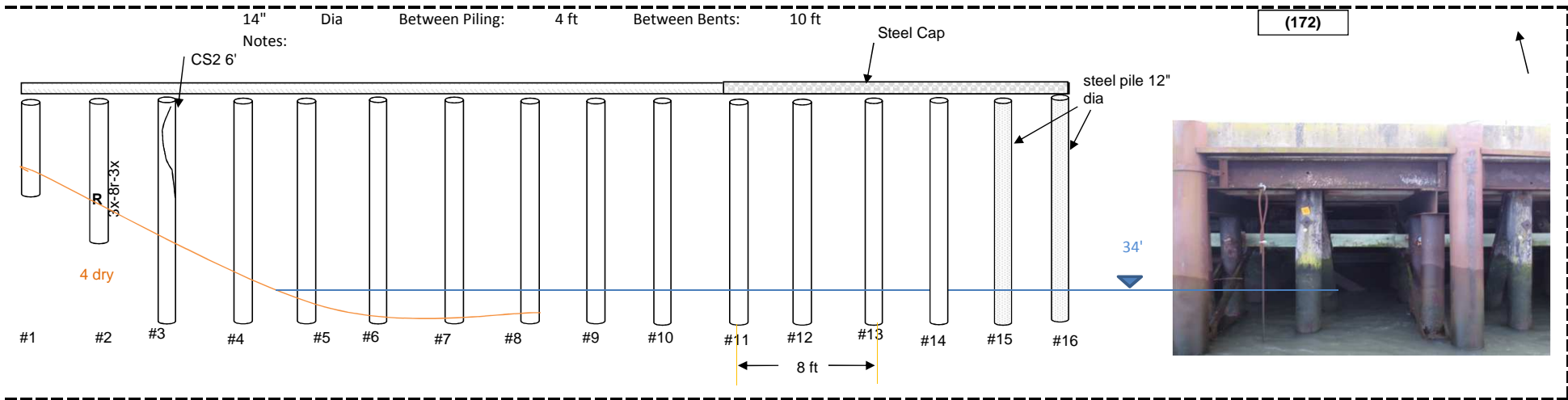
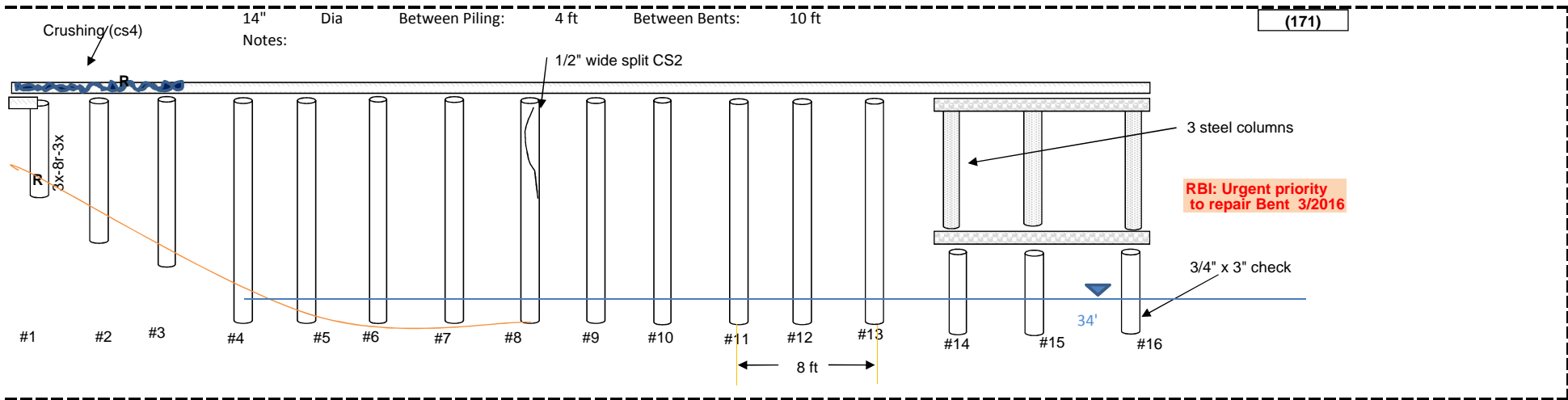

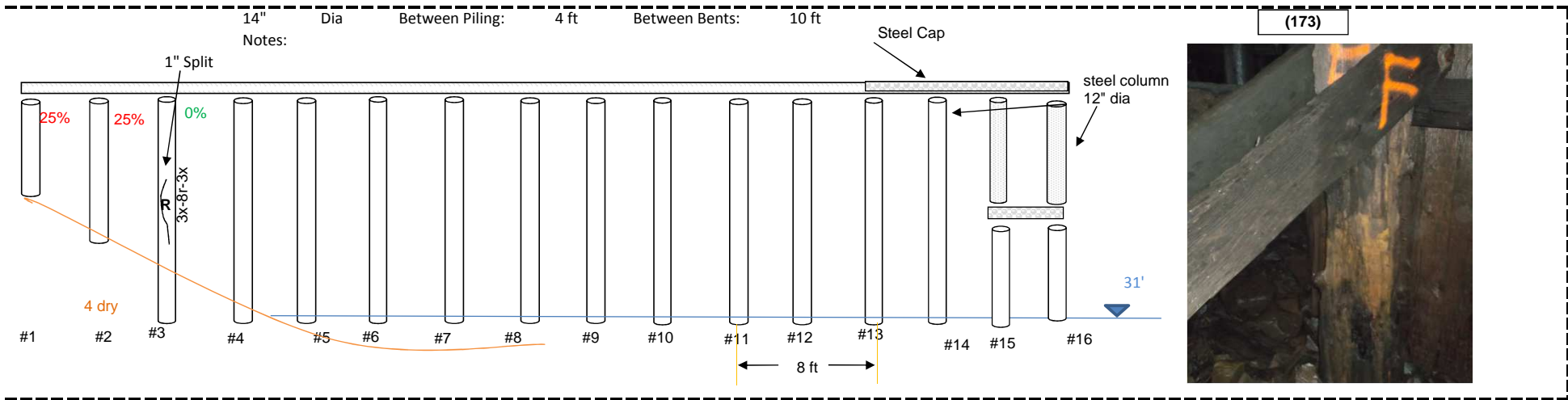

(173)

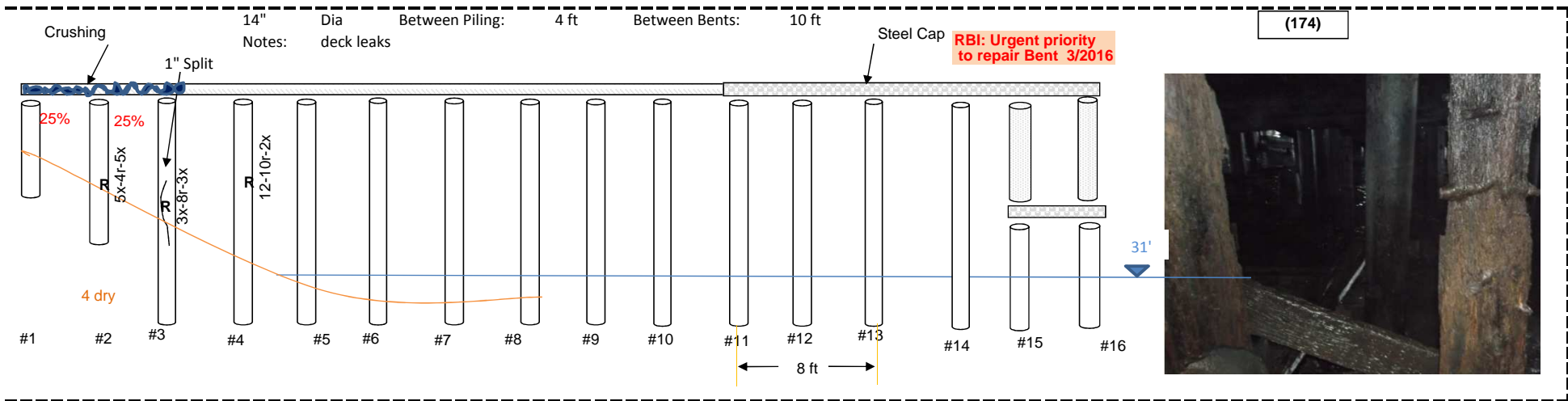

(174)

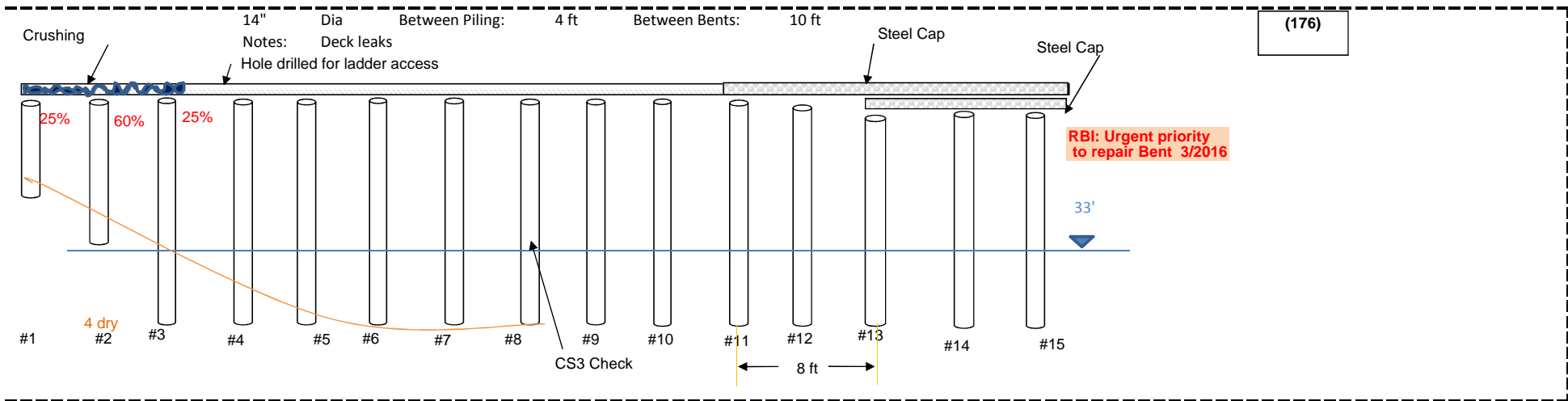
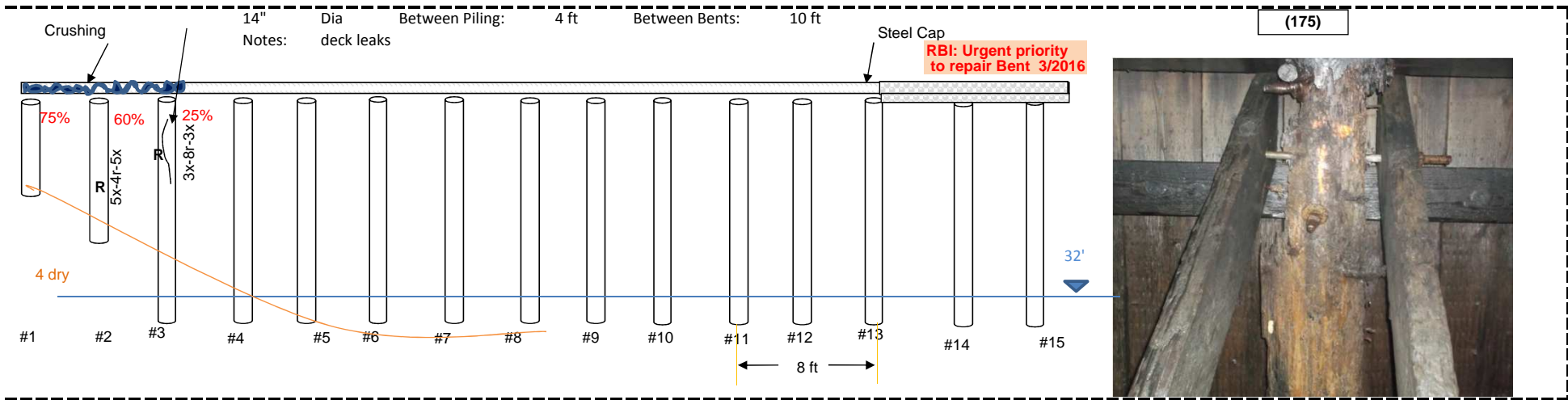

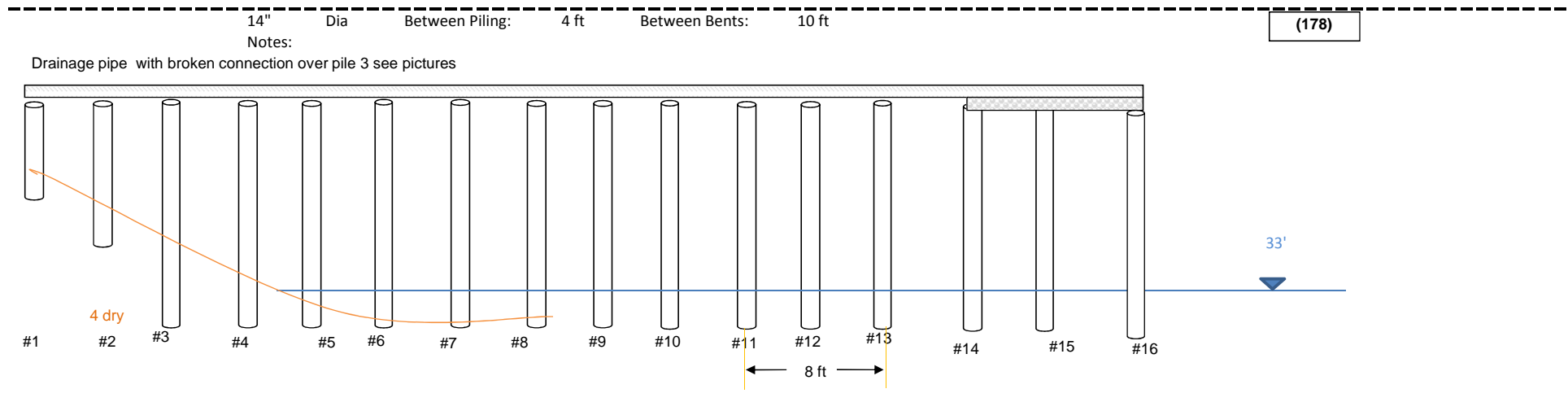
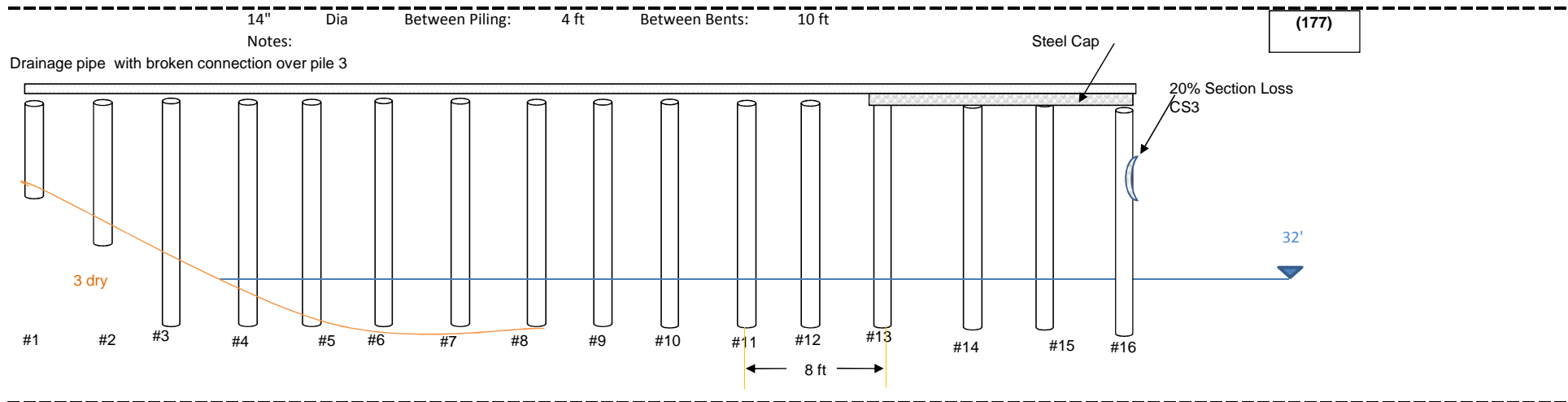

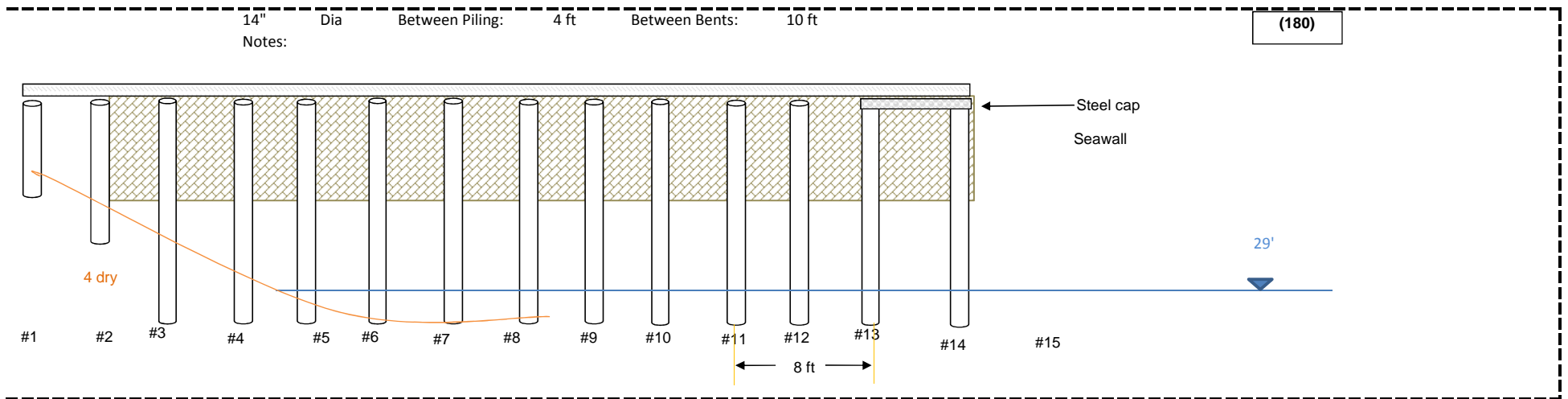
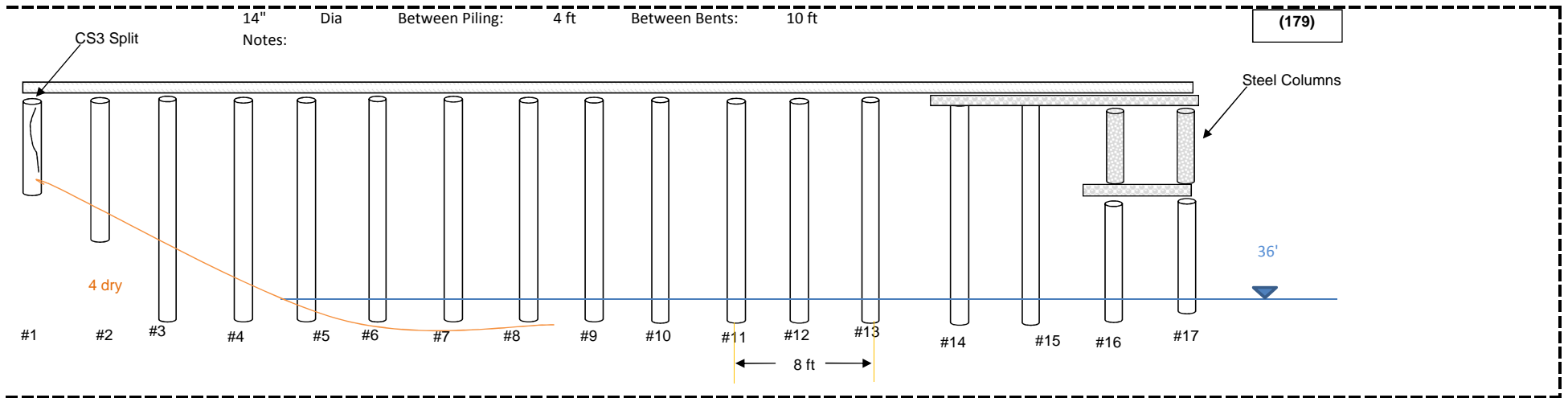

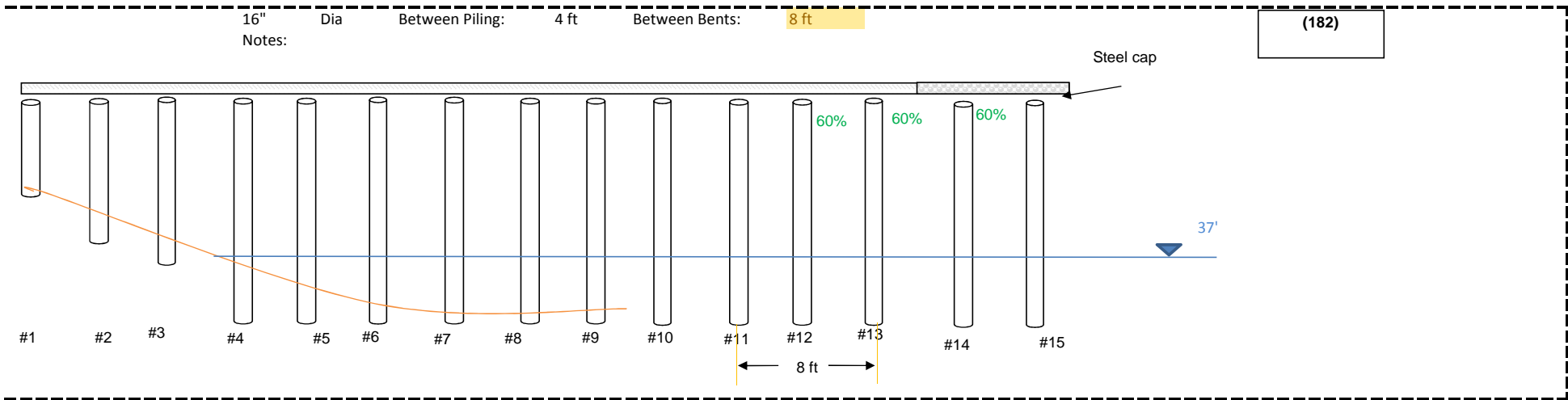
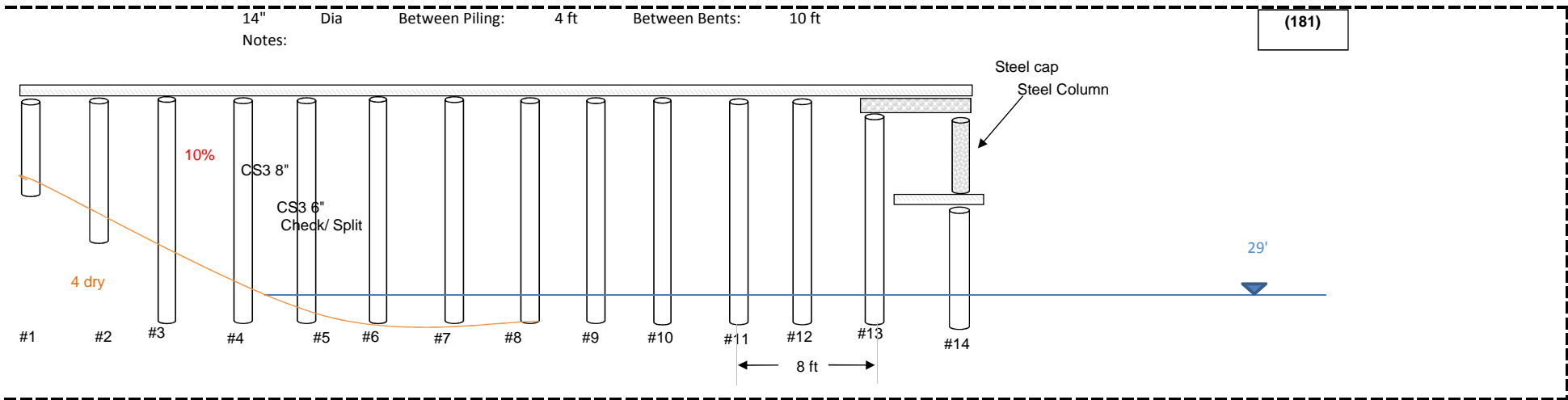

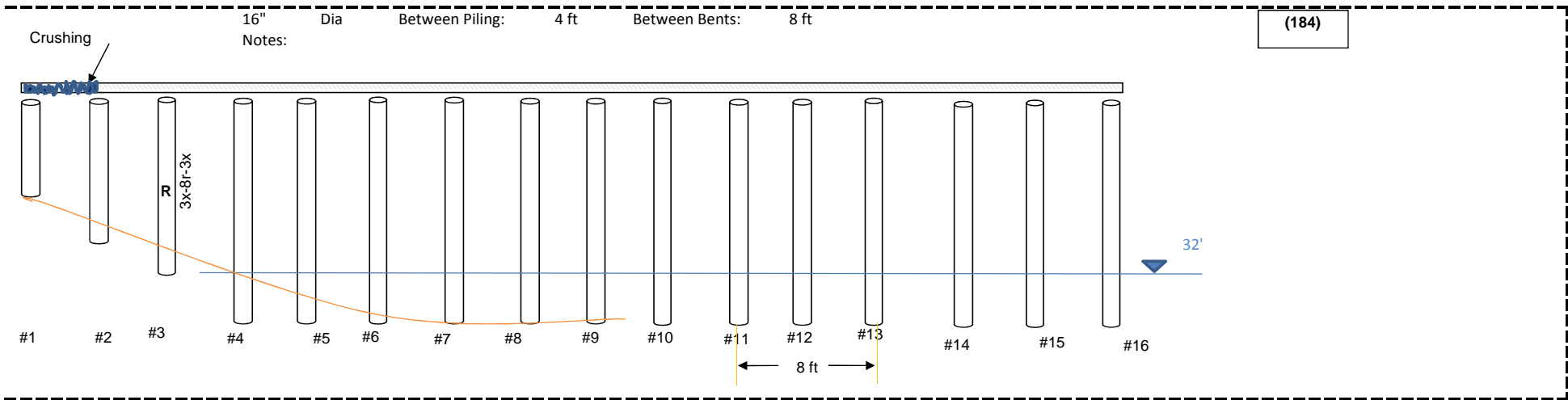
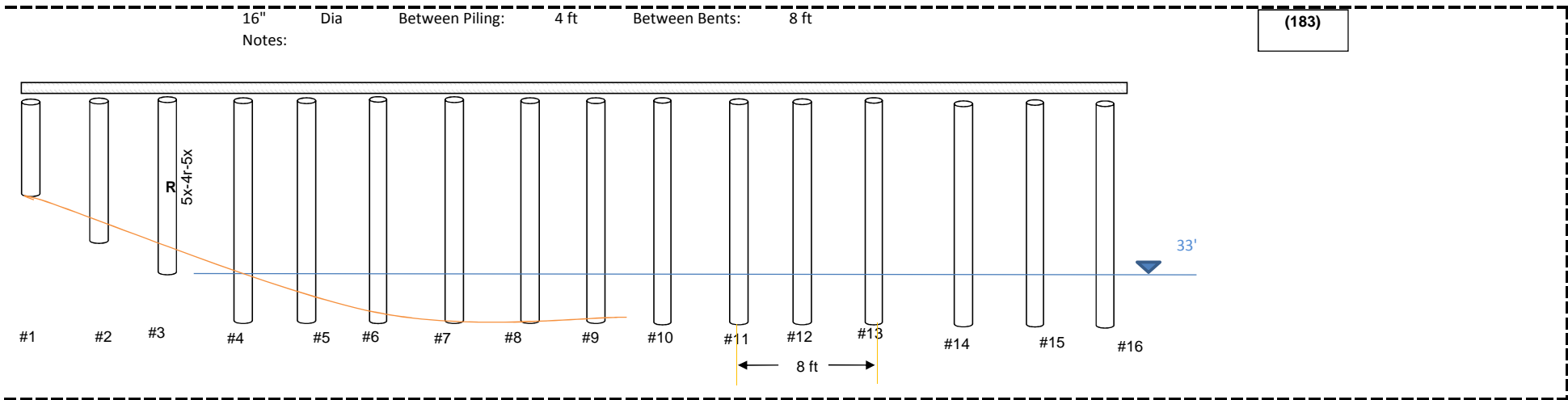

16" Dia Between Piling: 4 ft Between Bents: 8 ft
Notes:

(185)

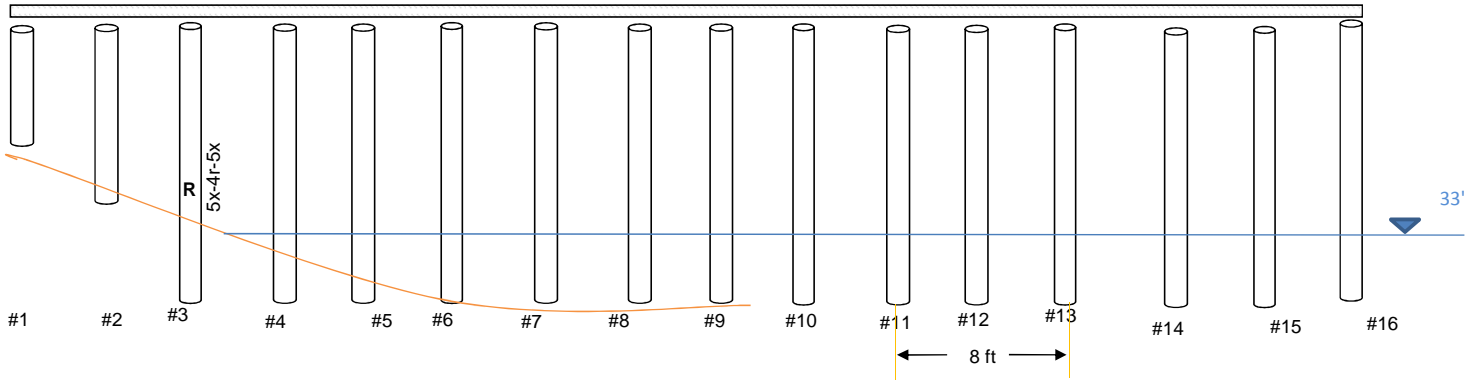

16" Dia Between Piling: 4 ft Between Bents: 8 ft
Notes:

(186)

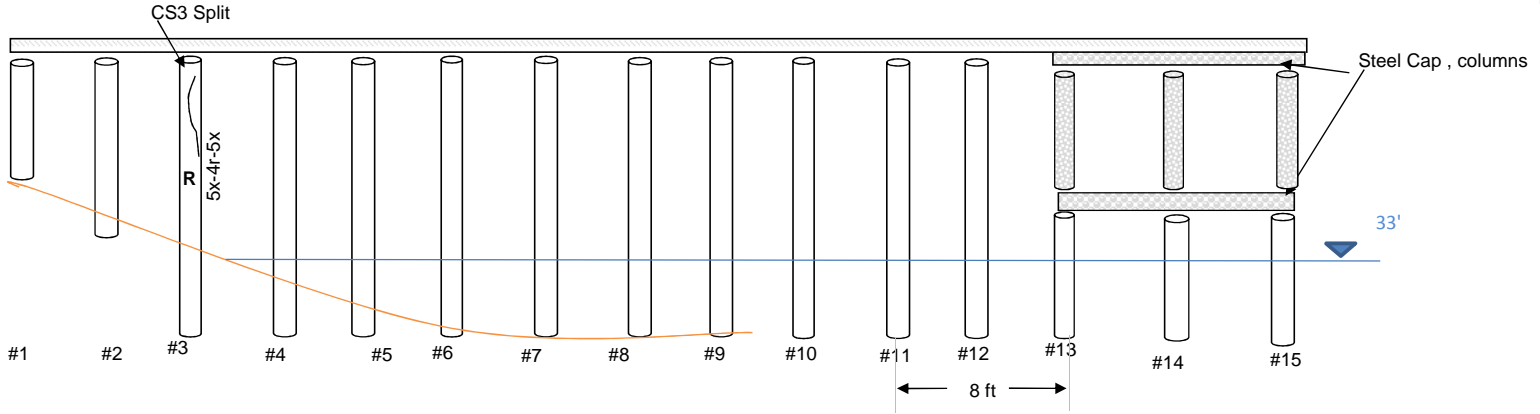

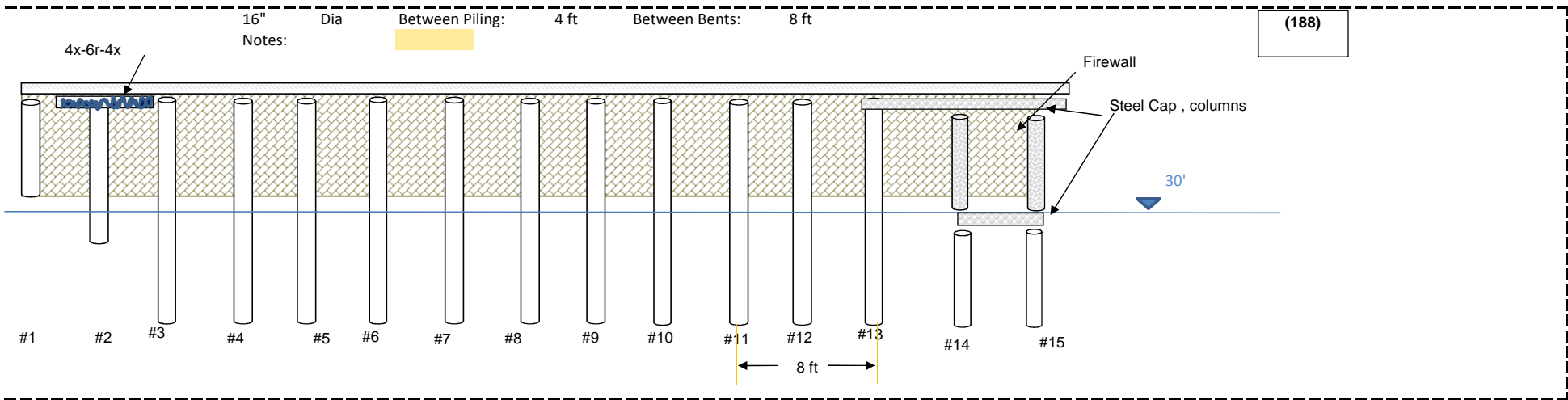
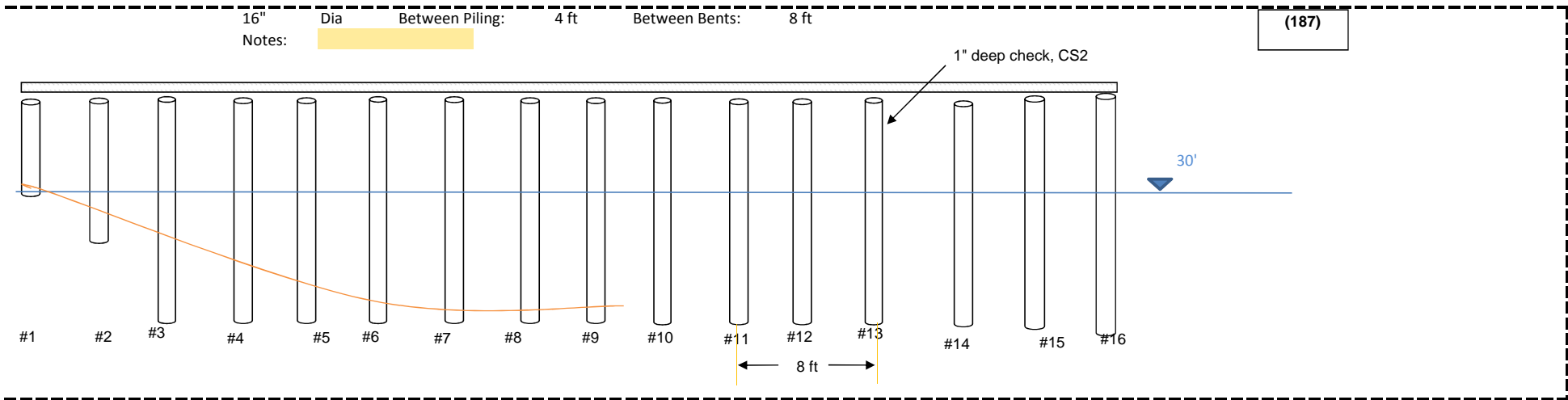

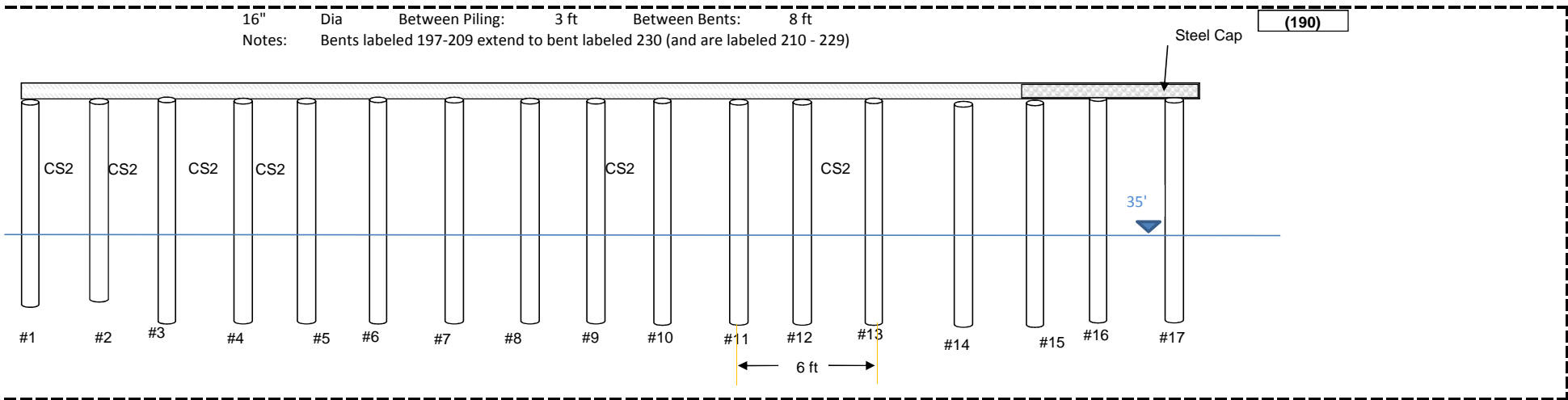
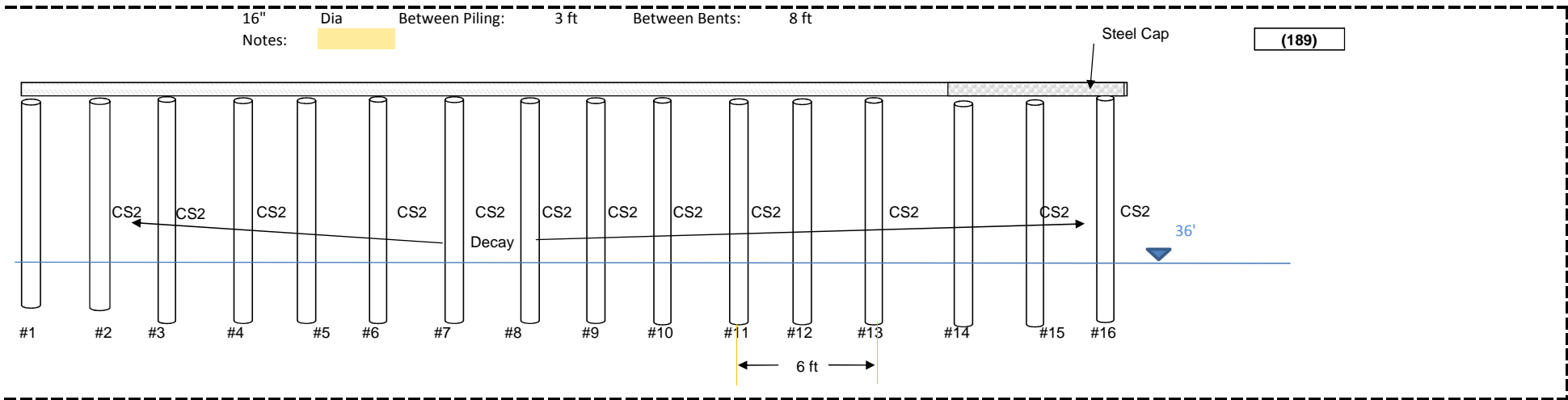

16" Dia Between Piling: 3 ft Between Bents: 8 ft
Notes: Bents labeled 197-209 extend to bent labeled 230 (and are labeled 210 - 229)

(191)

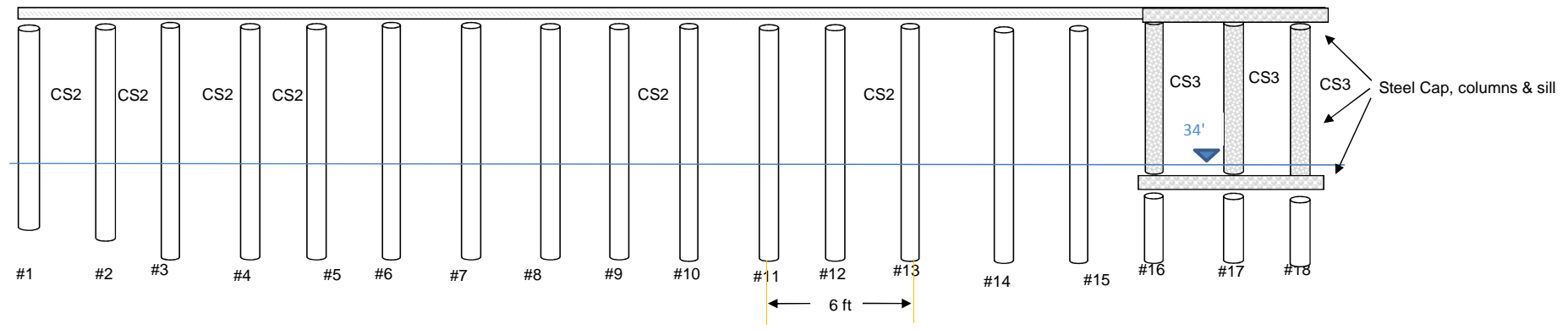

16" Dia Between Piling: 4 ft Between Bents: 8 ft
Notes: Bents labeled 197-209 extend to bent labeled 230 (and are labeled 210 - 229)

(192)

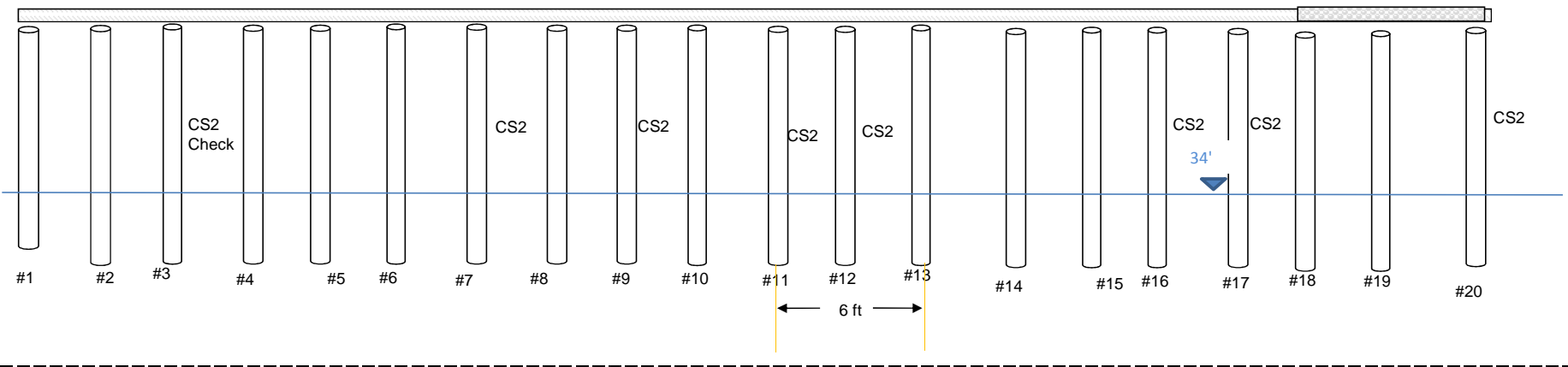

16" Dia Between Piling: 3 ft Between Bents: 8 ft
Notes: Bents labeled 197-209 extend to bent labeled 230 (and are labeled 210 - 229)
The other end of bent 201 is labeled 230

(193)

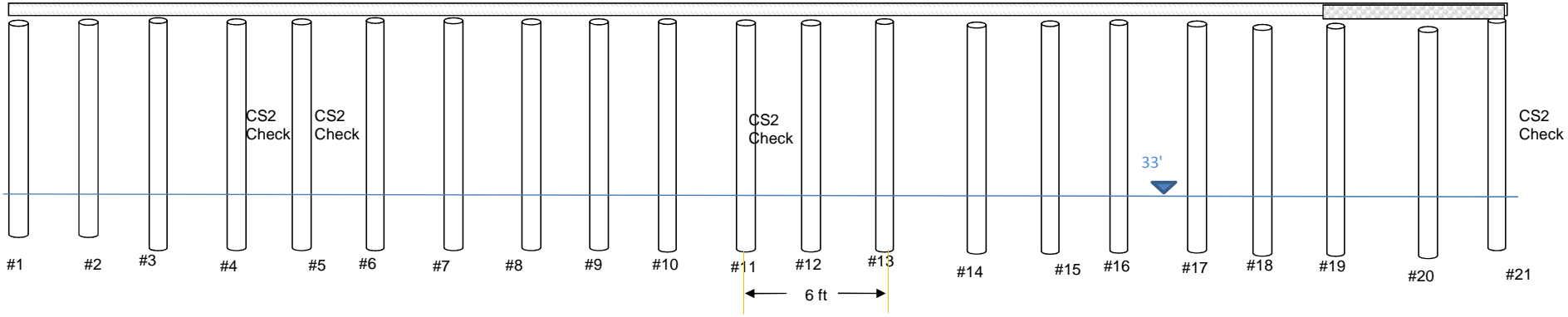

16" Dia Between Piling: 3 ft Between Bents: 8 ft
Notes: Bents labeled 197-209 extend to bent labeled 230 (and are labeled 210 - 229)
The other end of bent 201 is labeled 229

(194)

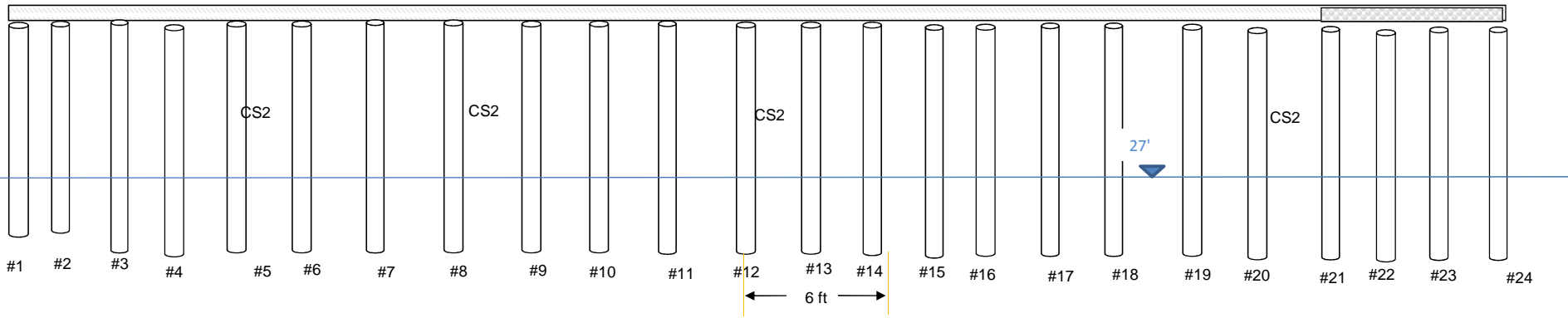

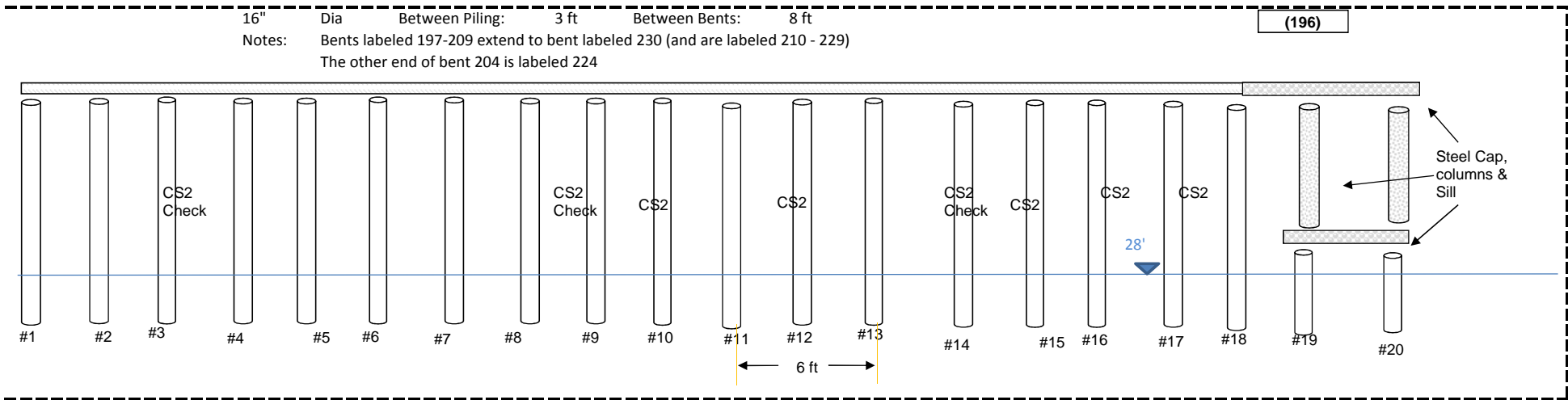
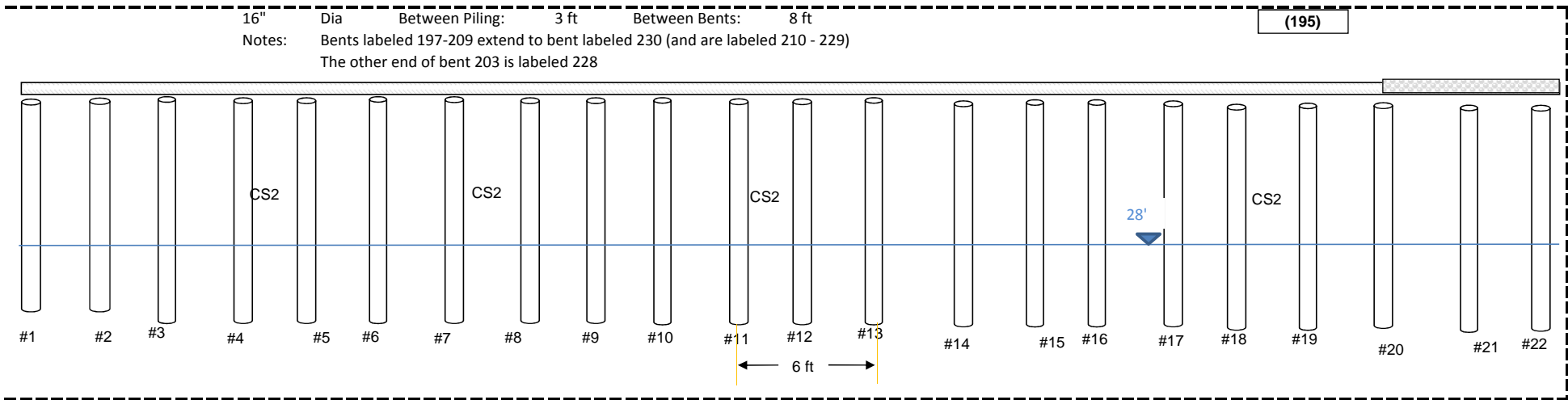

16" Dia Between Piling: 4 ft Between Bents: 8 ft
Notes: Bents labeled 197-209 extend to bent labeled 230 (and are labeled 210 - 229)
The other end of bent 205 is labeled 220

(197)

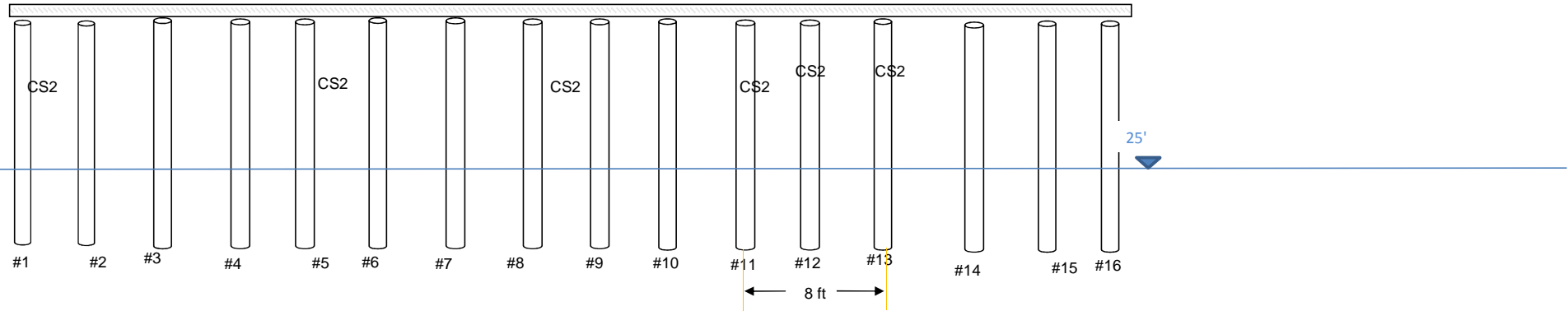

16" Dia Between Piling: 4 ft Between Bents: 8 ft
Notes:

(198)

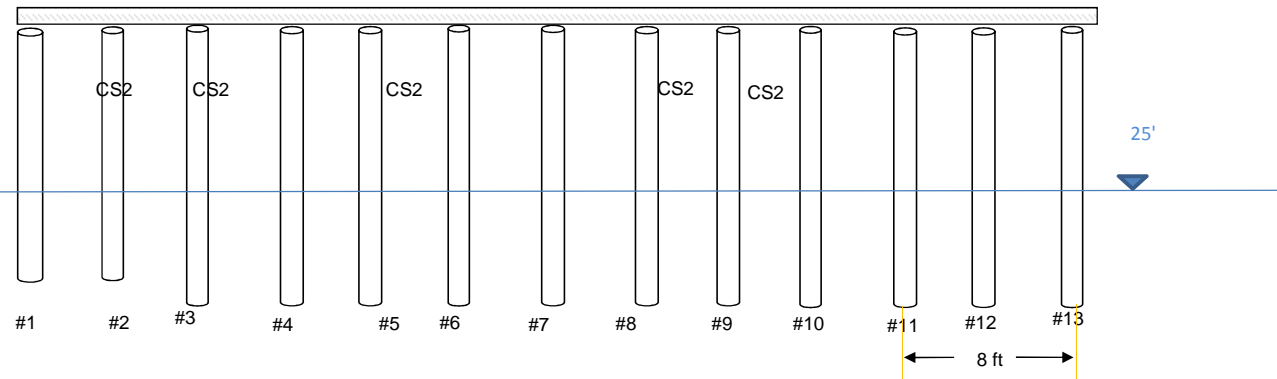

16" Dia Between Piling: 4 ft Between Bents: 8 ft

(199)

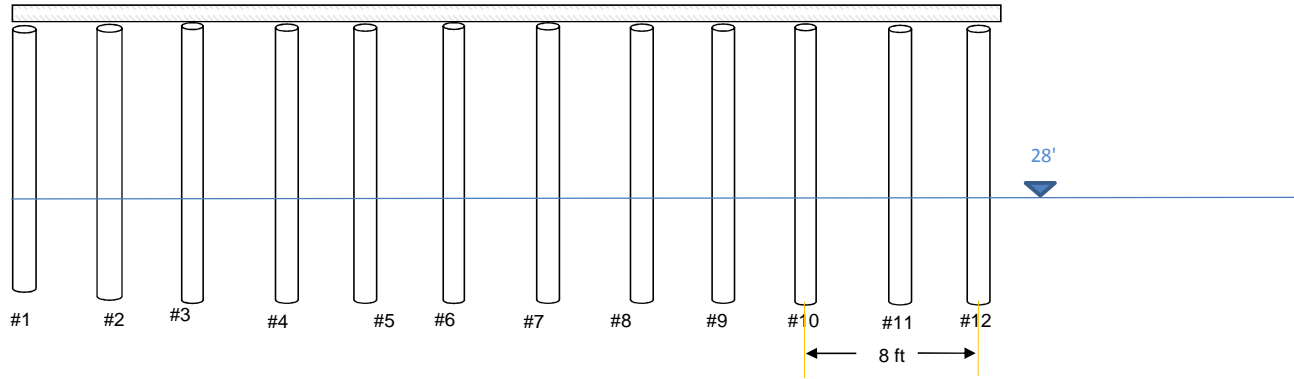

16" Dia Between Piling: 4 ft Between Bents: 4 ft
Notes:

Bent 199A

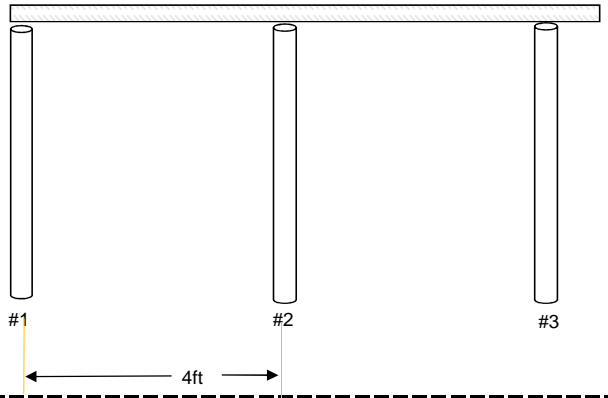

16" Dia Between Piling: 4 ft Between Bents: 8 ft
Notes:

(200)

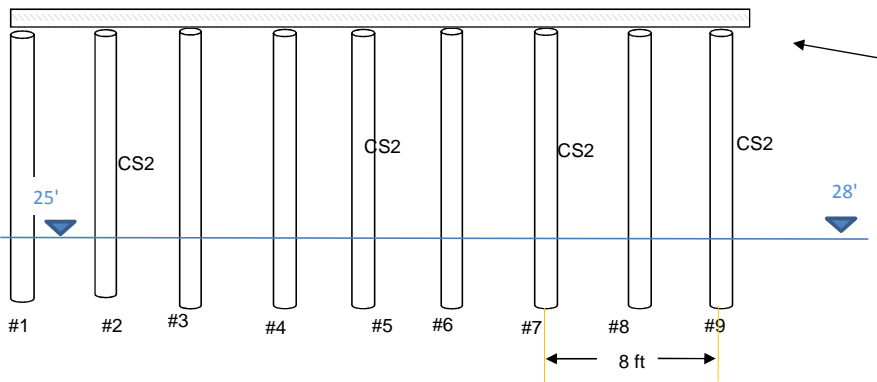

Overhang/
missing piles



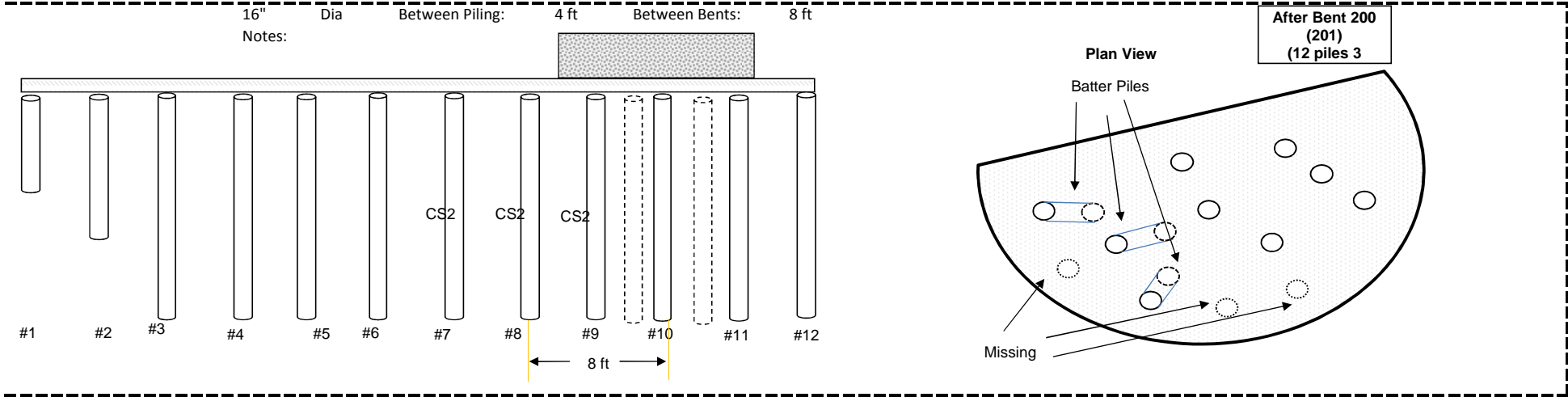

Port of Astoria Pier 2
 Results of Inspection 9/2015 & 1/2016
 Structure #22526

Cross Bracing & Girders generally not pictured
 Girders: 14 x 6.5" Spacing: 20" O.C.
 Caps are 14" x 14"

Blue Bearing Loss
 Red Section Loss

#22526 1/3
 No Bent 229

Unless otherwise noted, piles & columns - CS1, caps & girders - CS2

Note that Bents numbered on the site as 210-229 are just the other end of bents 201 to 189. See figure

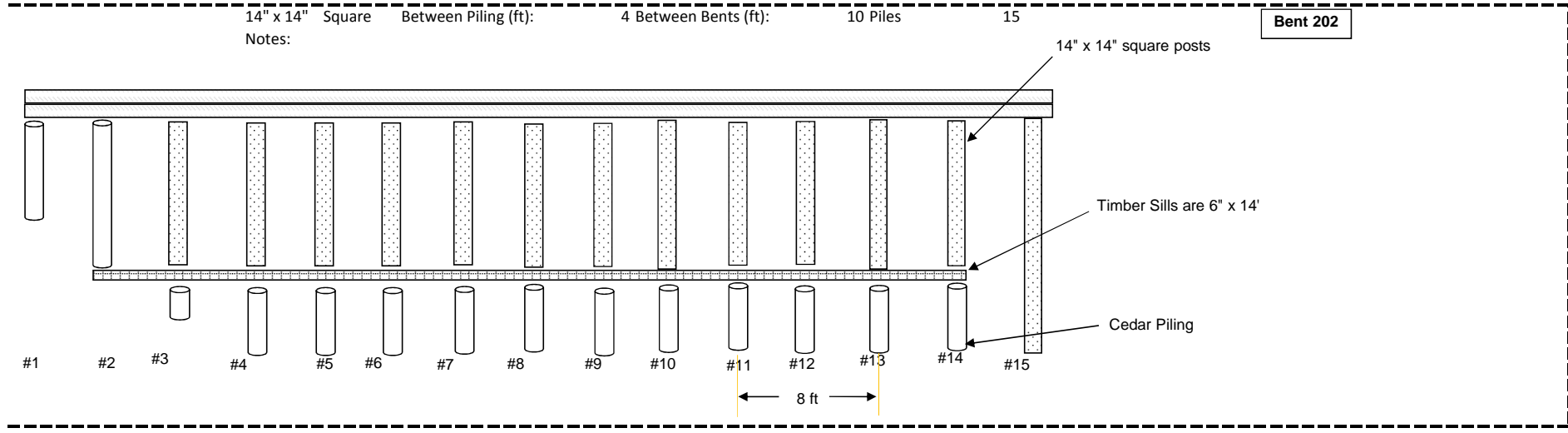

14" x 14" Square Between Piling (ft): 4 Between Bents (ft): 10 Piles 15
 Notes: Between 203 & 204 the deck is blowing out (see pictures) Bent 203

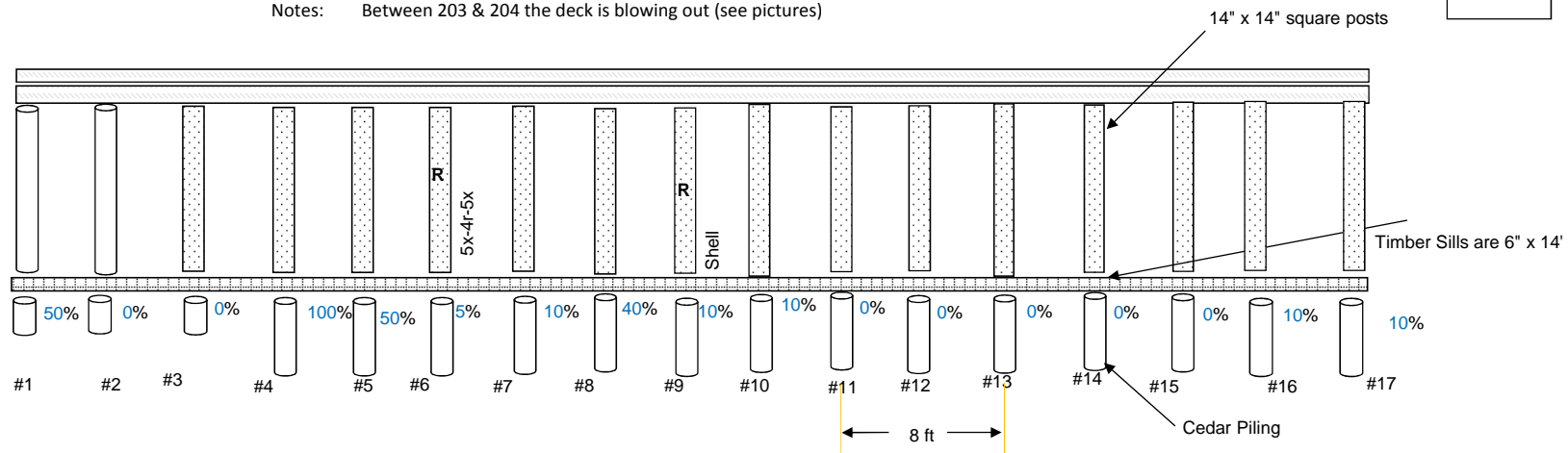

14" x 14" Square Between Piling (ft): 4 Between Bents (ft): 10 Piles 15
 Notes: Between 203 & 204 the deck is blowing out (see pictures) Bent 204

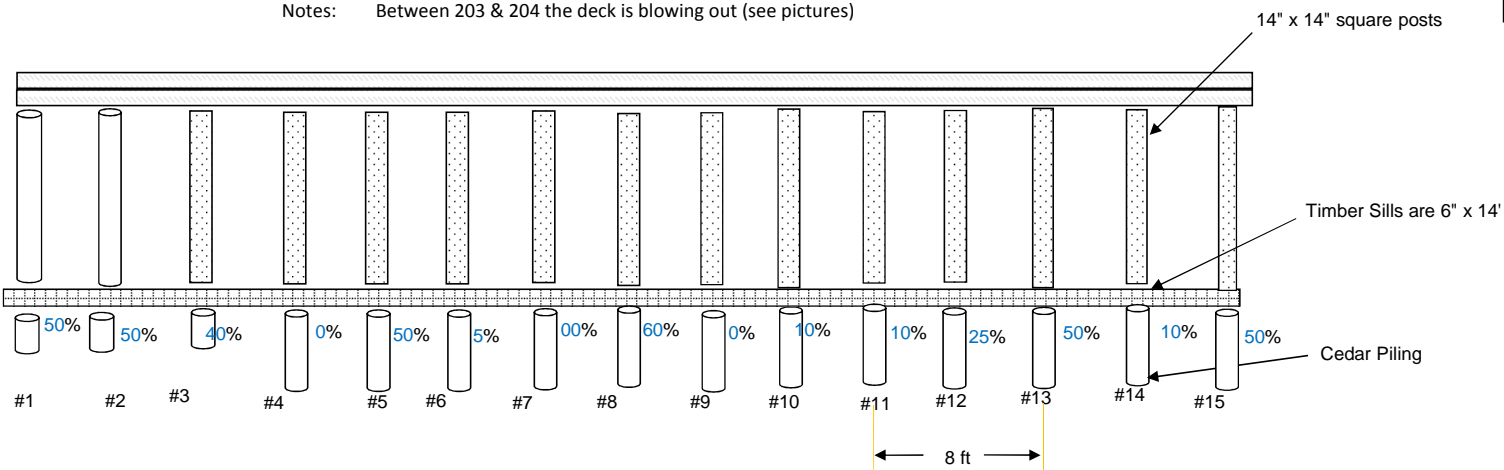

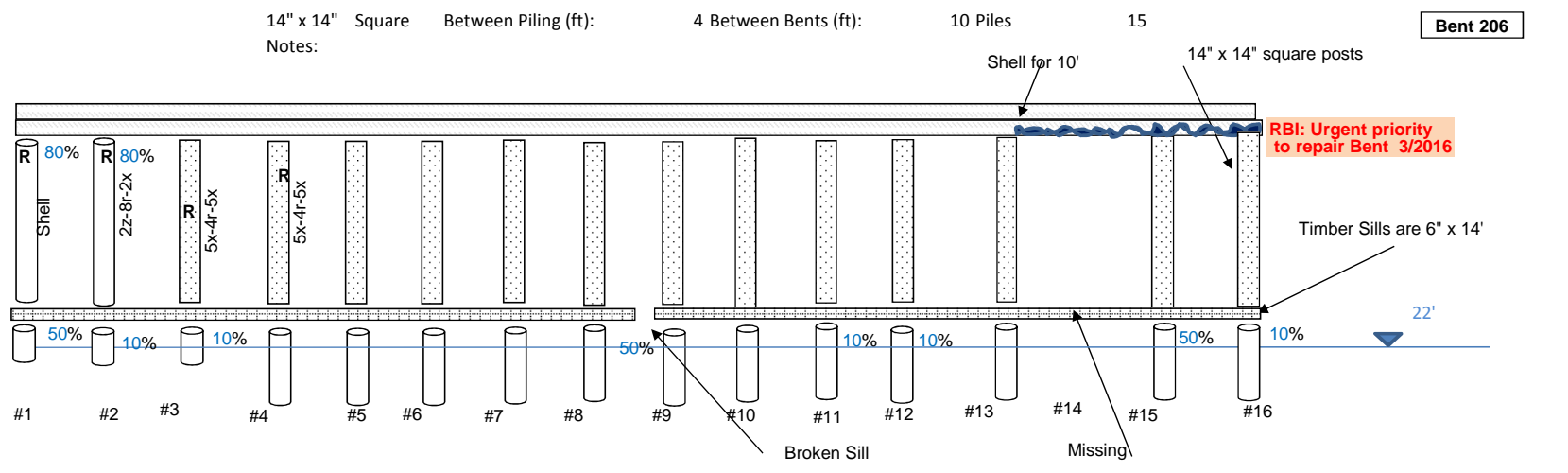
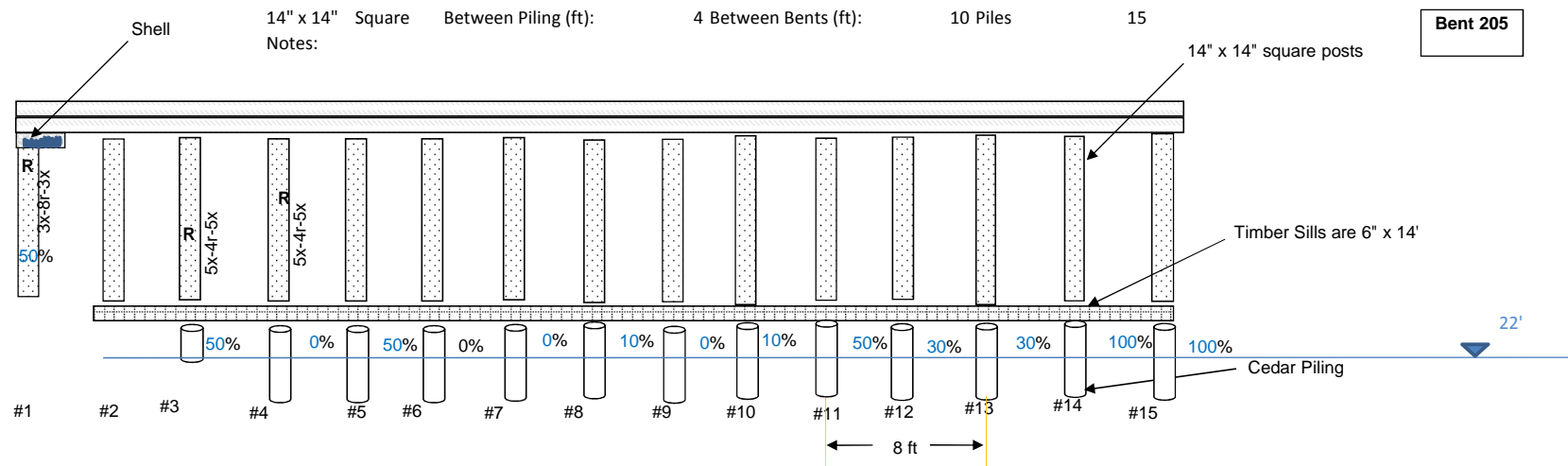

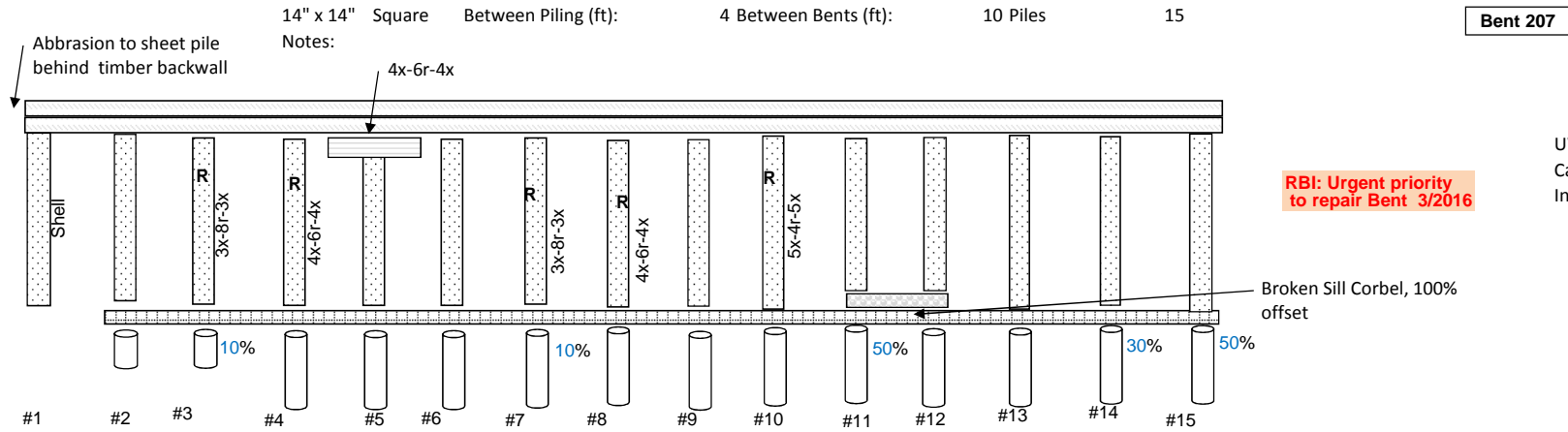

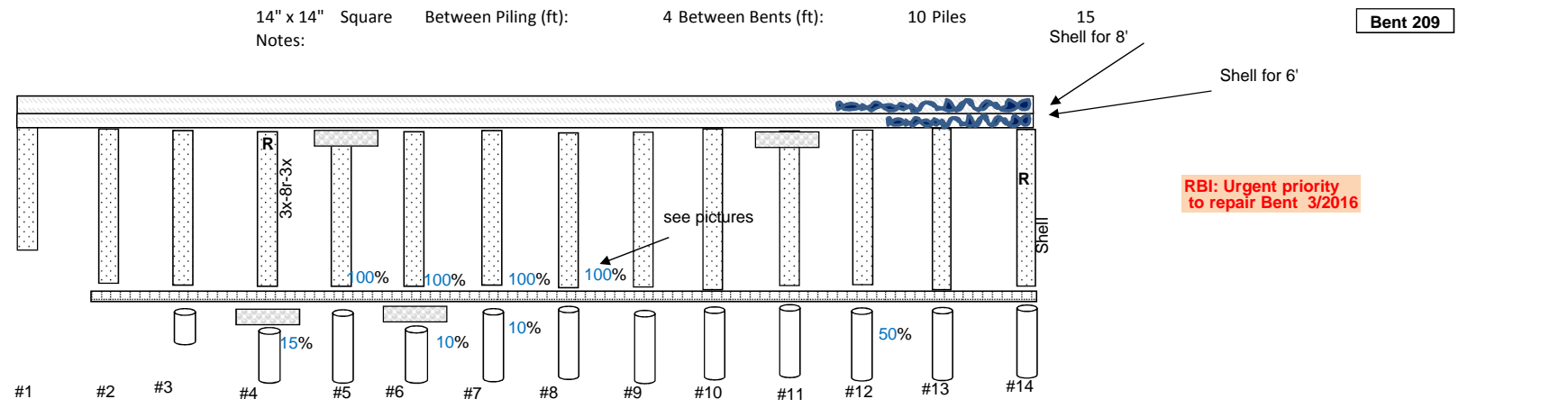
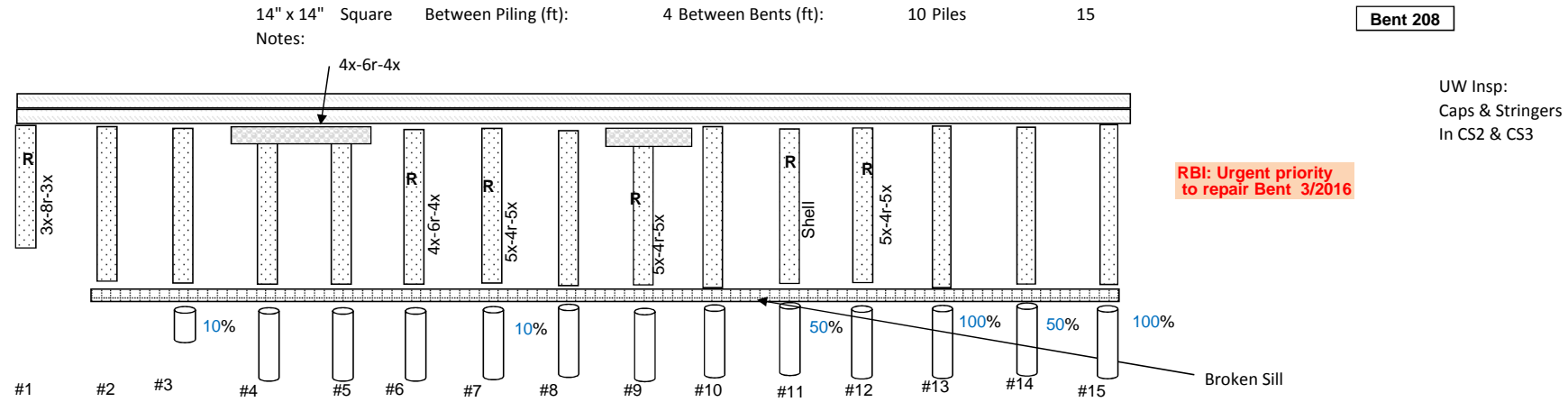

14" x 14" Square Between Piling (ft): 4 Between Bents (ft): 10 Piles 15
Notes:

Bent 210

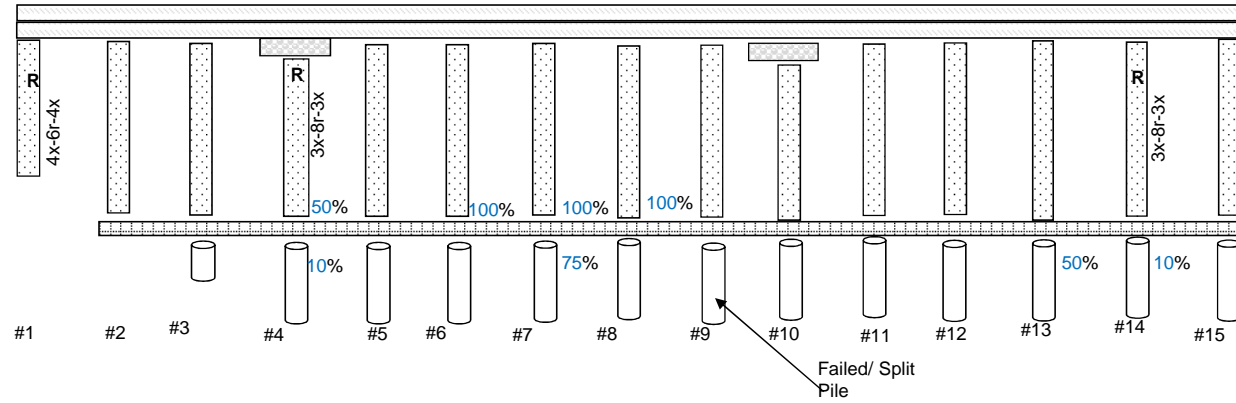

14" x 14" Square Between Piling (ft): 4 Between Bents (ft): 10 Piles 15
Notes:

Bent 211

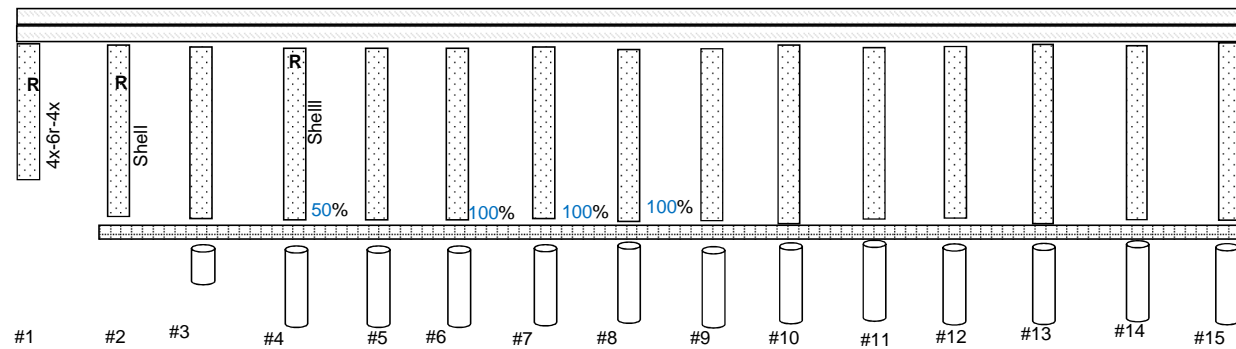

14" x 14" Square Between Piling (ft): 4 Between Bents (ft): 10 Piles 15
 Notes:

Bent 212

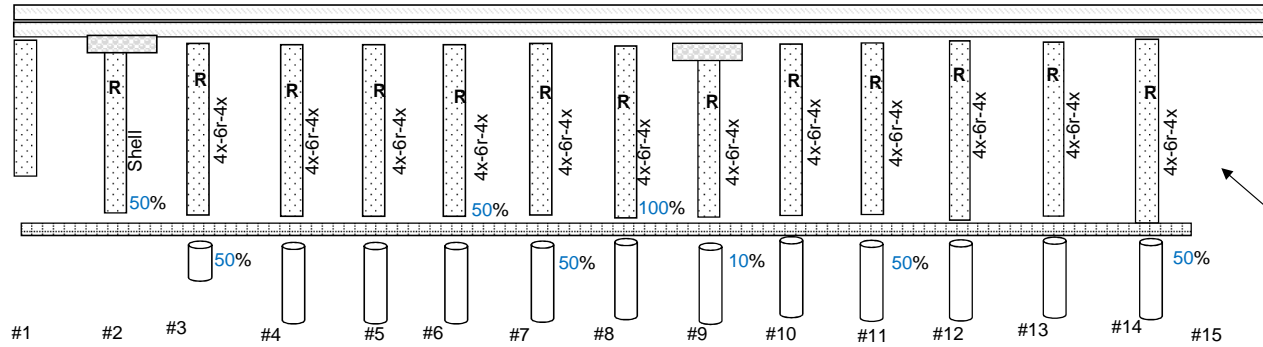

RBI: Urgent priority to repair Bent 3/2016

Missing pile & column

14" x 14" Square Between Piling (ft): 4 Between Bents (ft): 10 Piles 15
 Notes:

Bent 213

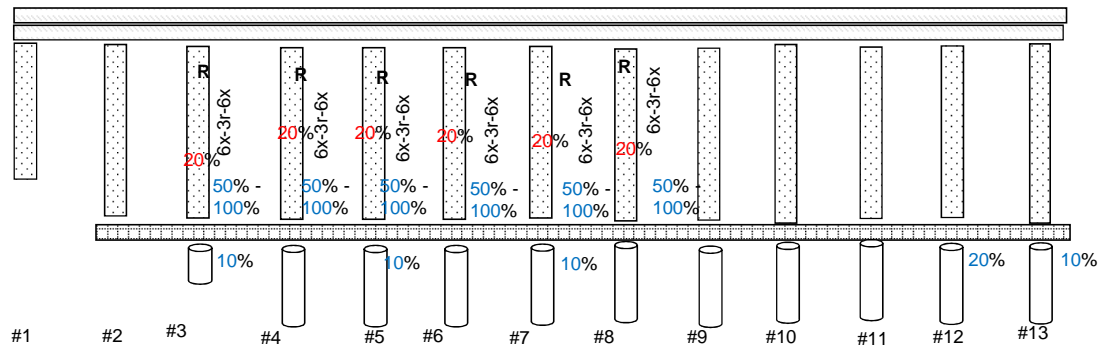

RBI: Urgent priority to repair Bent 3/2016

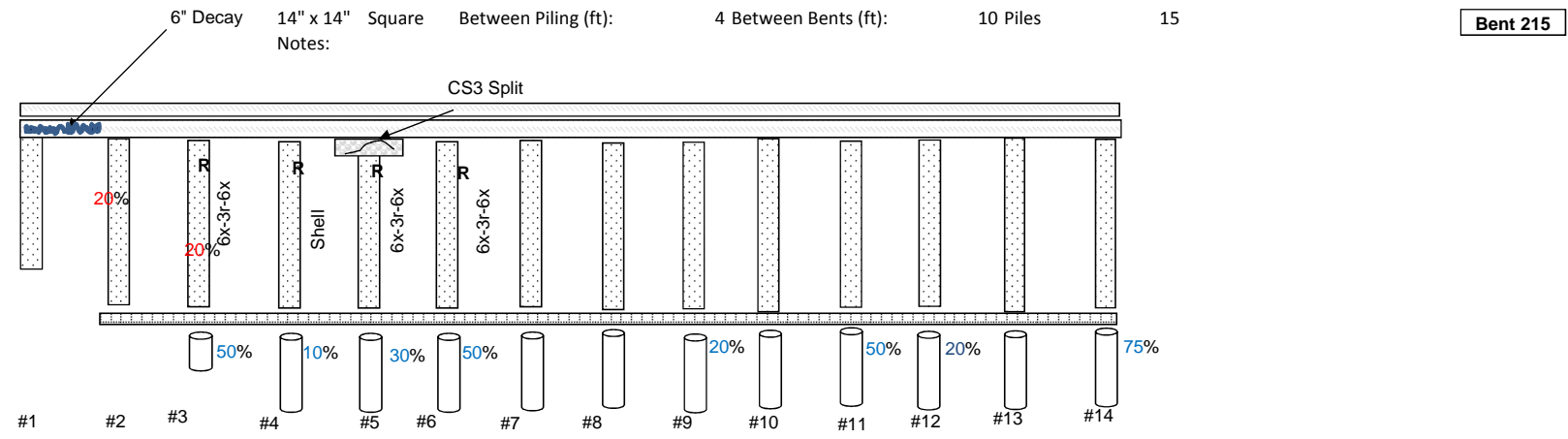
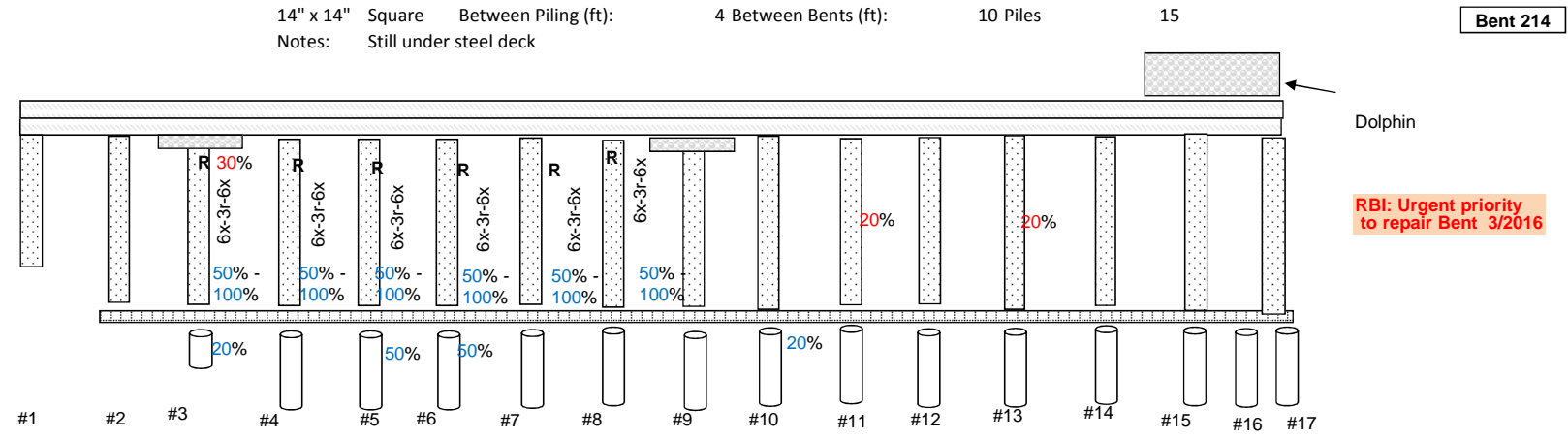

14" x 14" Square Between Piling (ft): 4 Between Bents (ft): 10 Piles 15
 Notes: 6" Decay

Bent 216

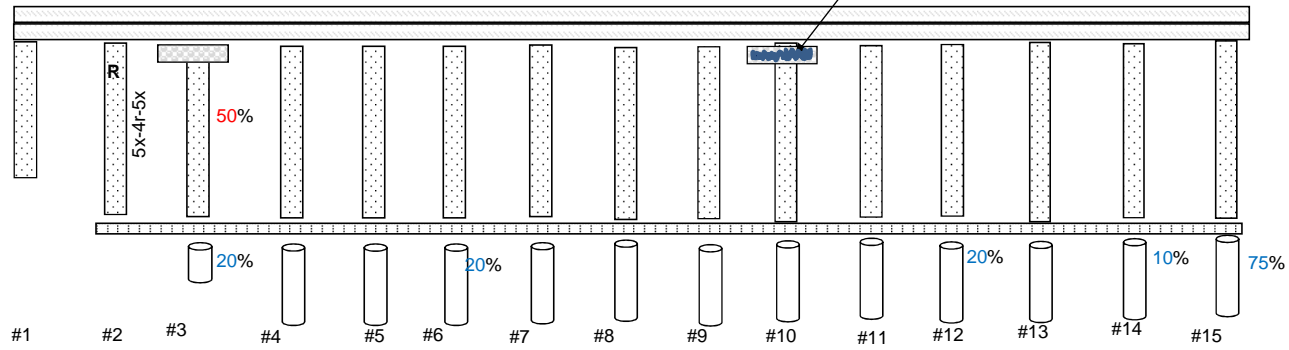

14" x 14" Square Between Piling (ft): 4 Between Bents (ft): 10 Piles 15
 Notes:

Bent 217

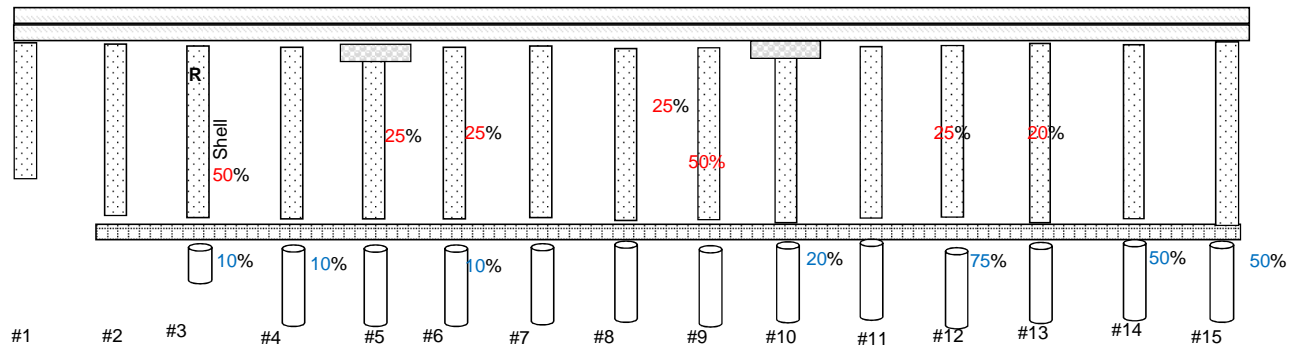

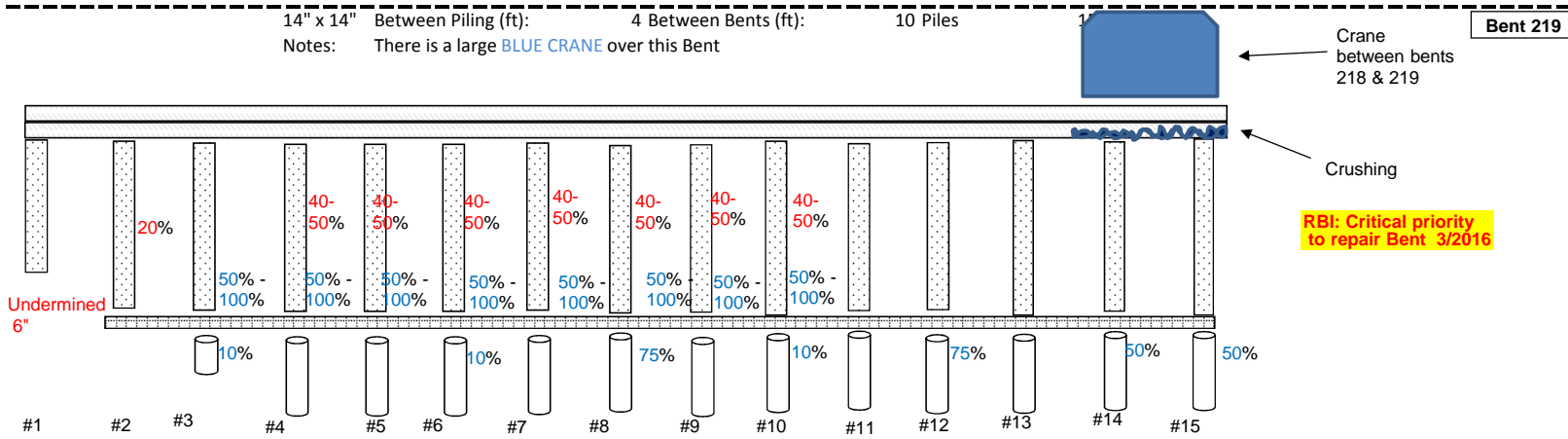
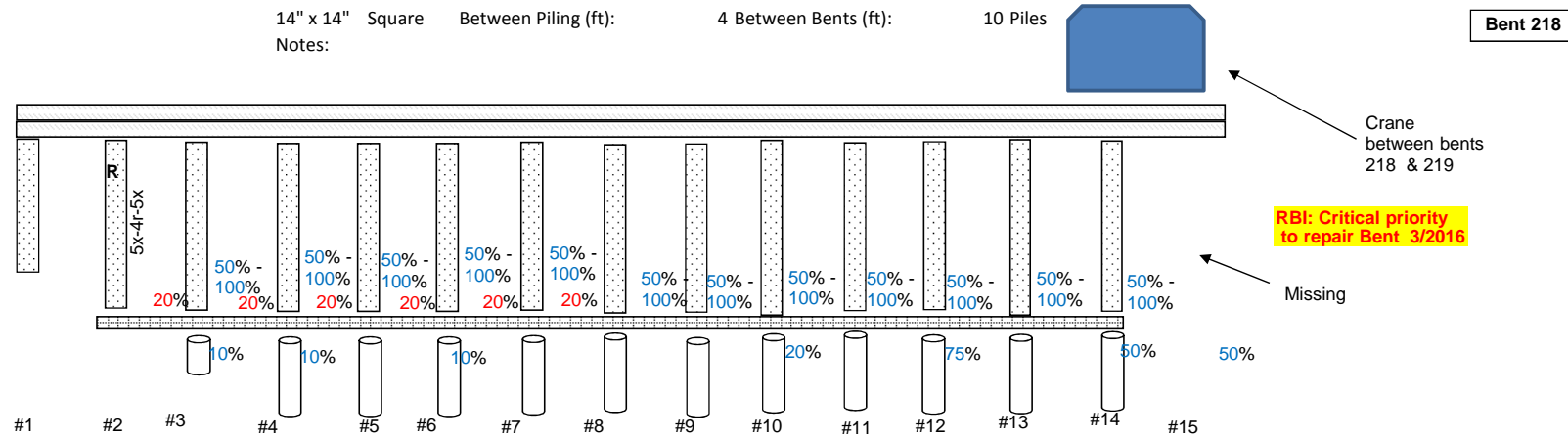

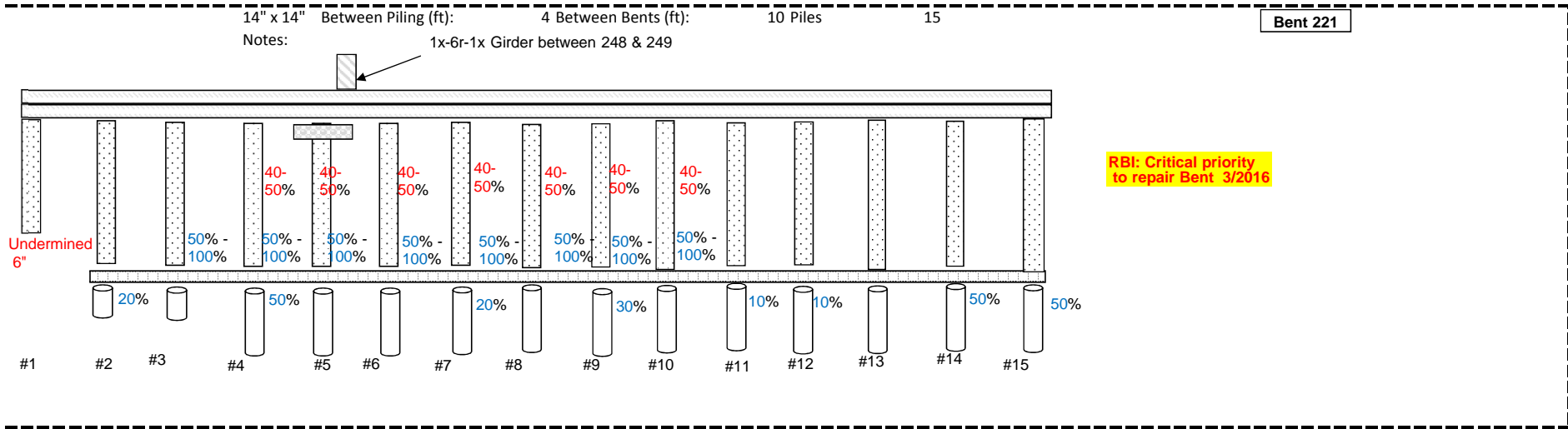
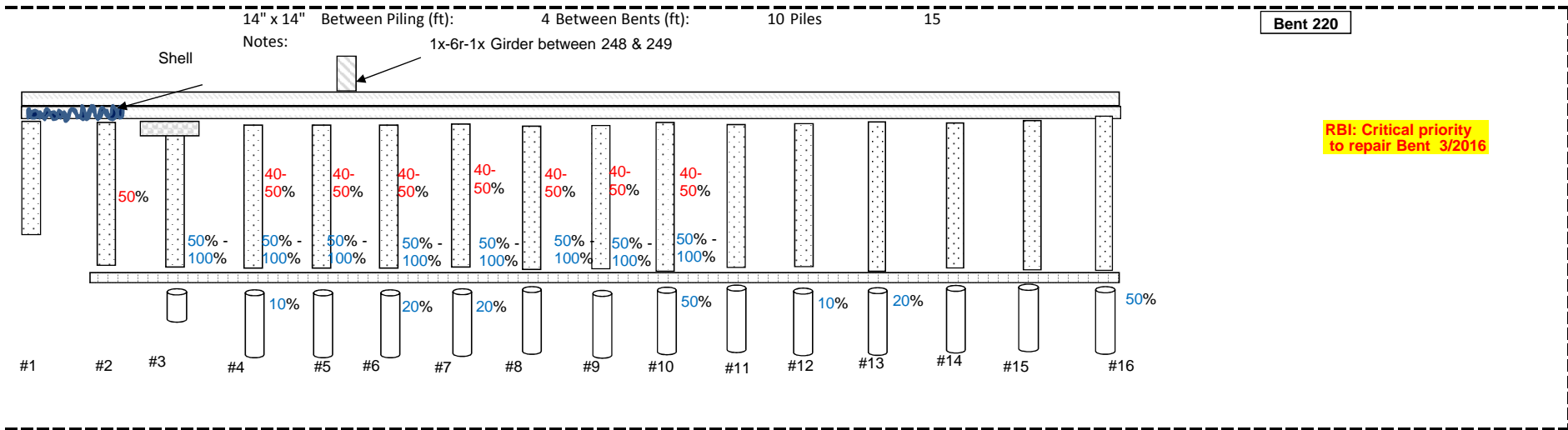

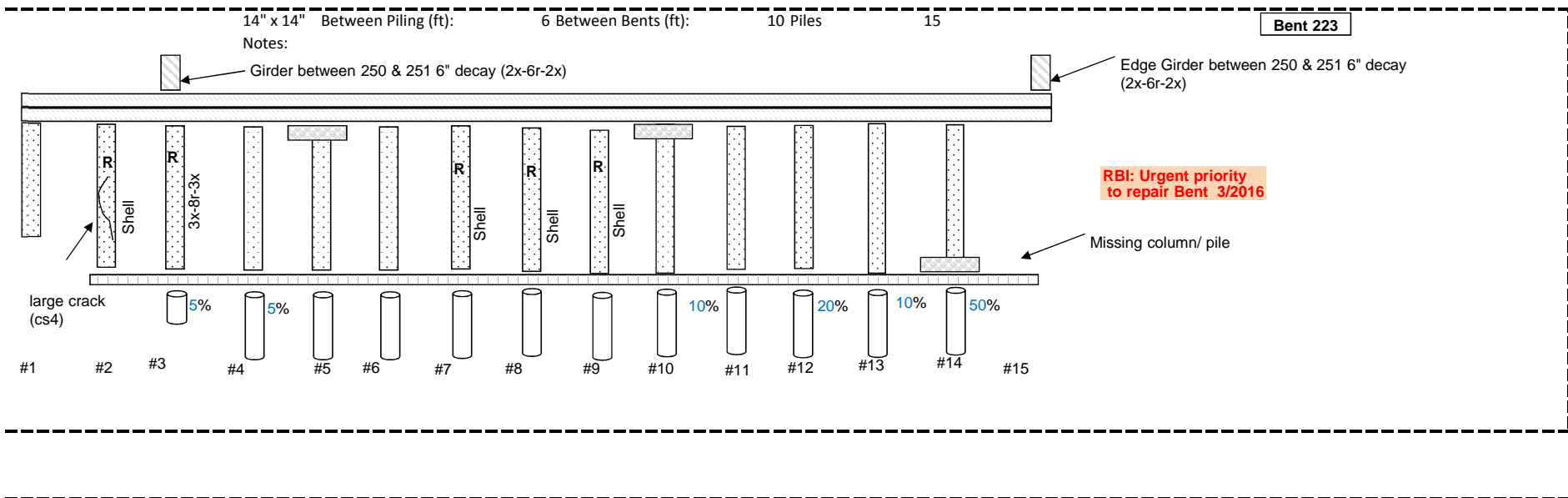
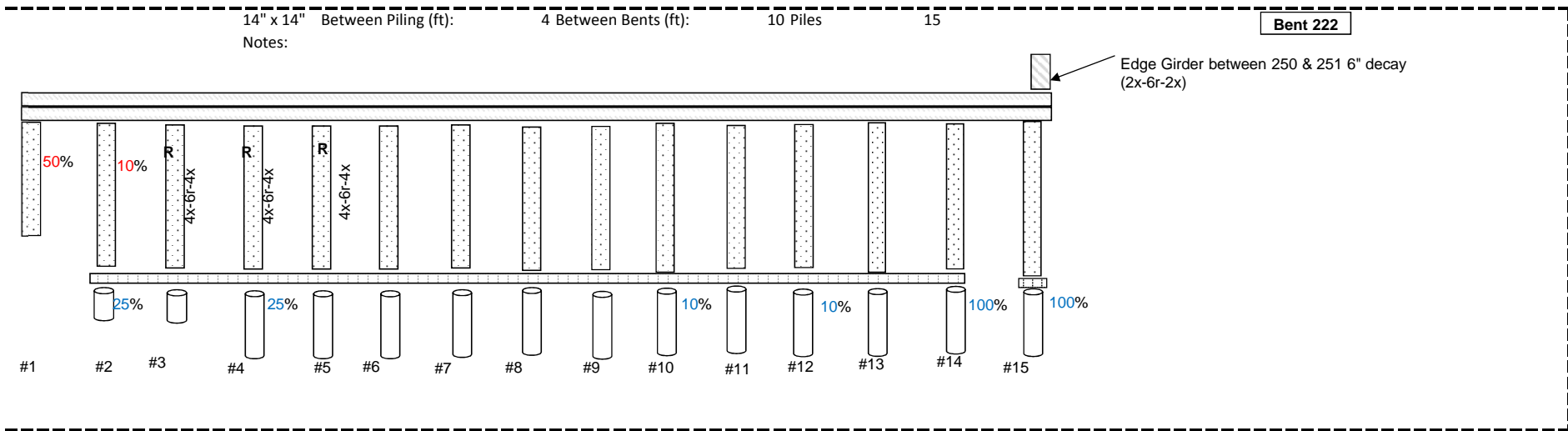

14" x 14" Between Piling (ft):
Notes:

4 Between Bents (ft):

10 Piles

15

Bent 224

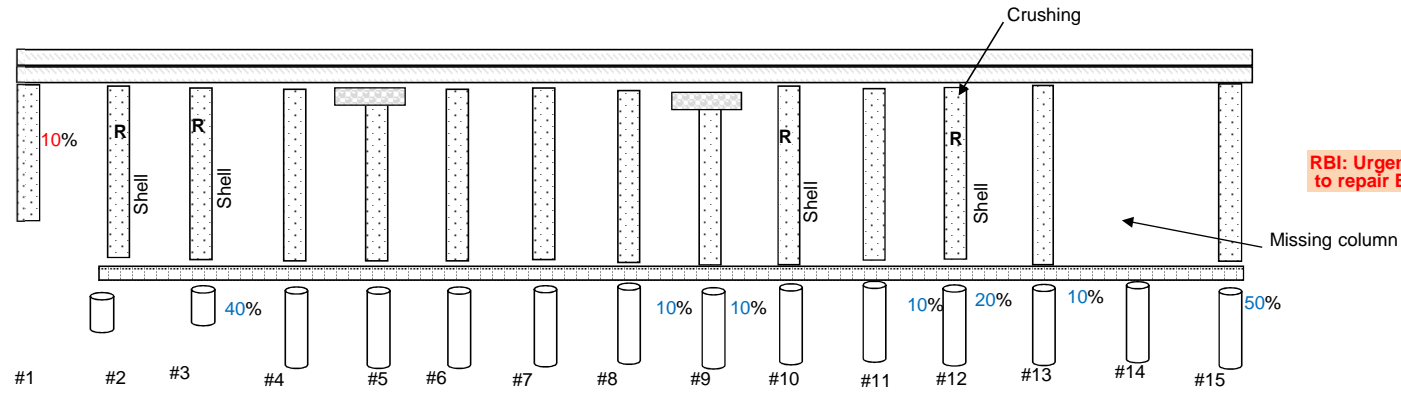

14" x 14" Between Piling (ft):
Notes:

4 Between Bents (ft):

10 Piles

15

Bent 225

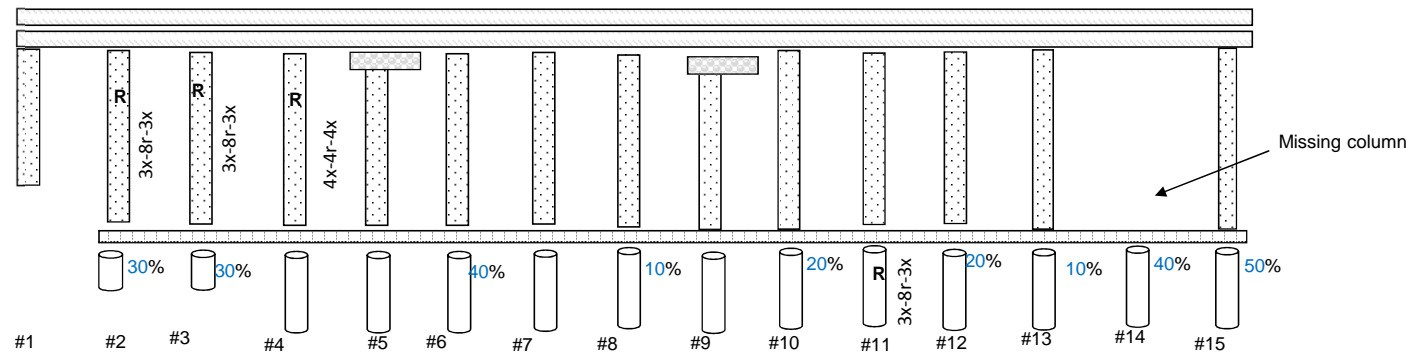

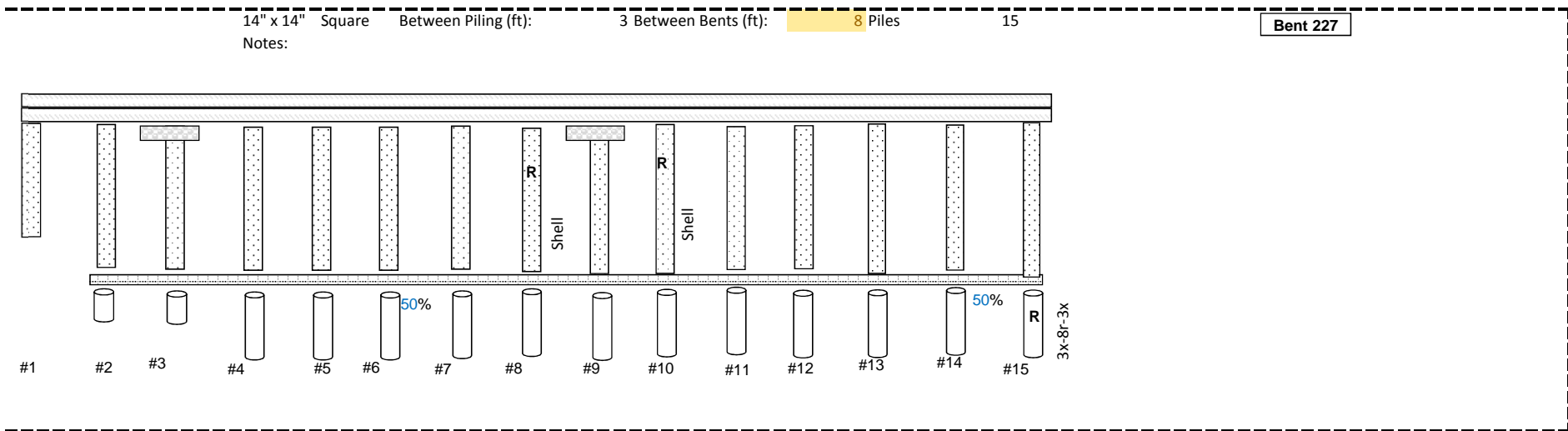
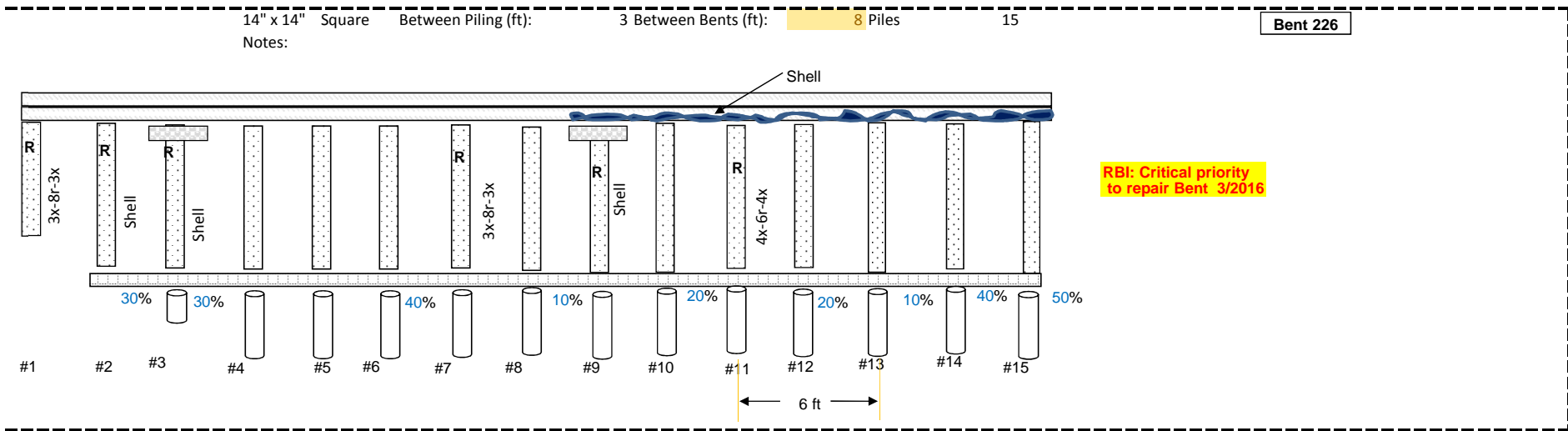

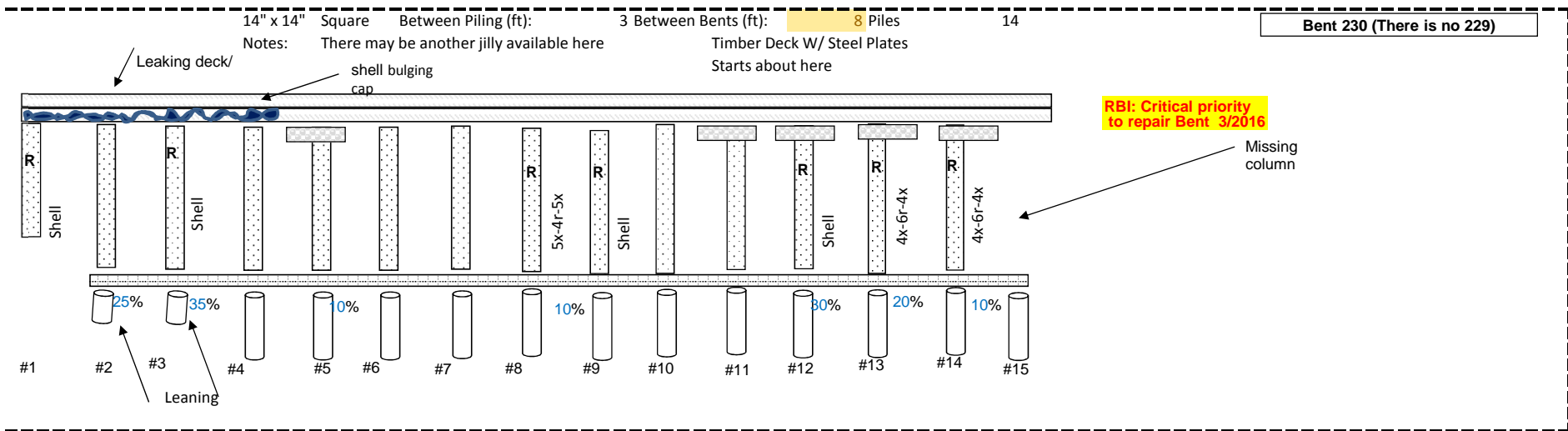
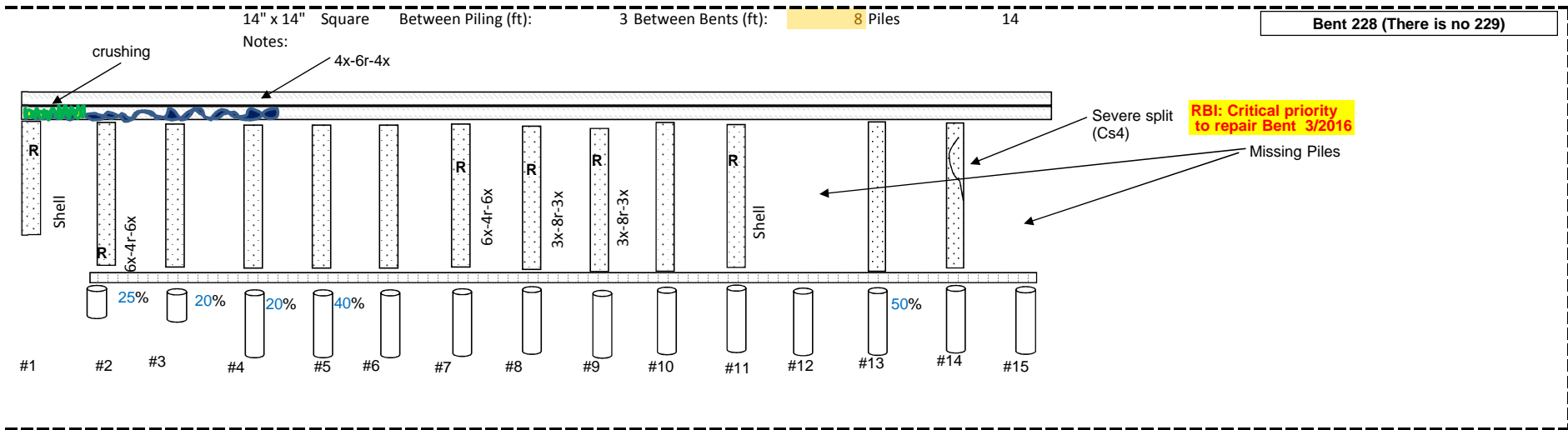

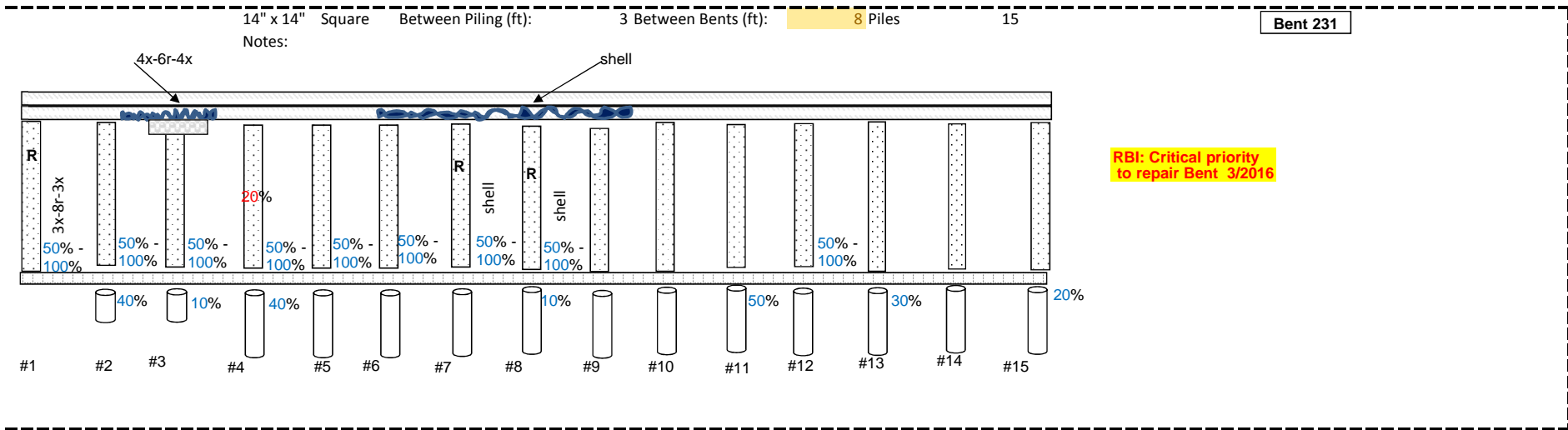

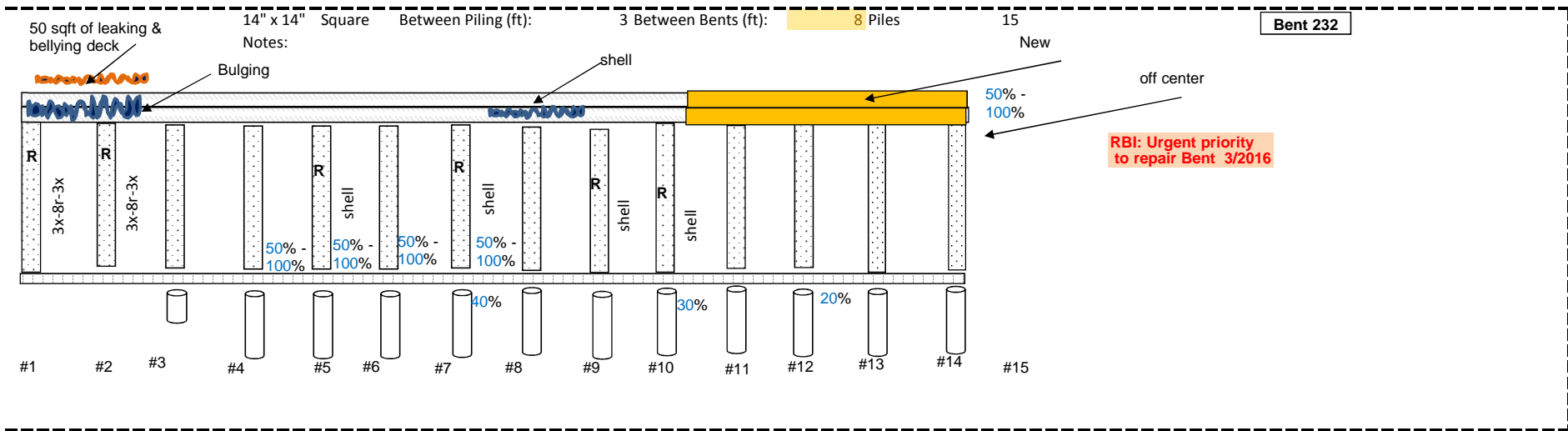

Note that Bents numbered on the site as 202-229 are just the other end of bents 201 to 189. See figure

Need to update water depths 9/15/2016

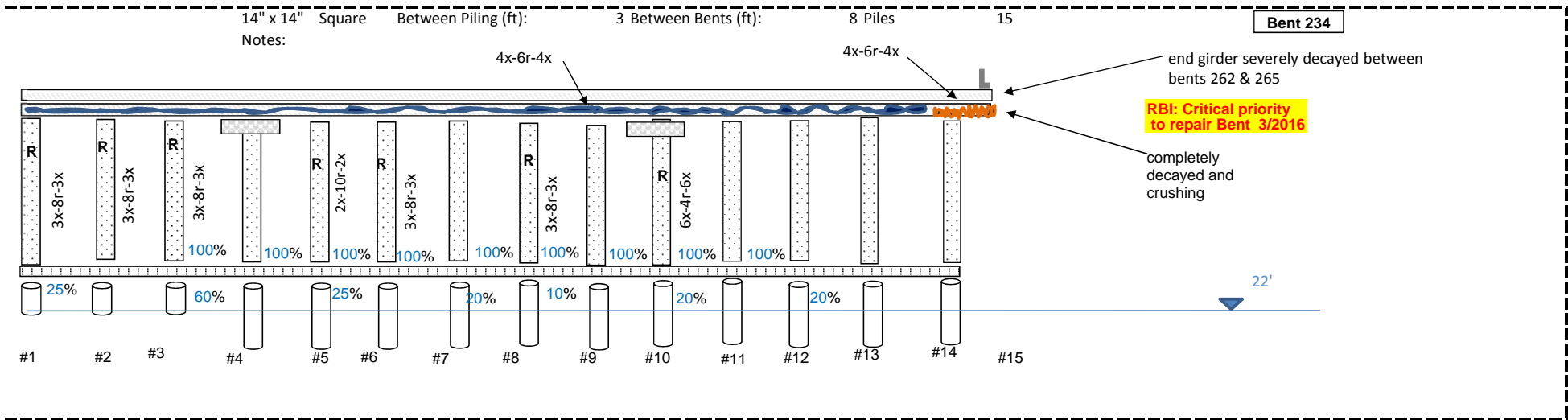
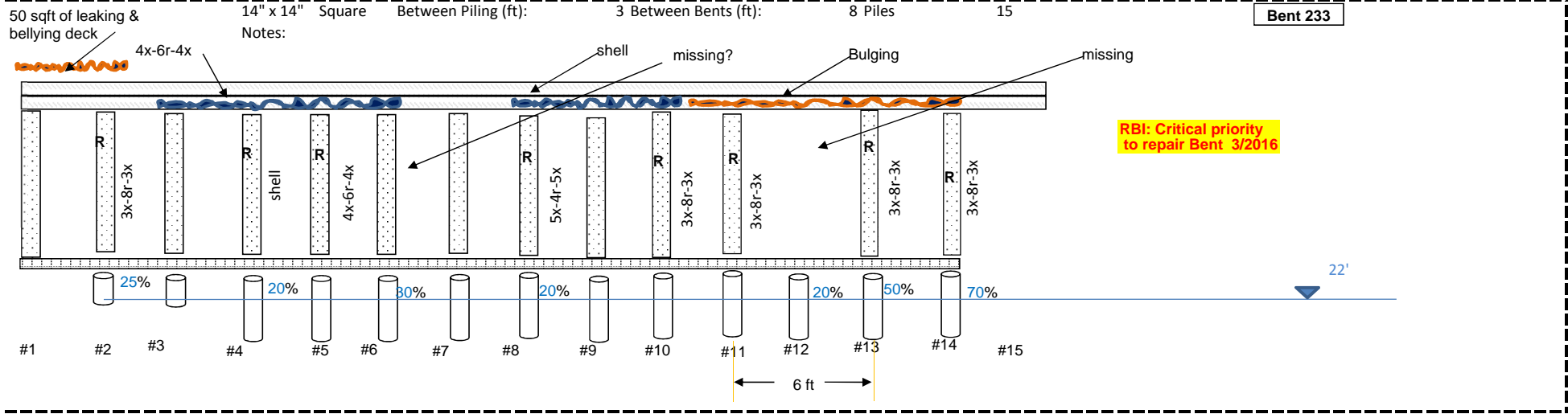

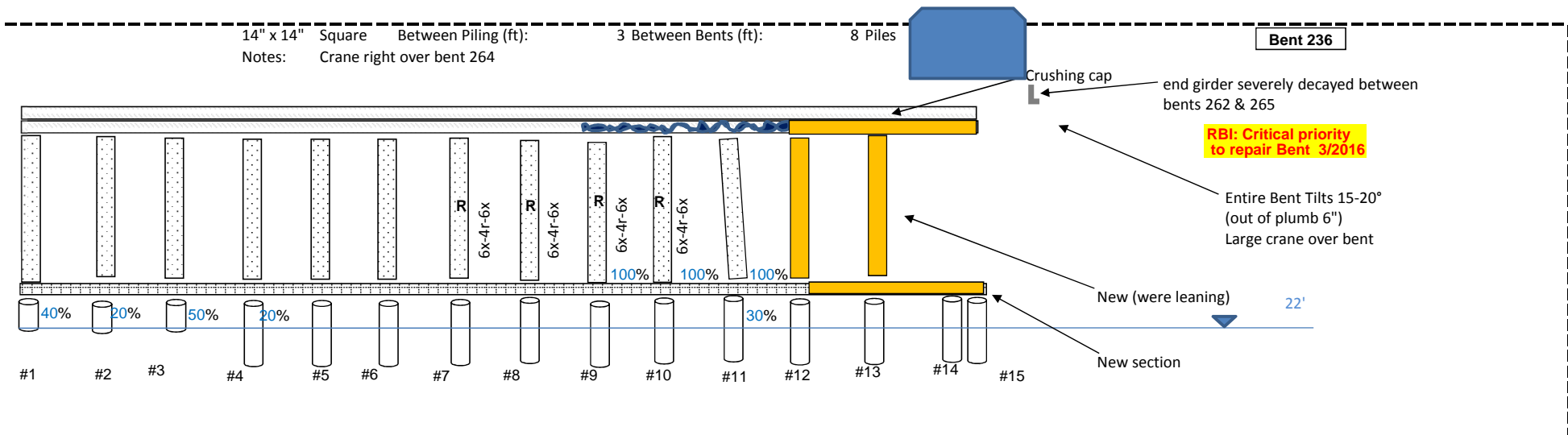
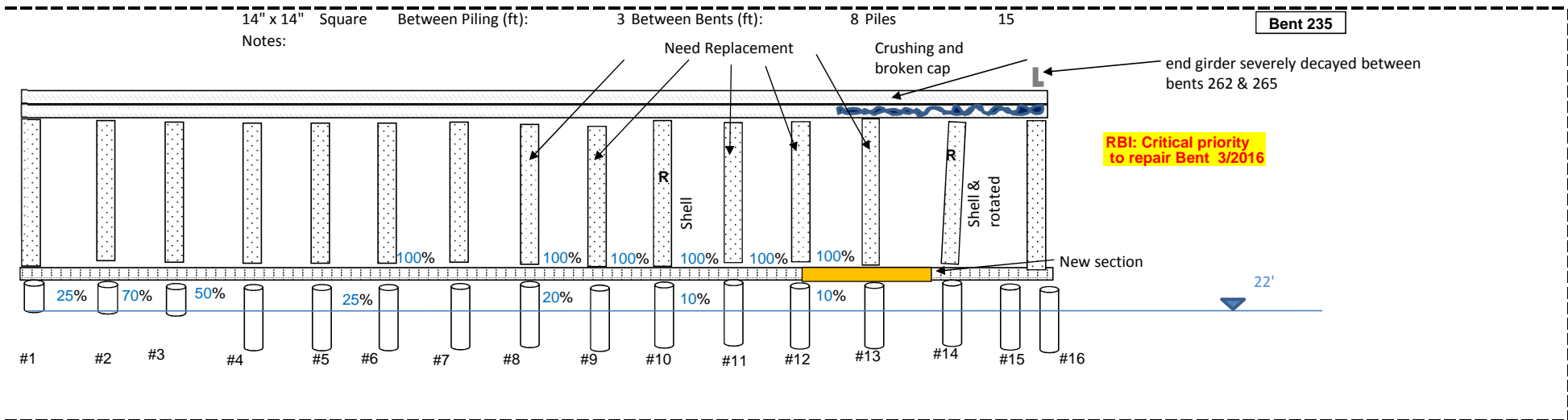

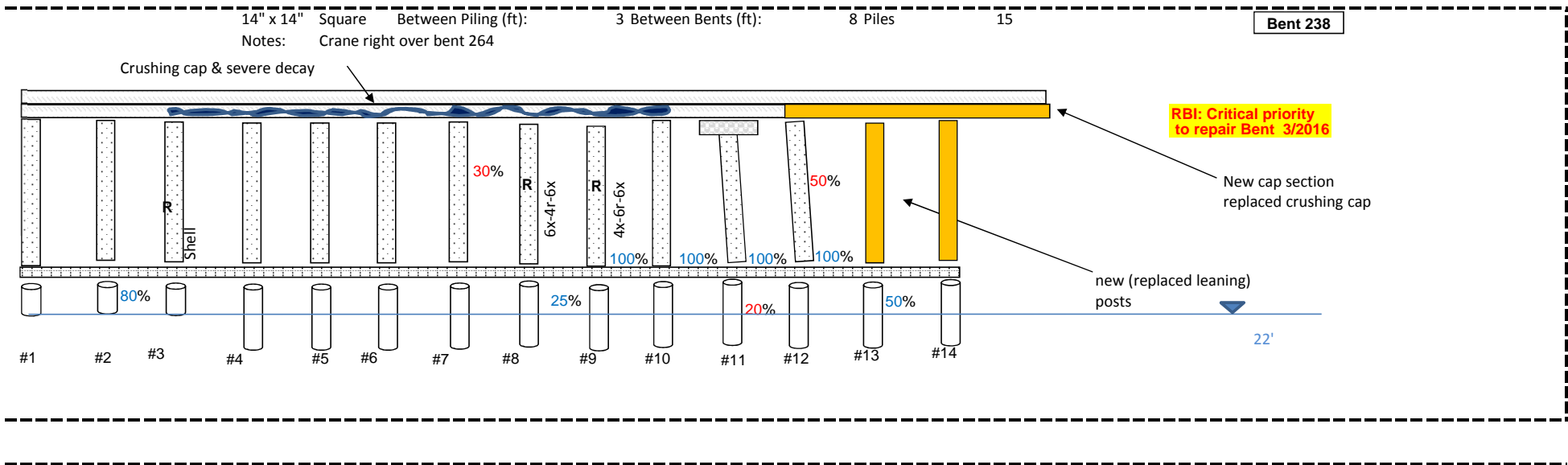
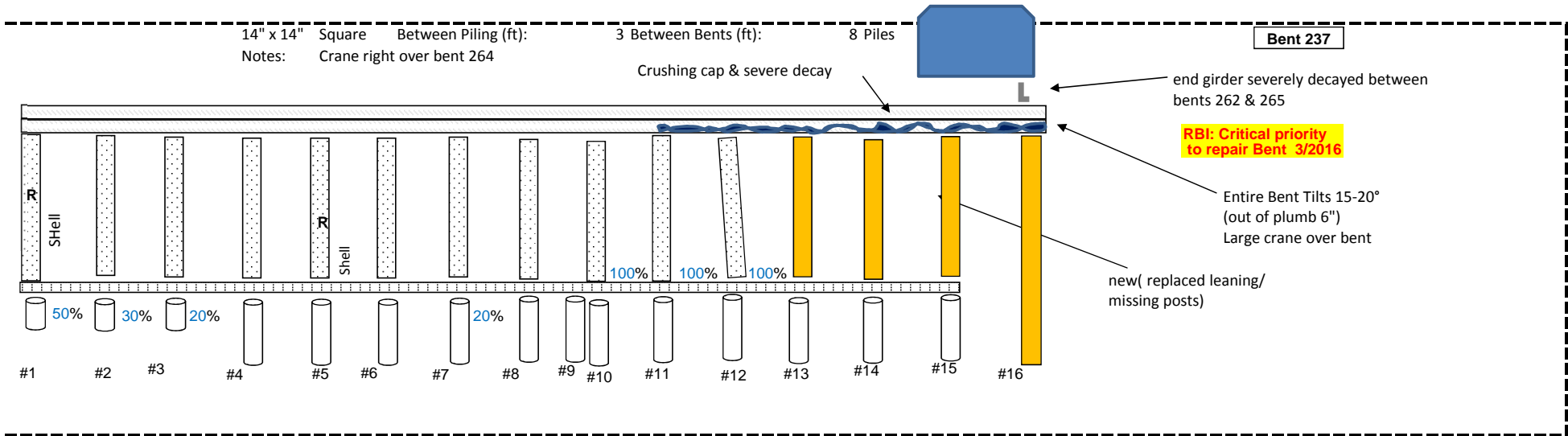

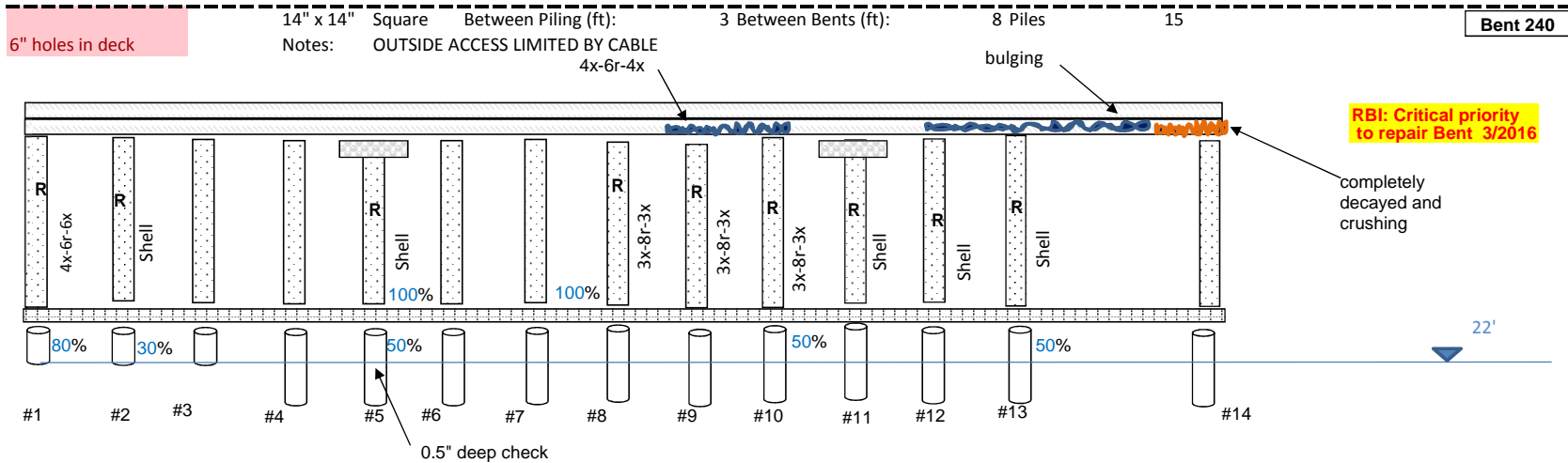
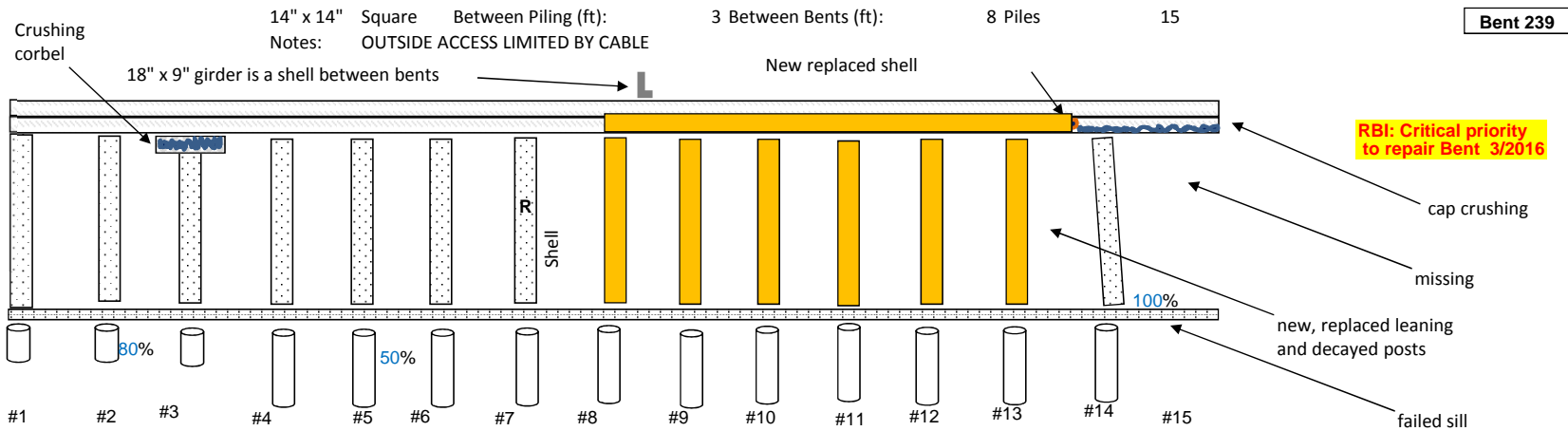

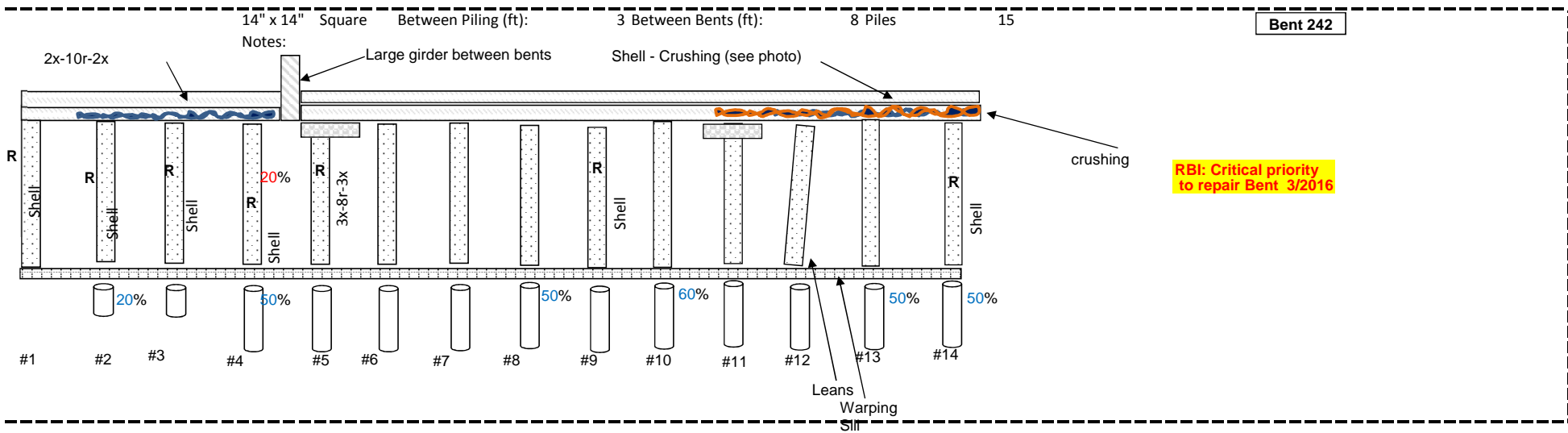
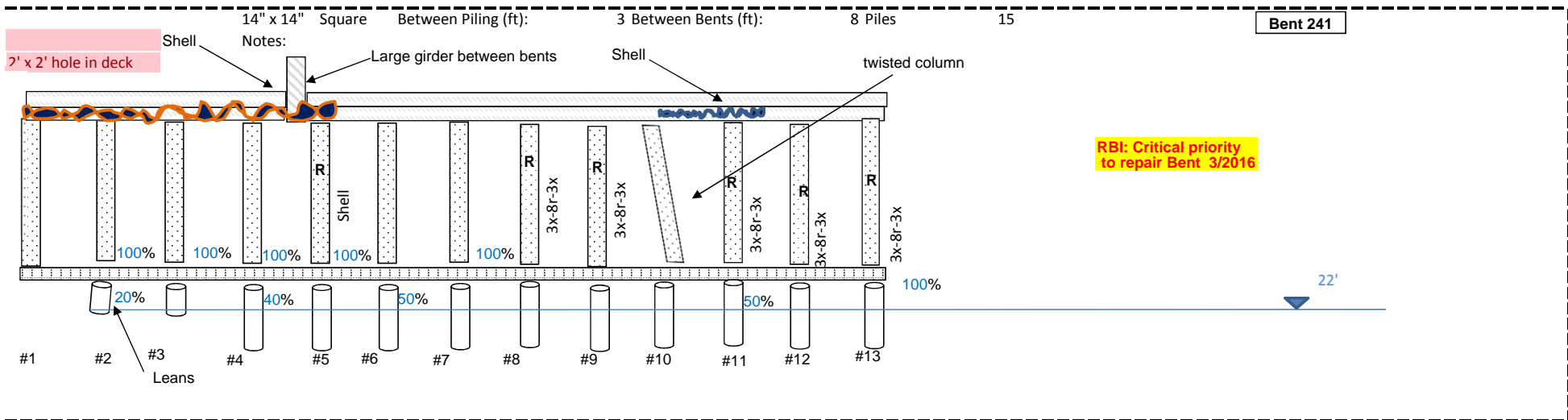

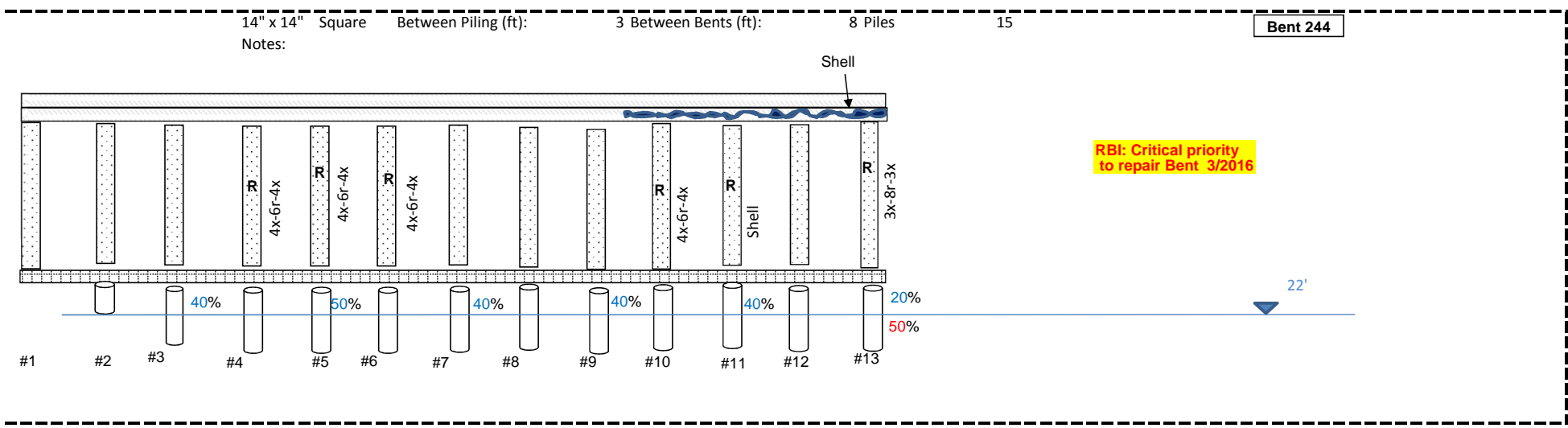
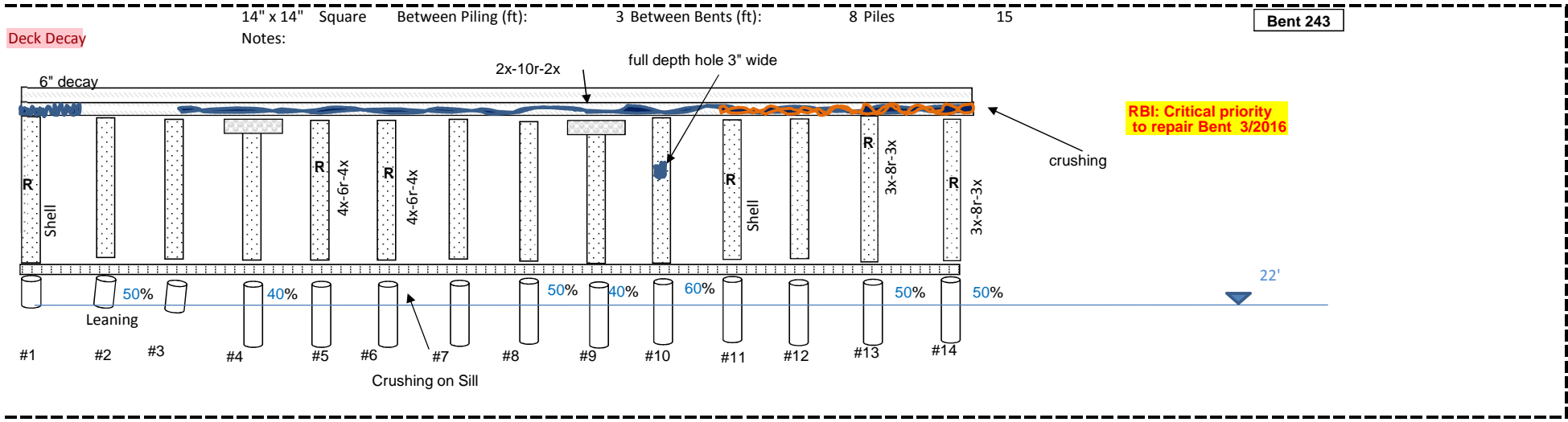

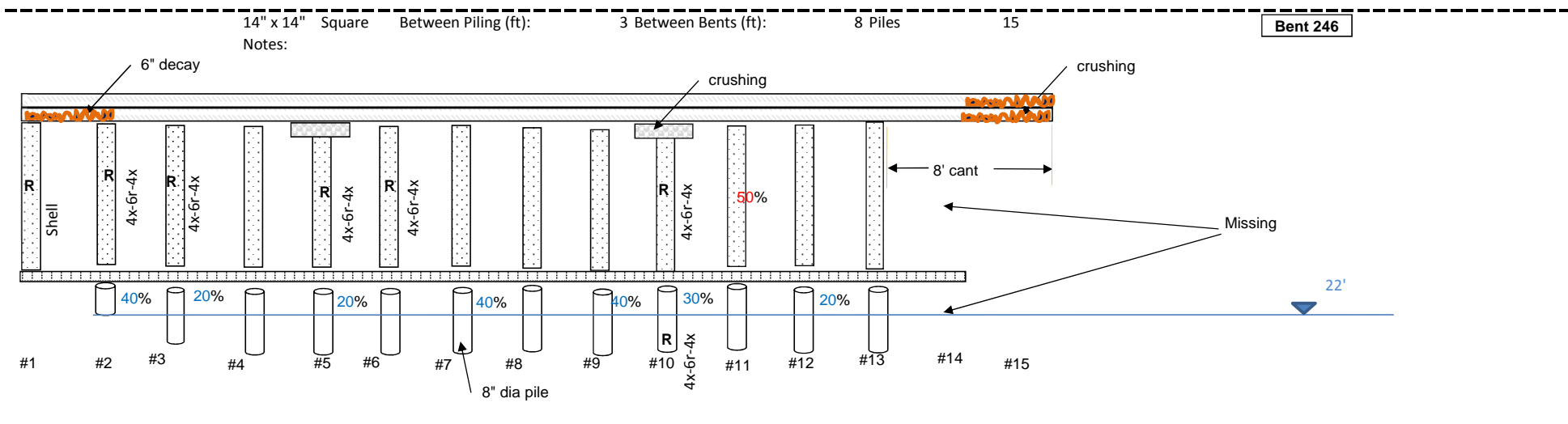
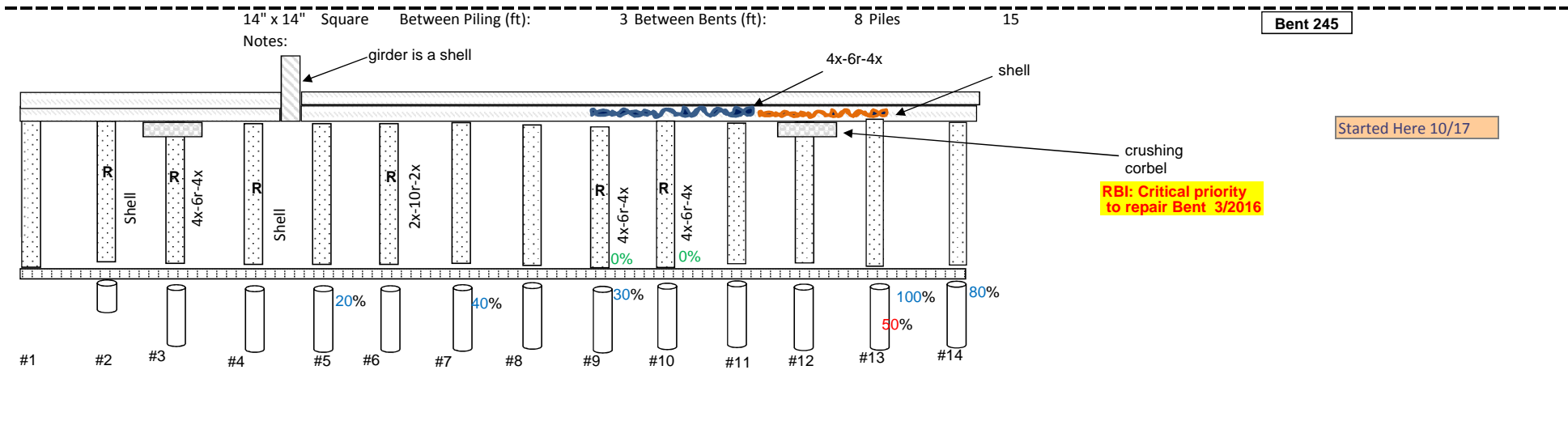

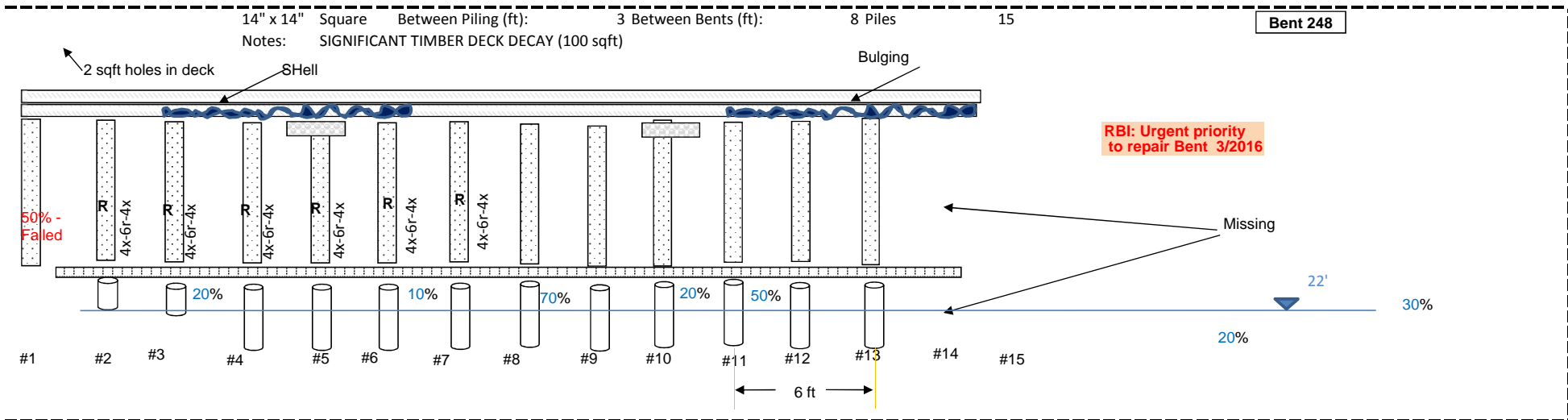
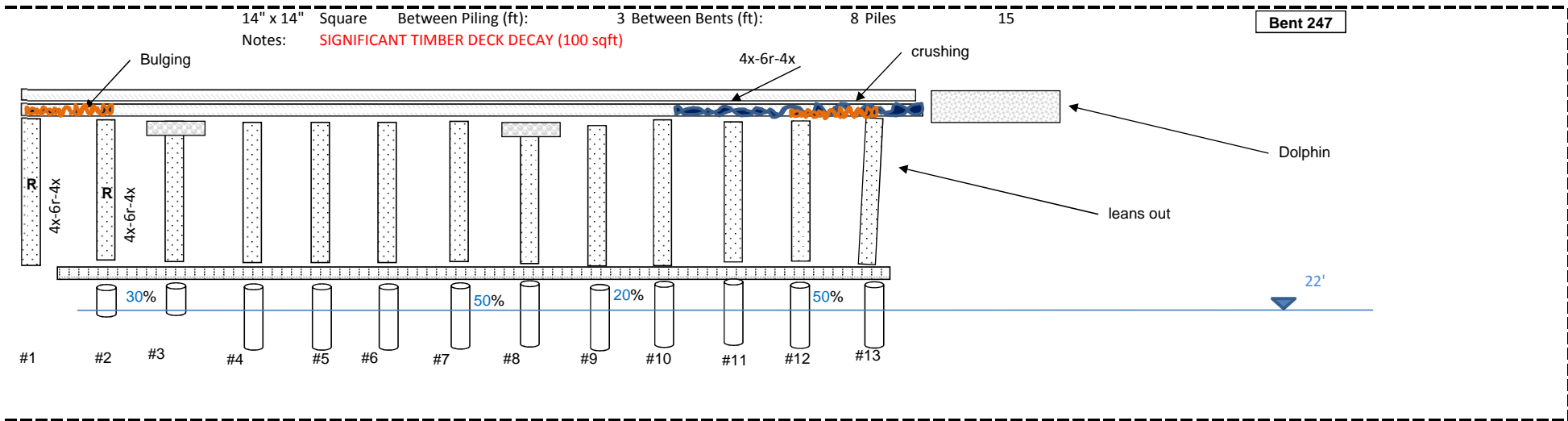

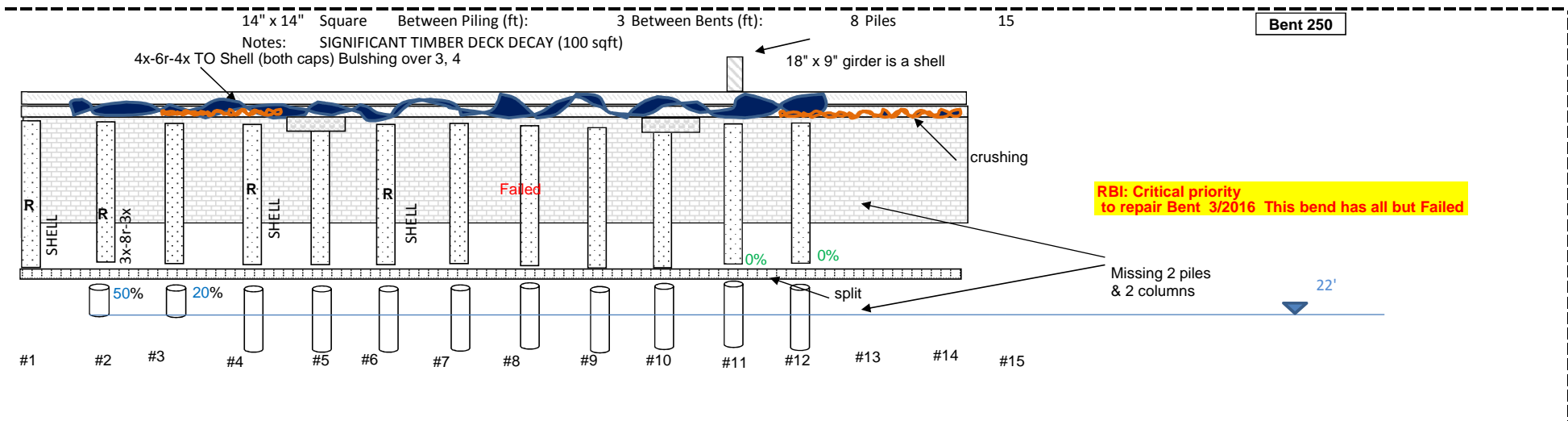
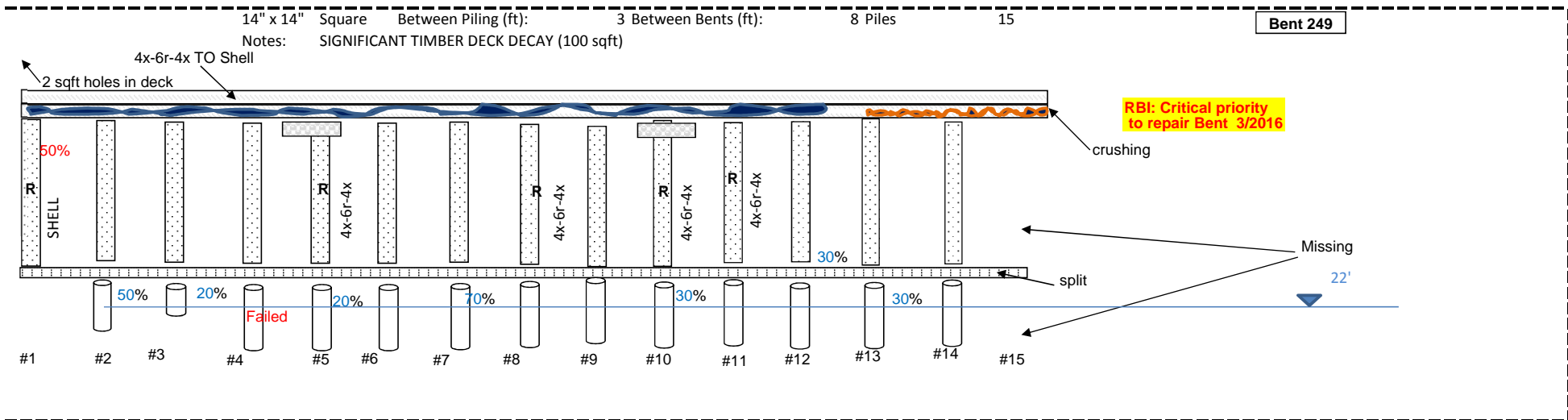

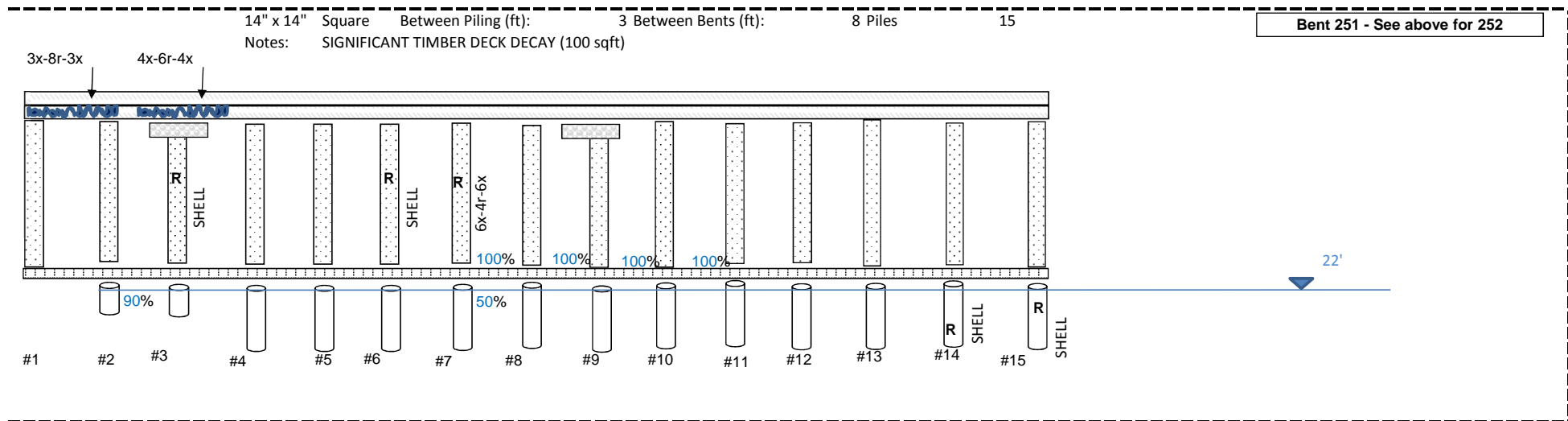
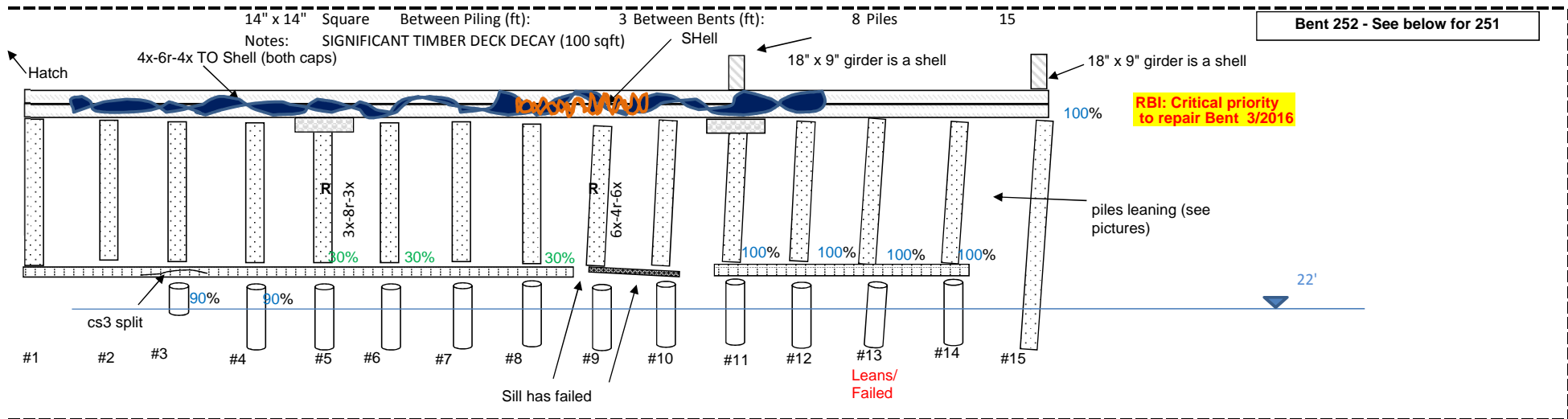

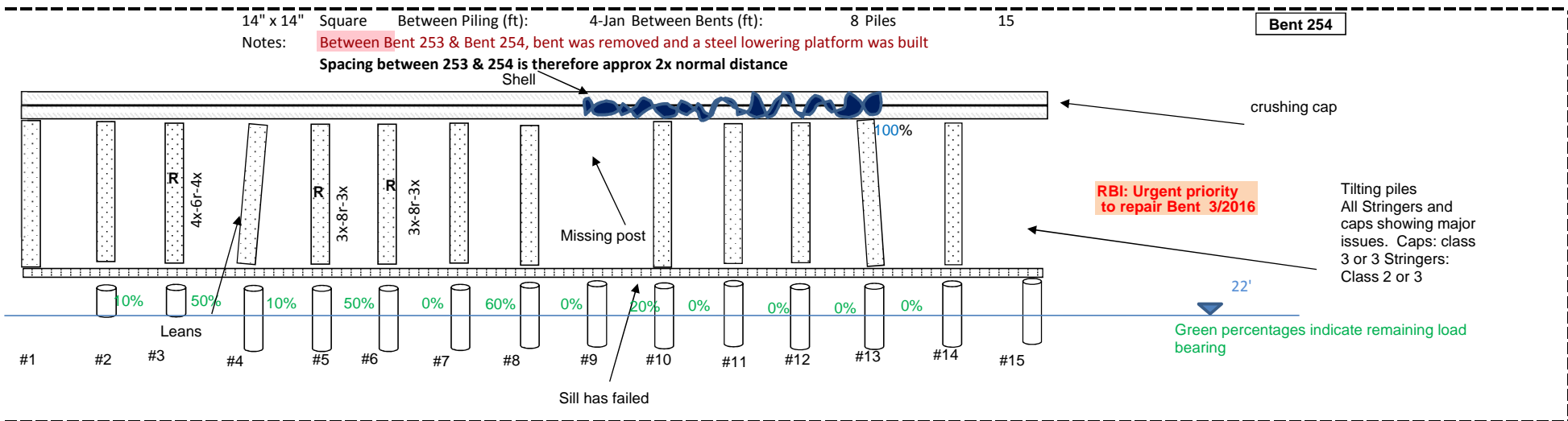
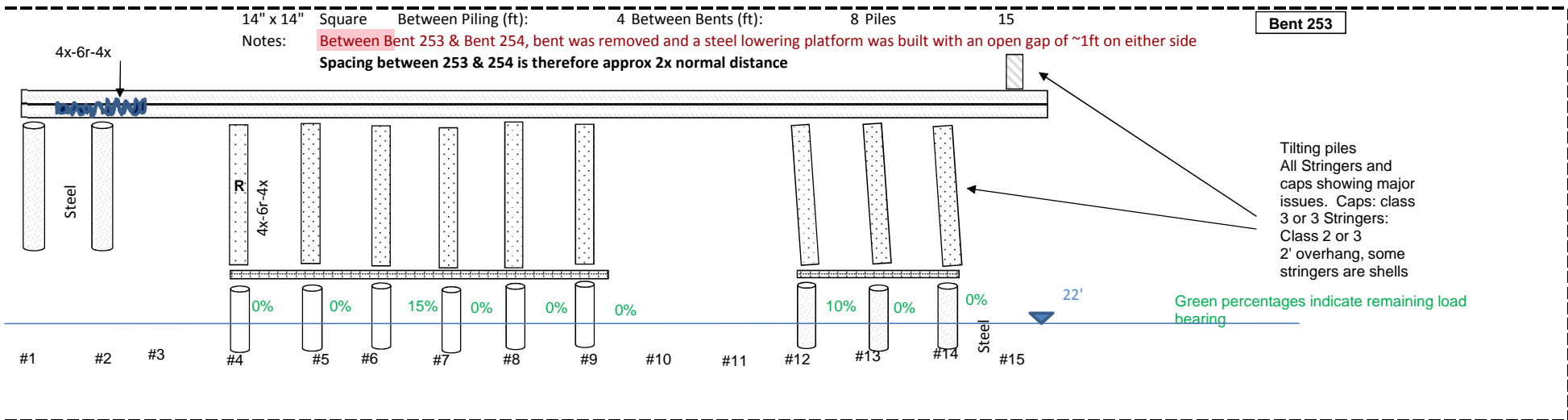

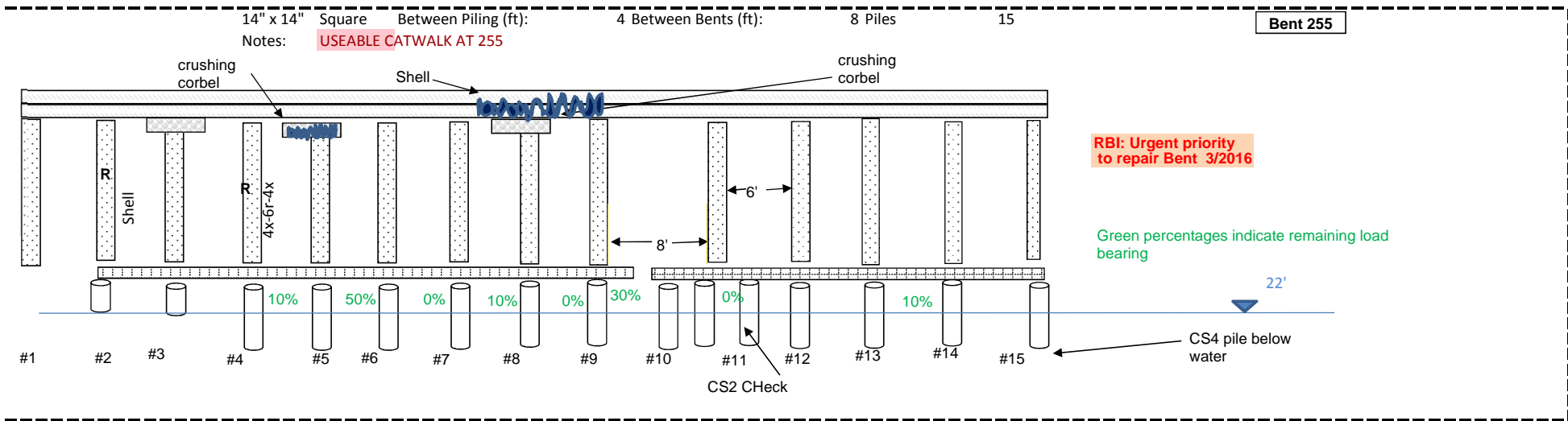

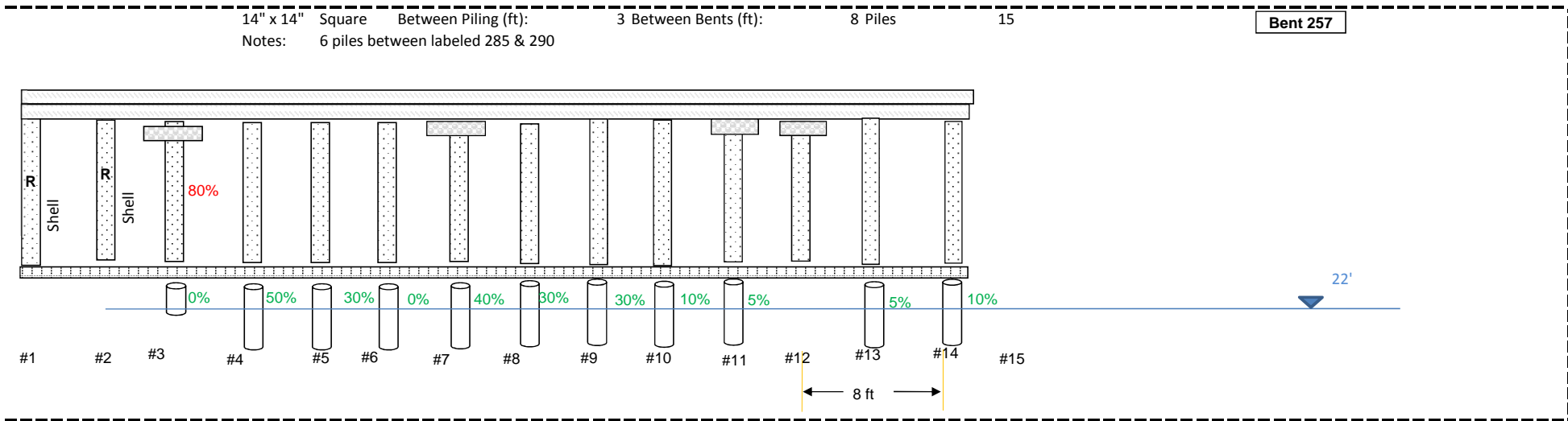
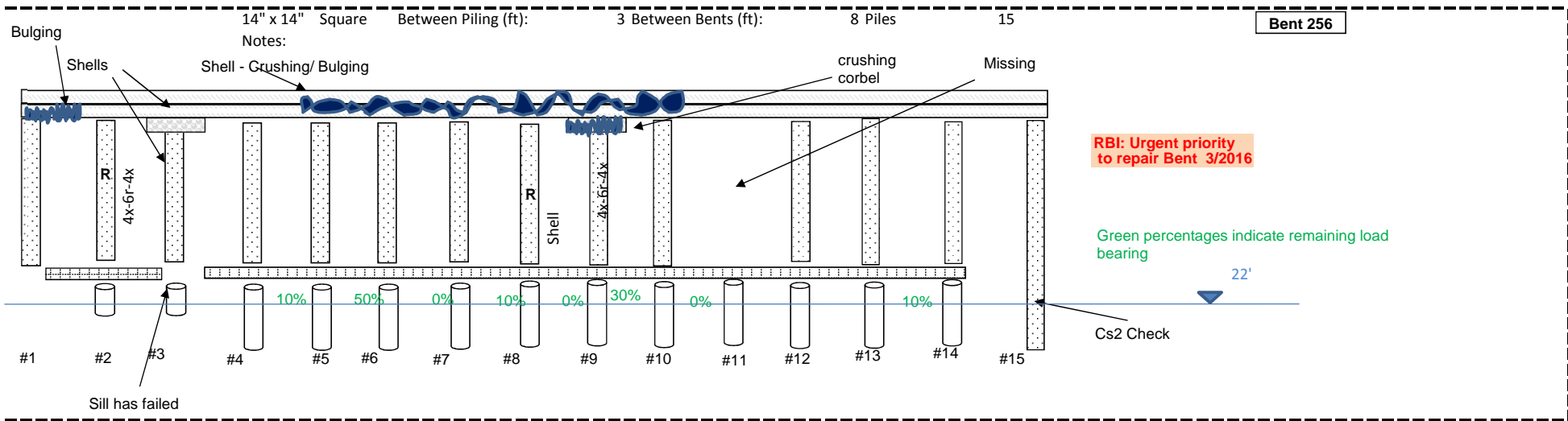

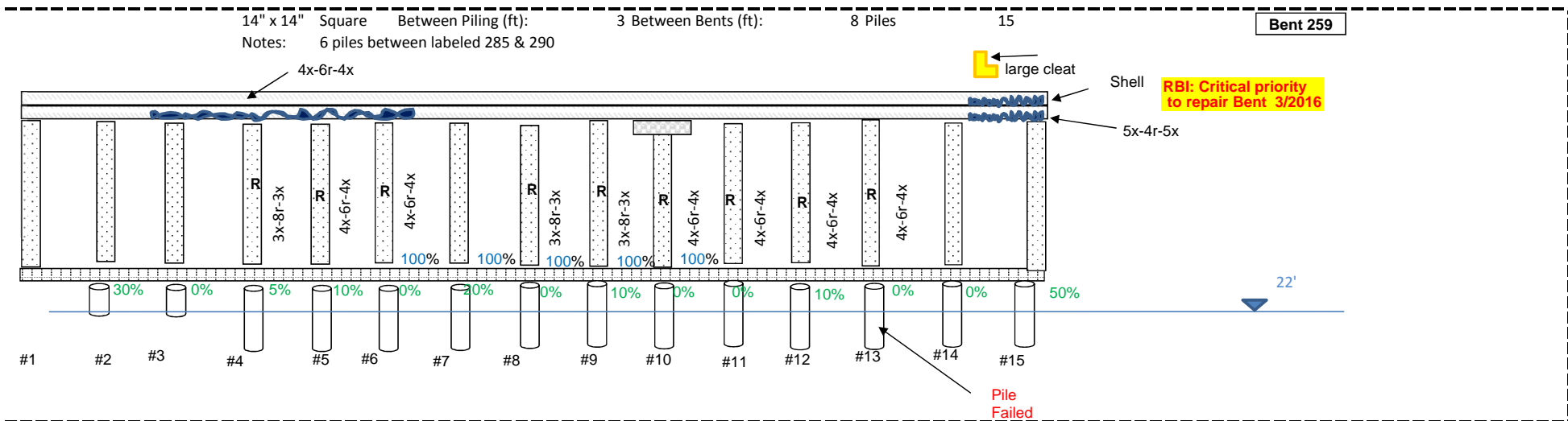
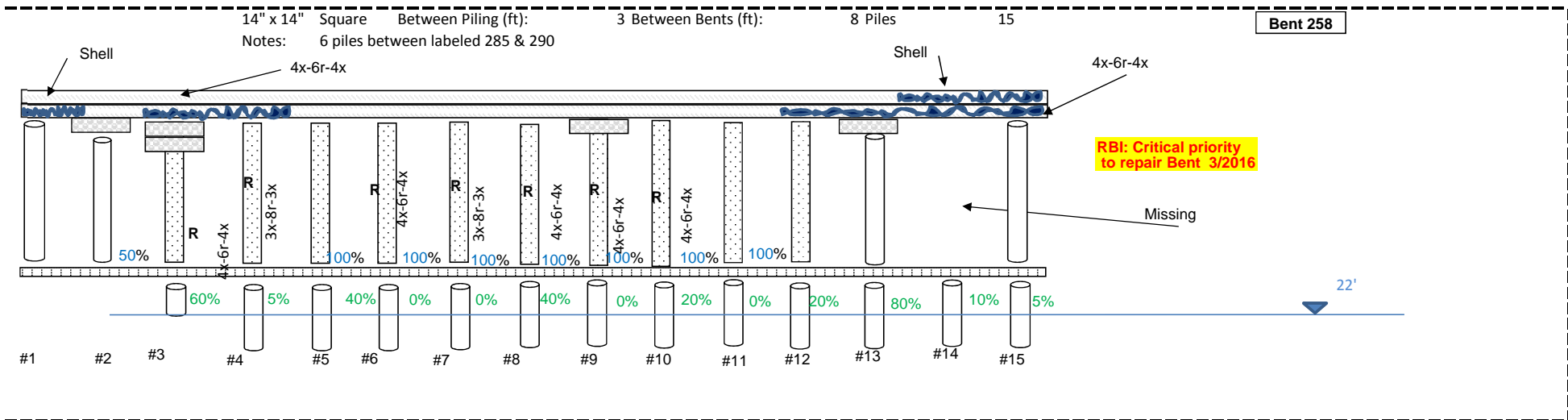

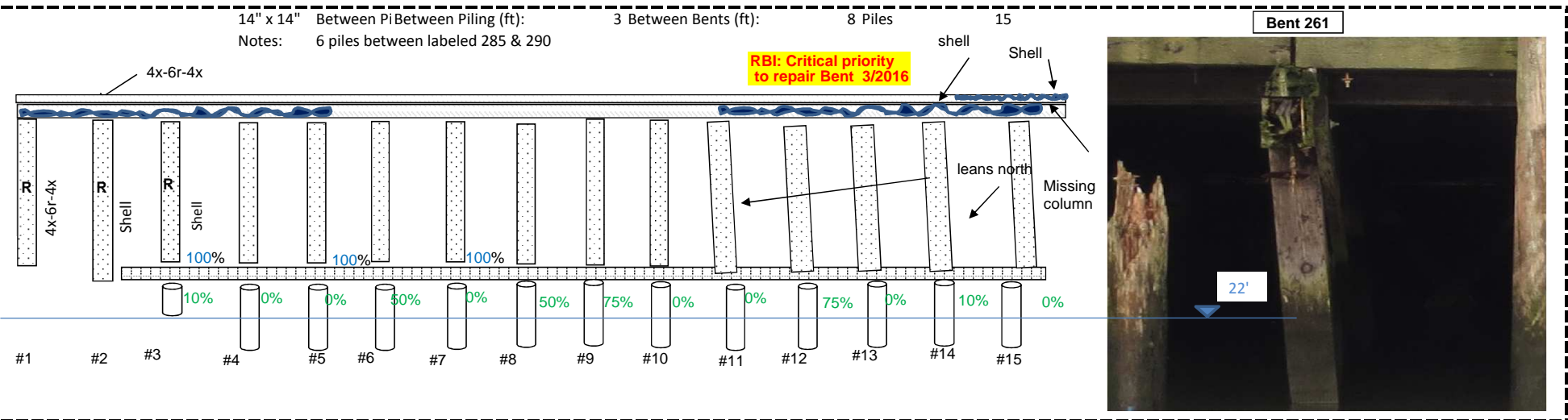
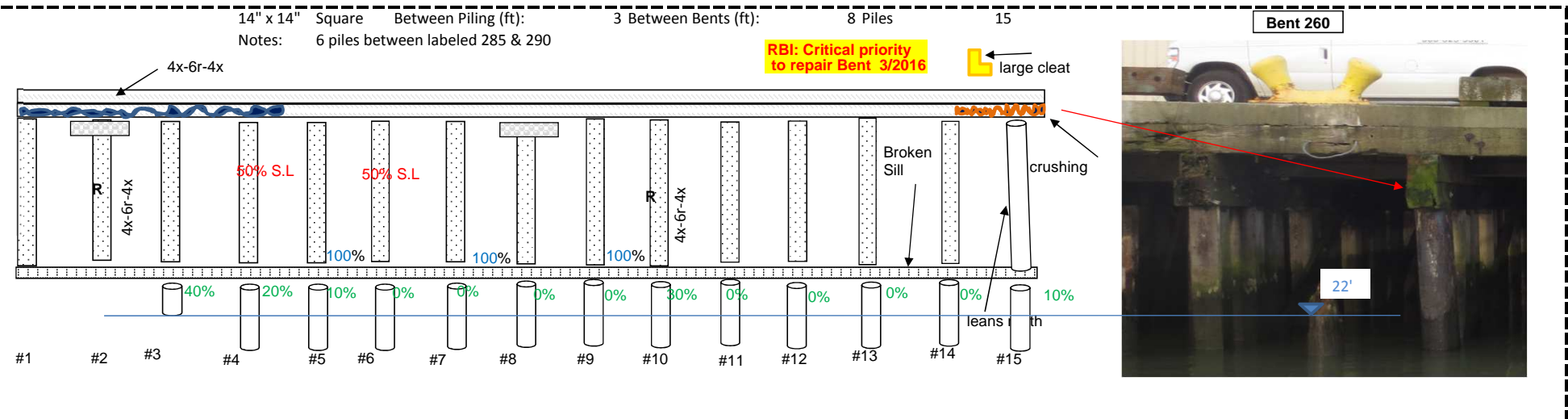

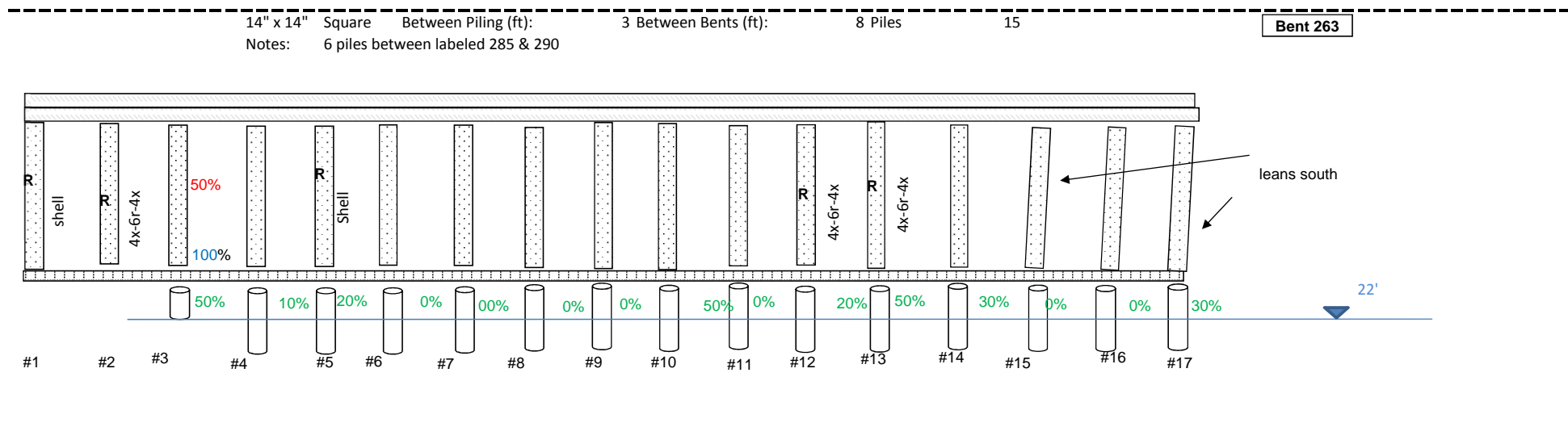
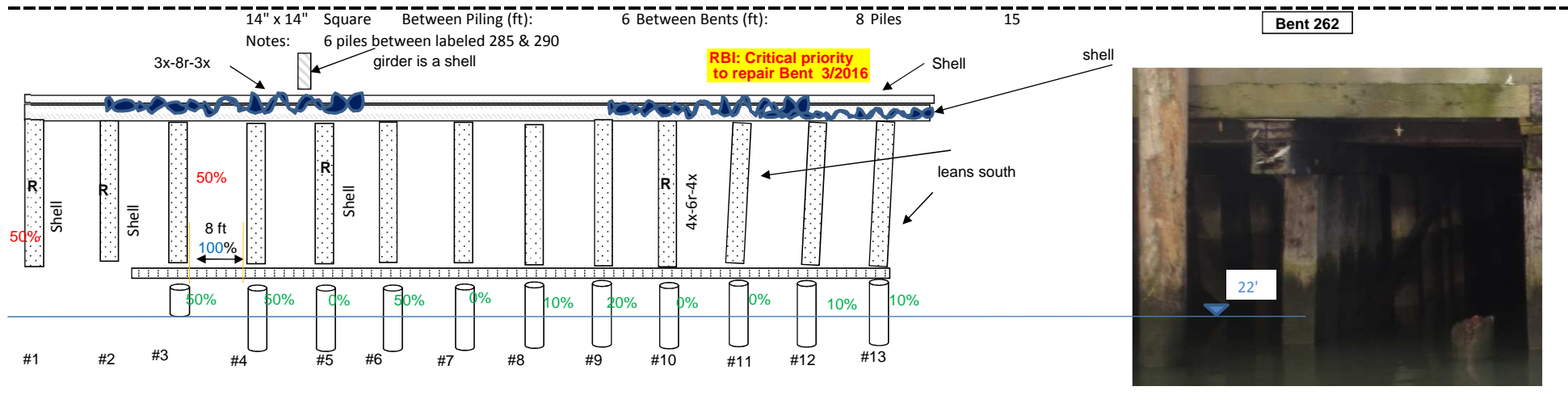

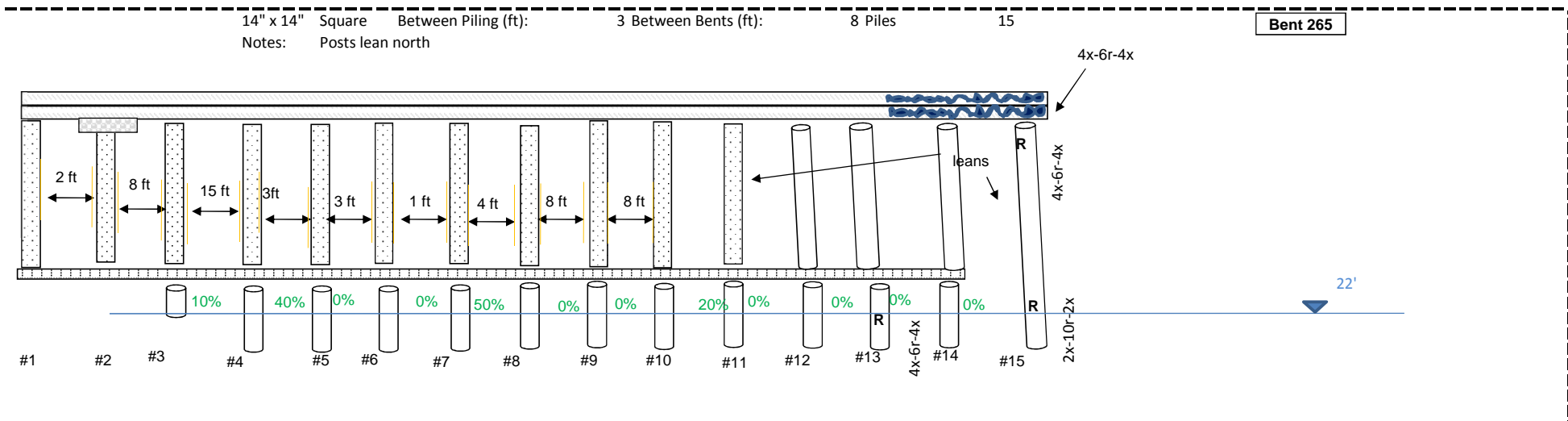
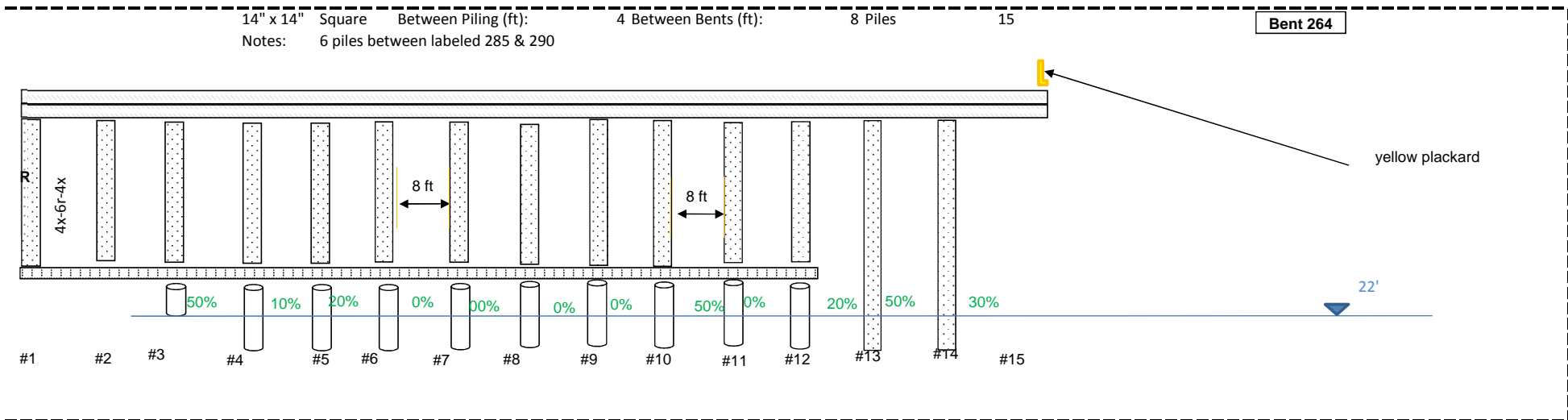

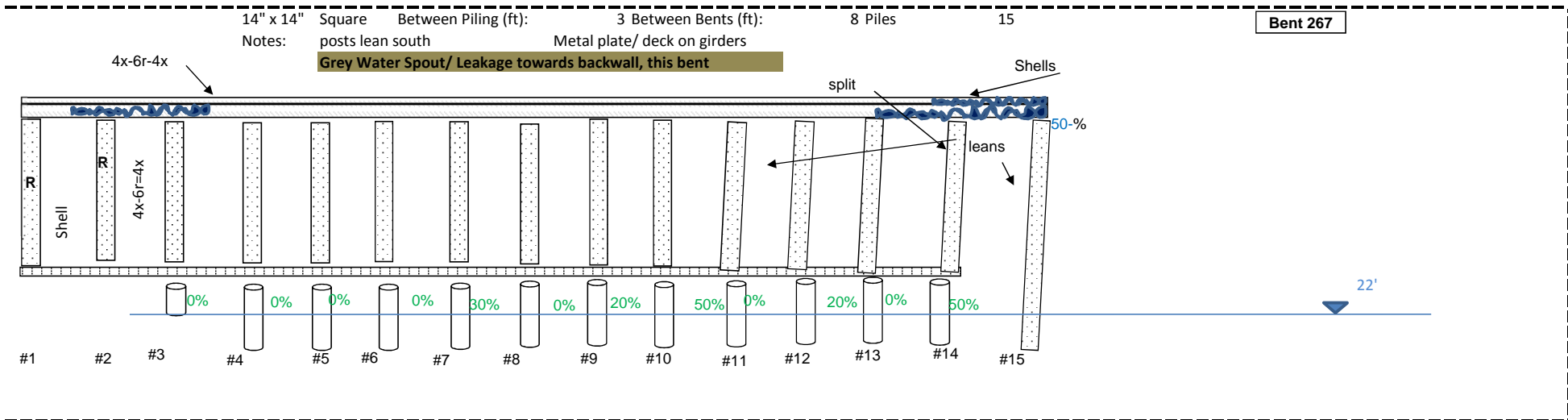
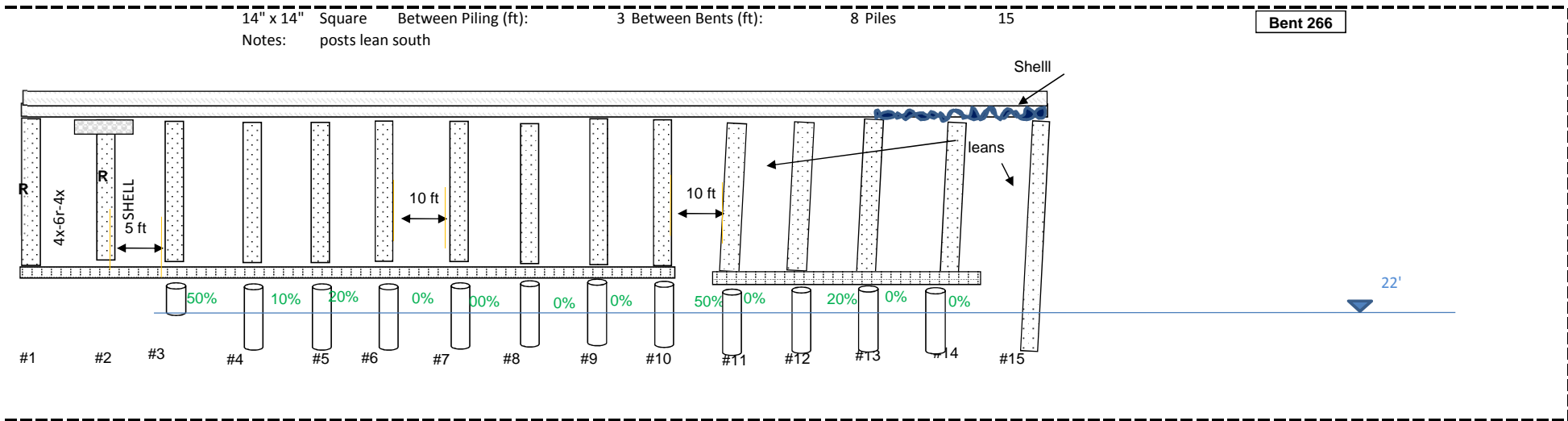

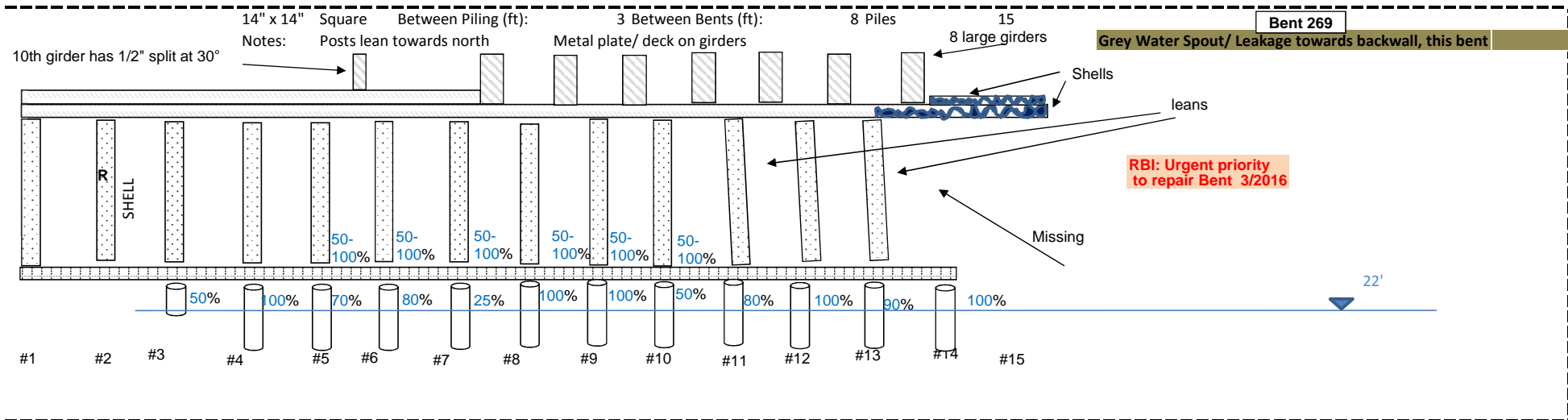
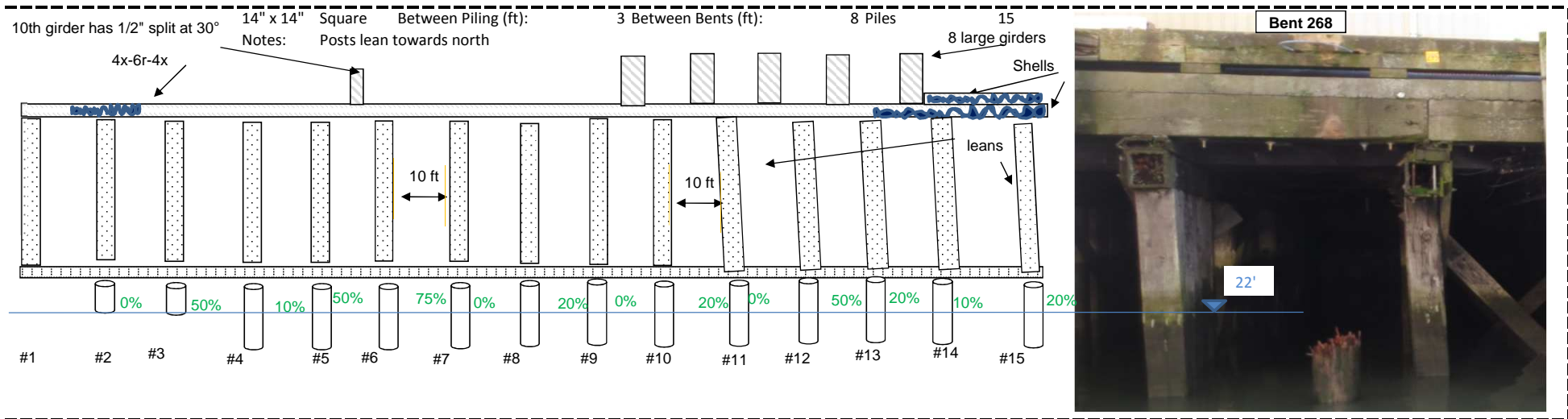

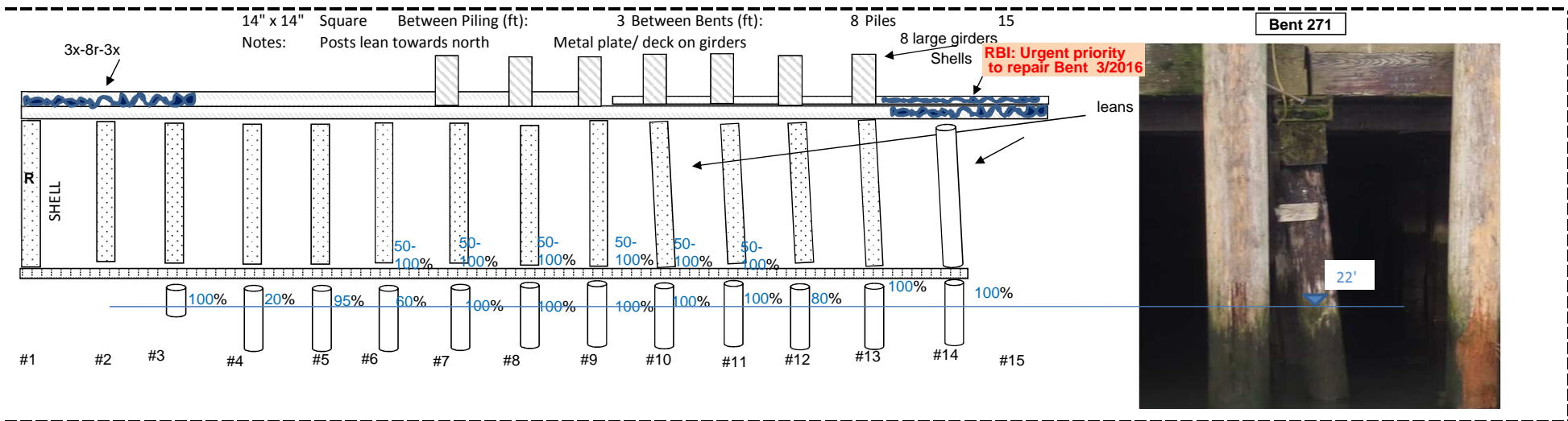
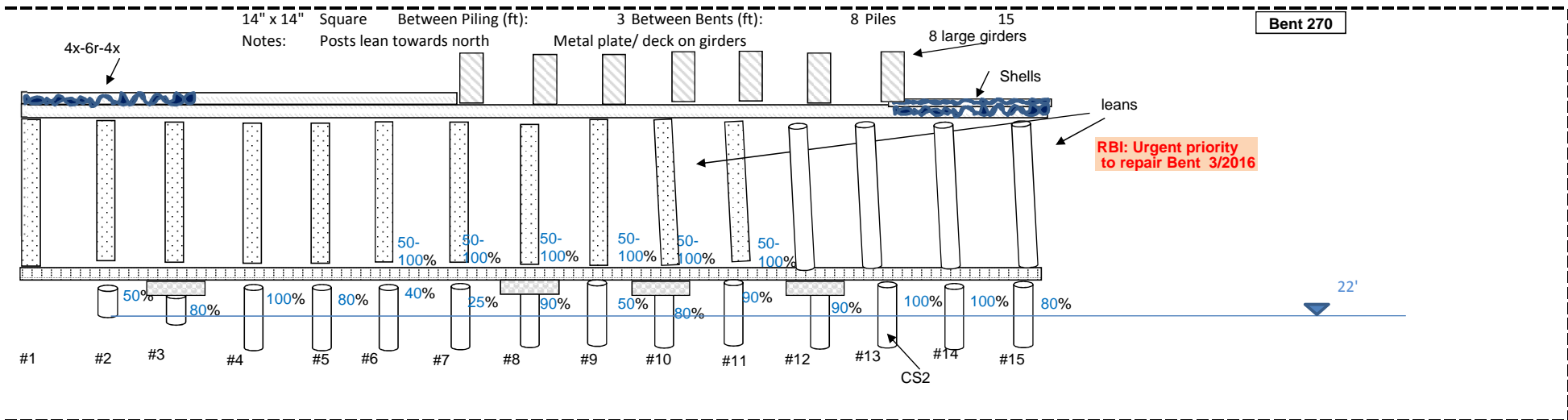

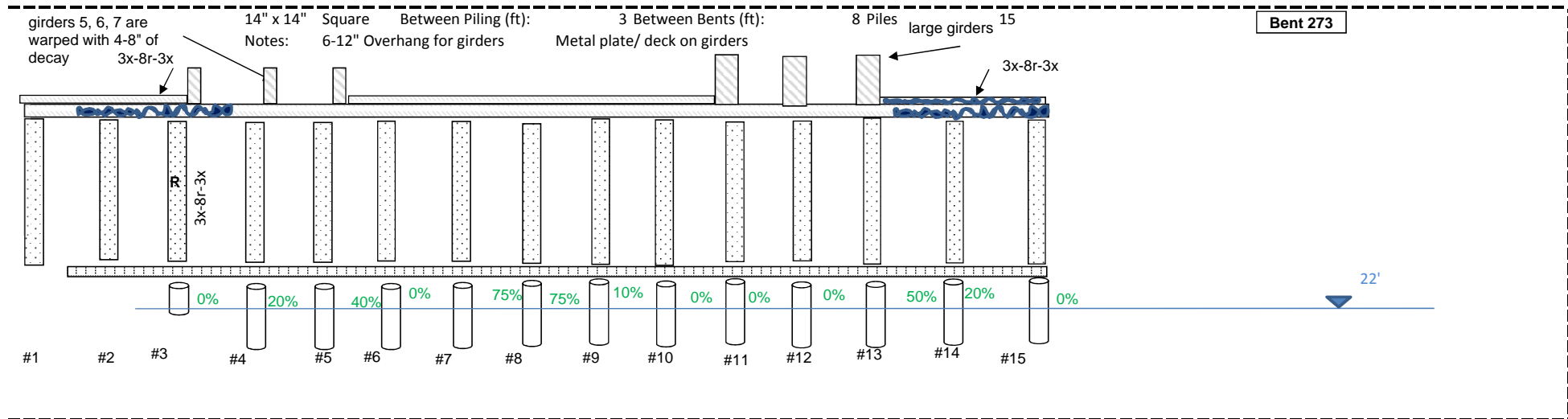
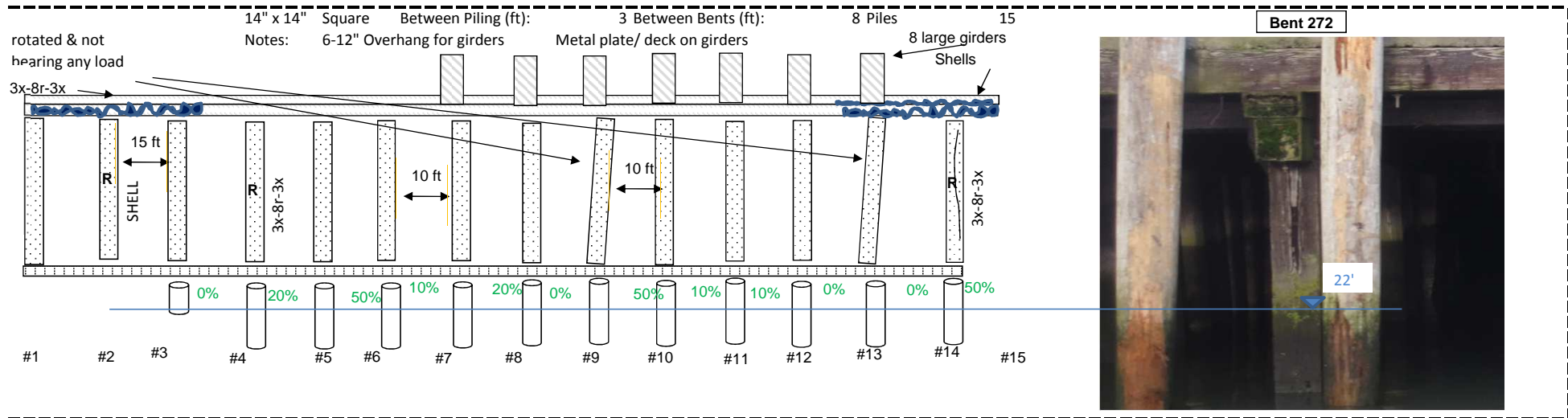



Structure #22526 Unless otherwise noted, piles & columns - CS1, caps & girders - CS2

Note that Bents numbered on the site as 202-229 are just the other end of bents 201 to 189. See figure

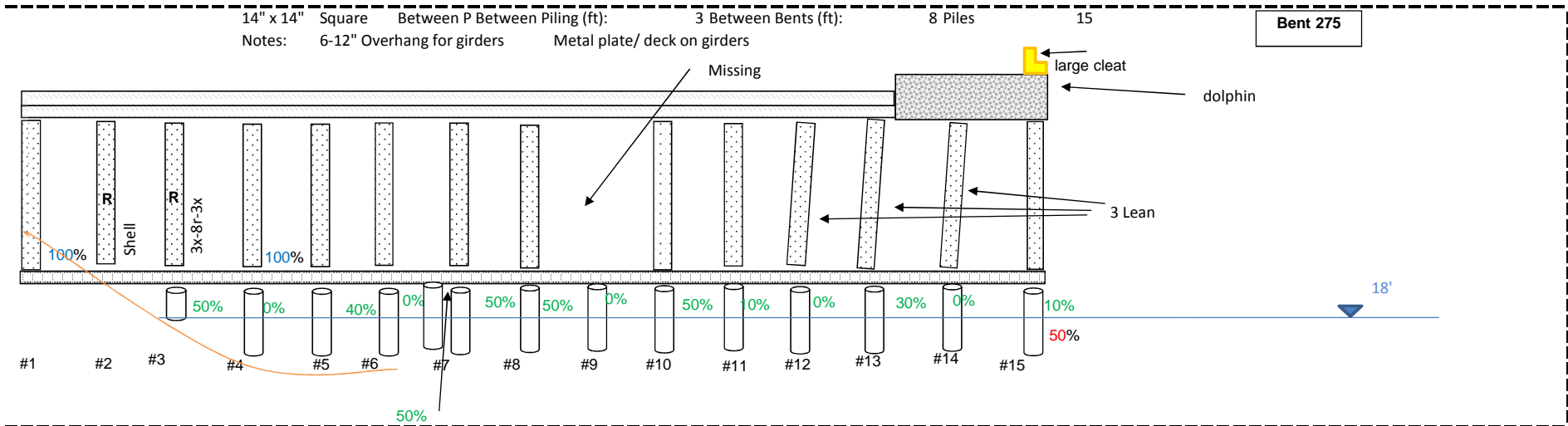
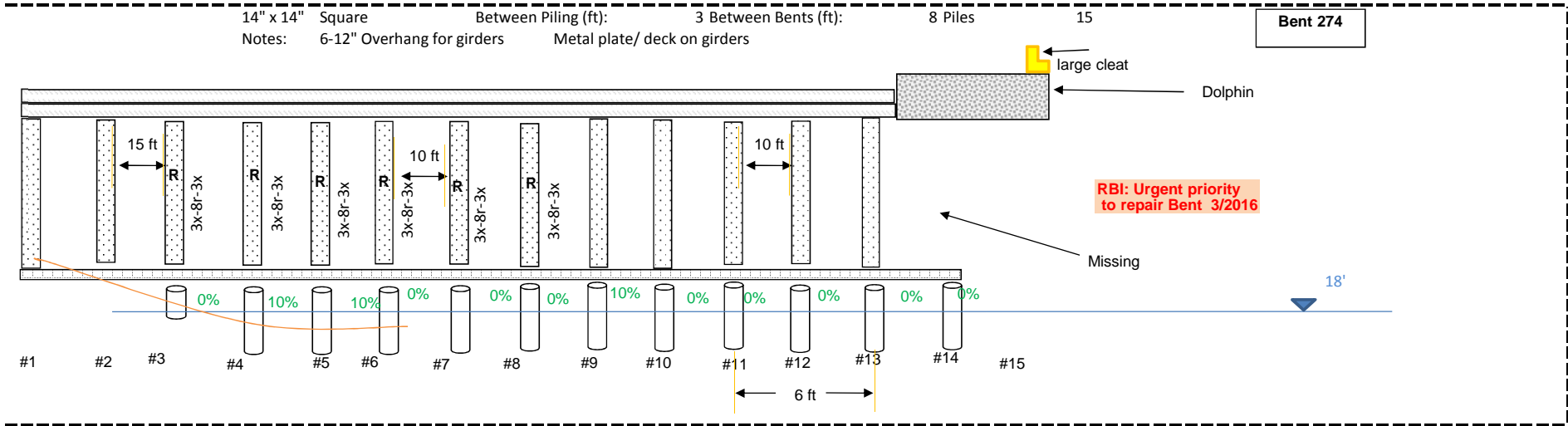

14" x 14" Square Between P Between Piling (ft):
Notes: 6-12" Overhang for girders

3 Between Bents (ft):

12 Piles

15

Bent 276

Girder #12 is broken between bents 276 & 275
from pile 12 out, the section has failed

cap is ~8" x 10"

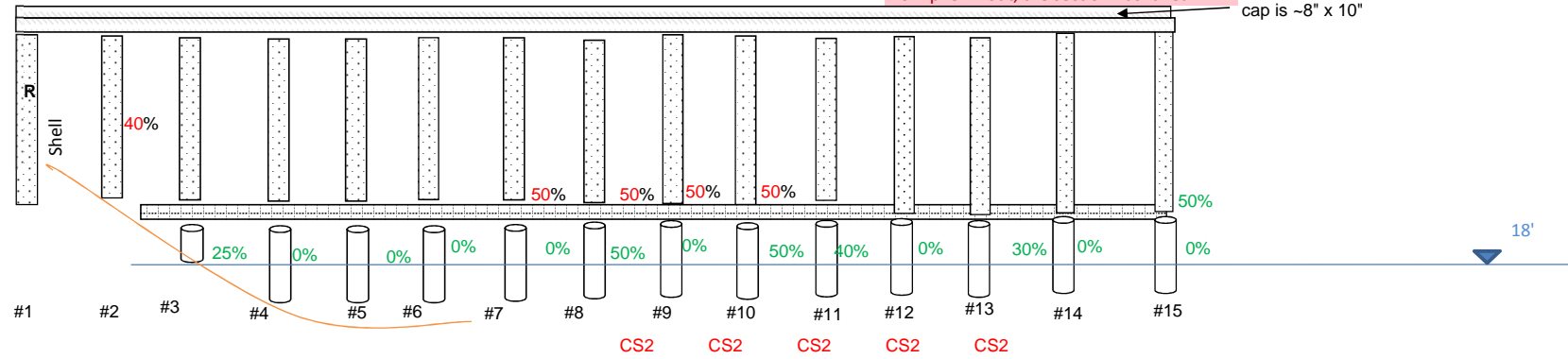

14" x 14" Square Between P Between Piling (ft):
Notes: 6-12" Overhang for girders

3 Between Bents (ft):

12 Piles

15

Bent 277

Bt. 303 from outside, might be marked 305 toward land

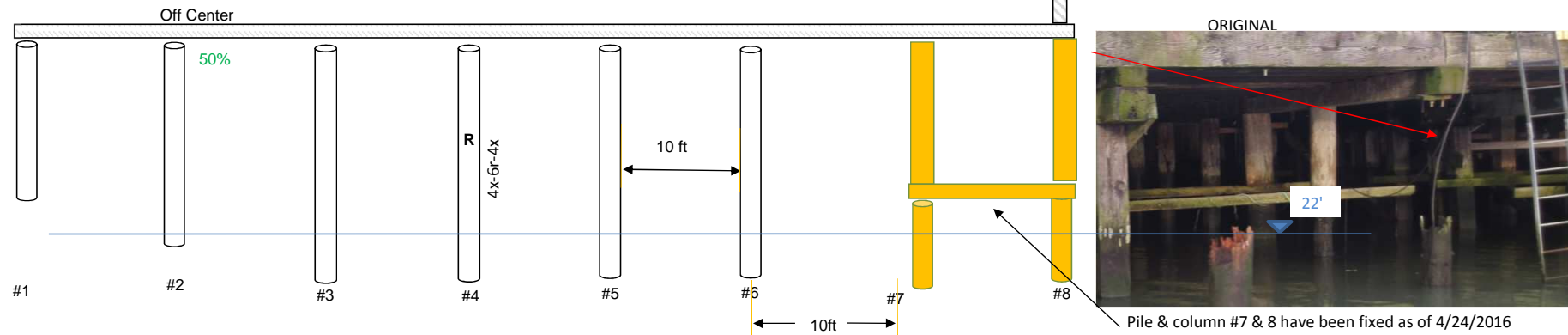

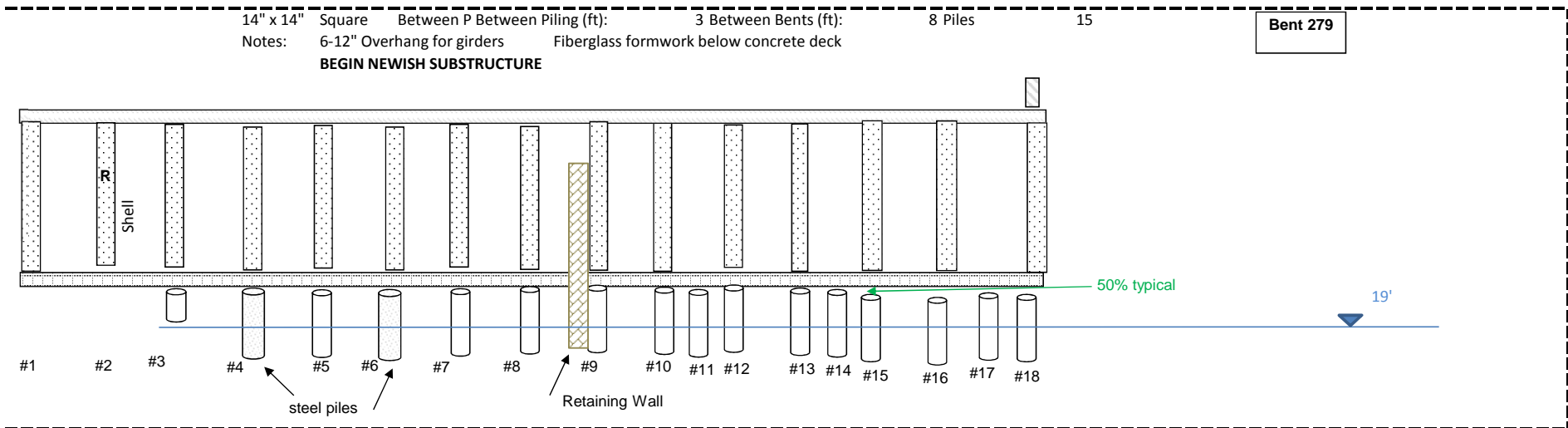
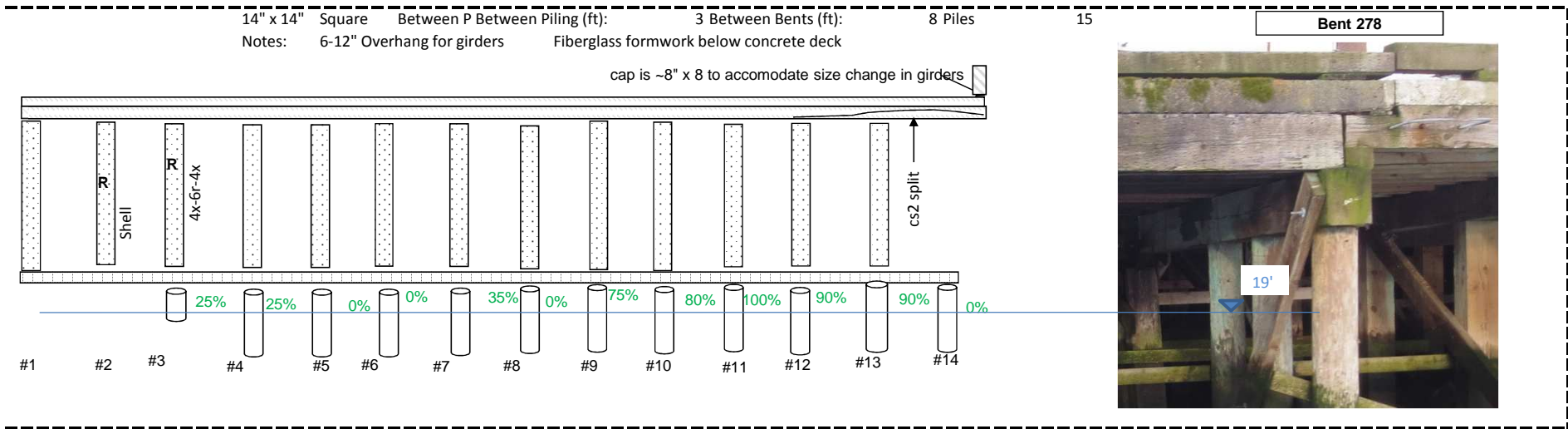

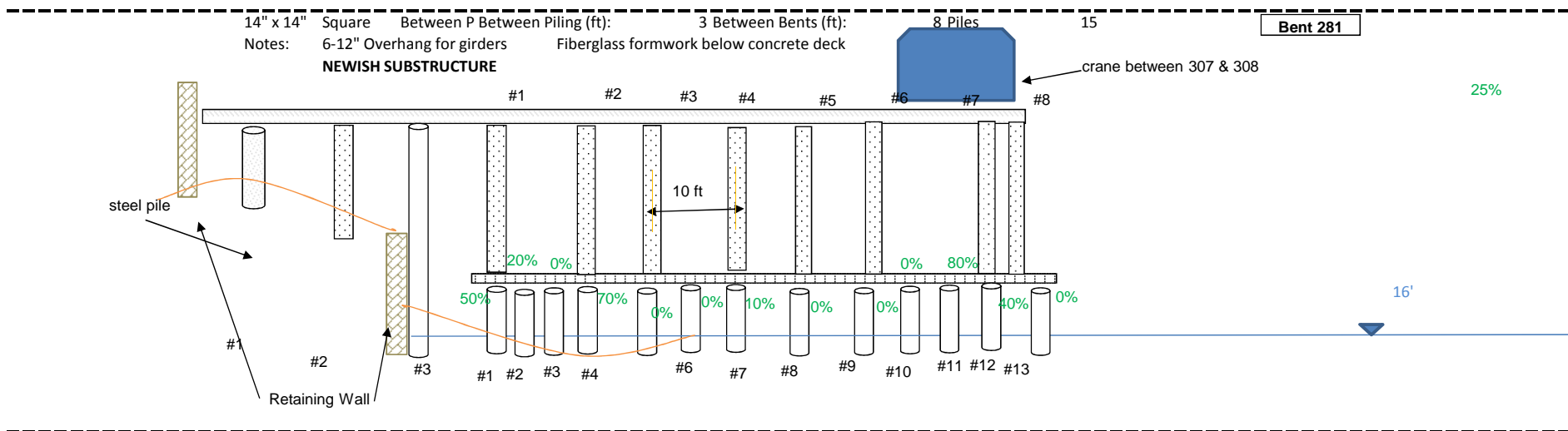
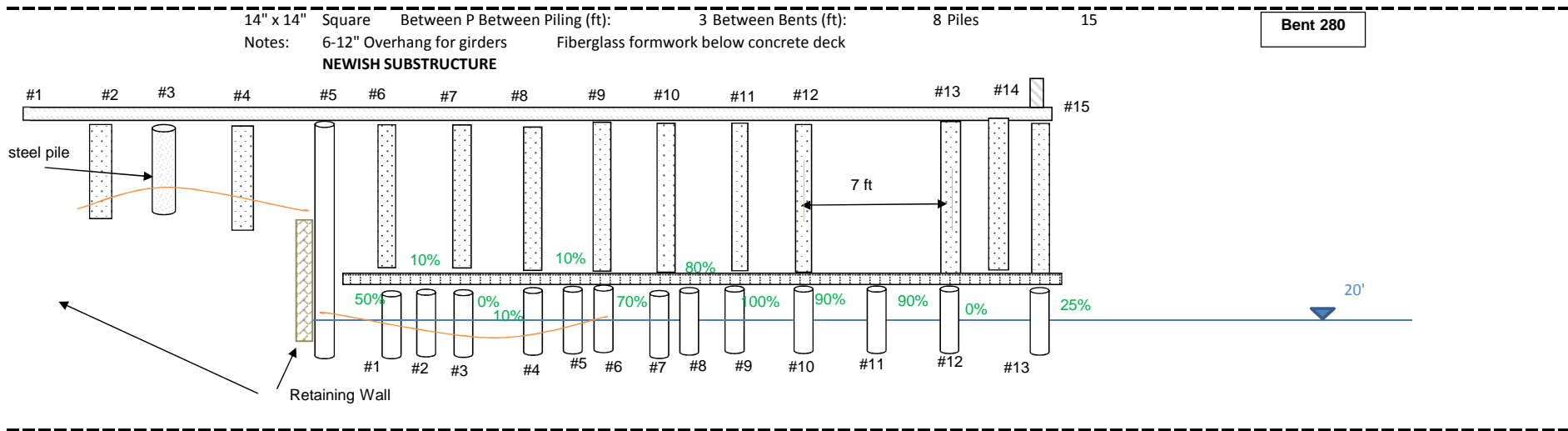

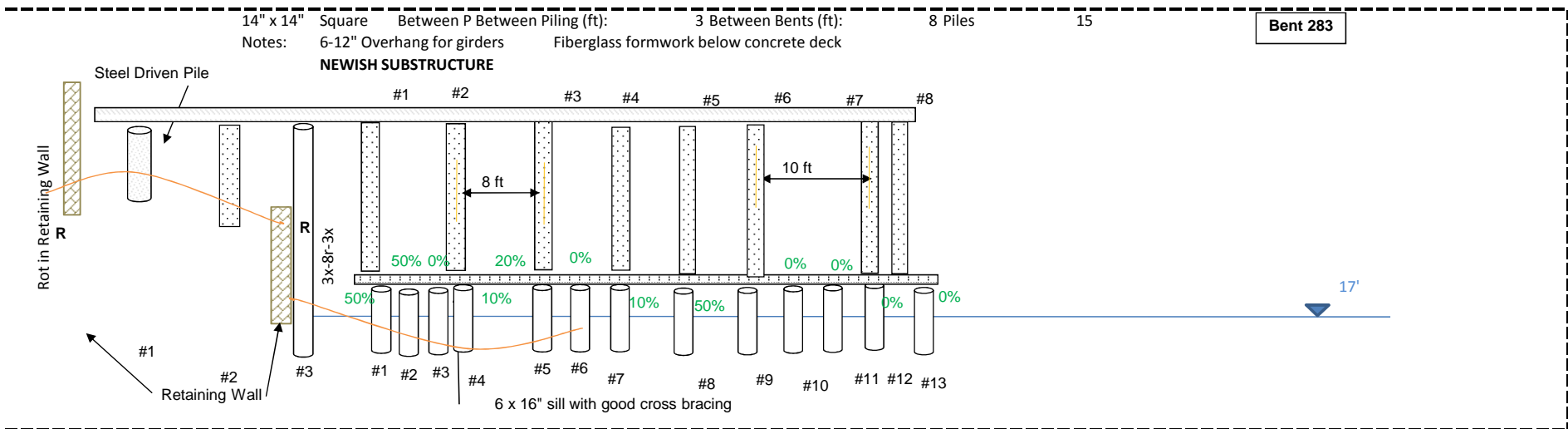
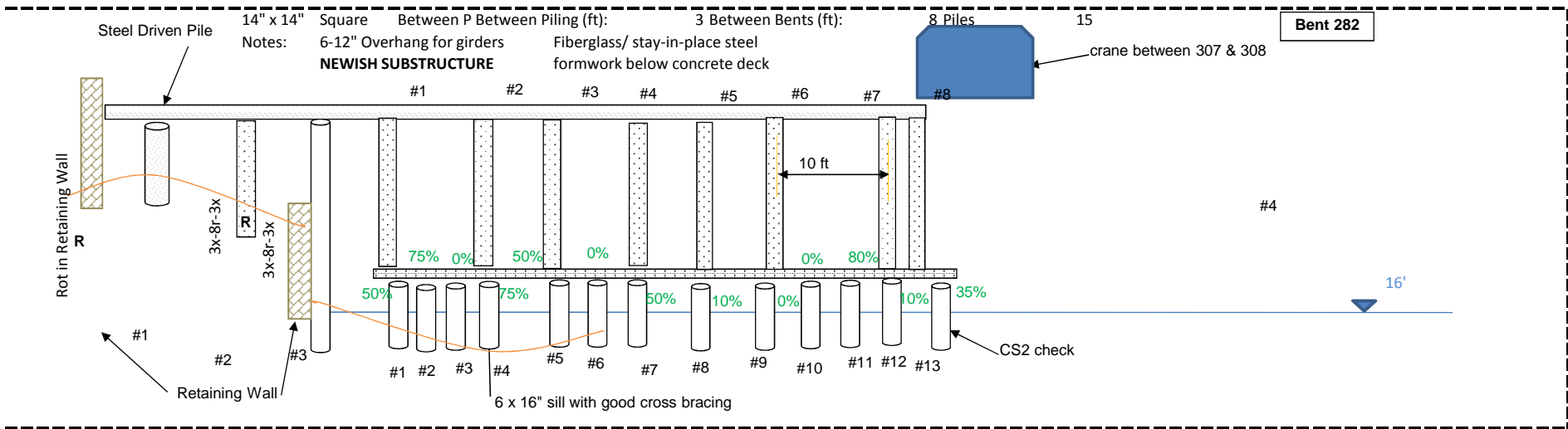

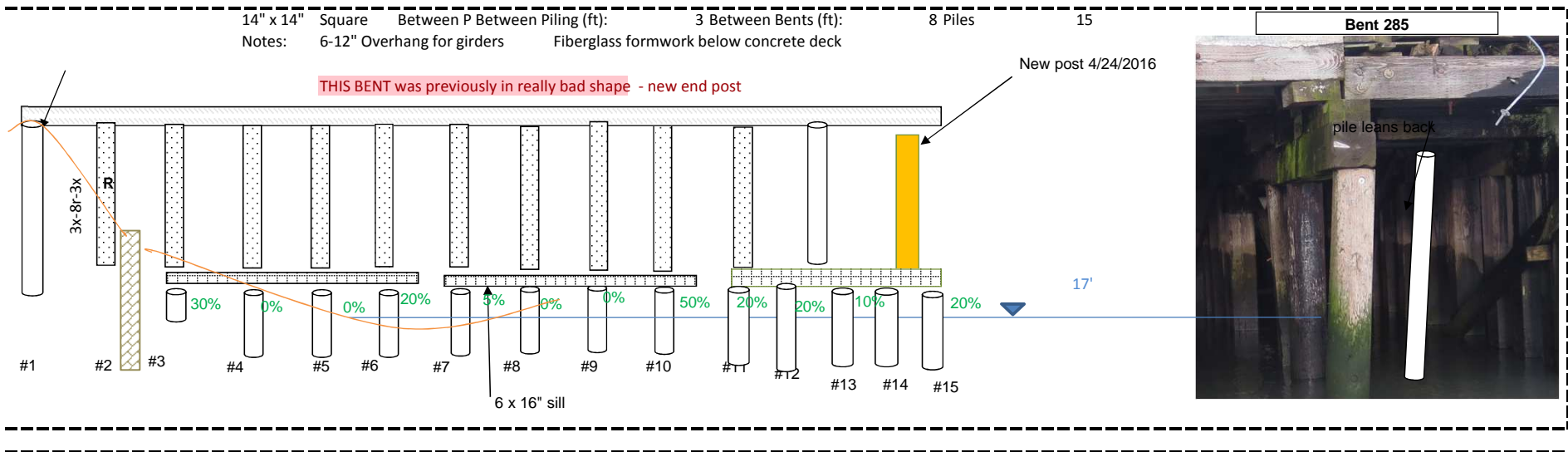
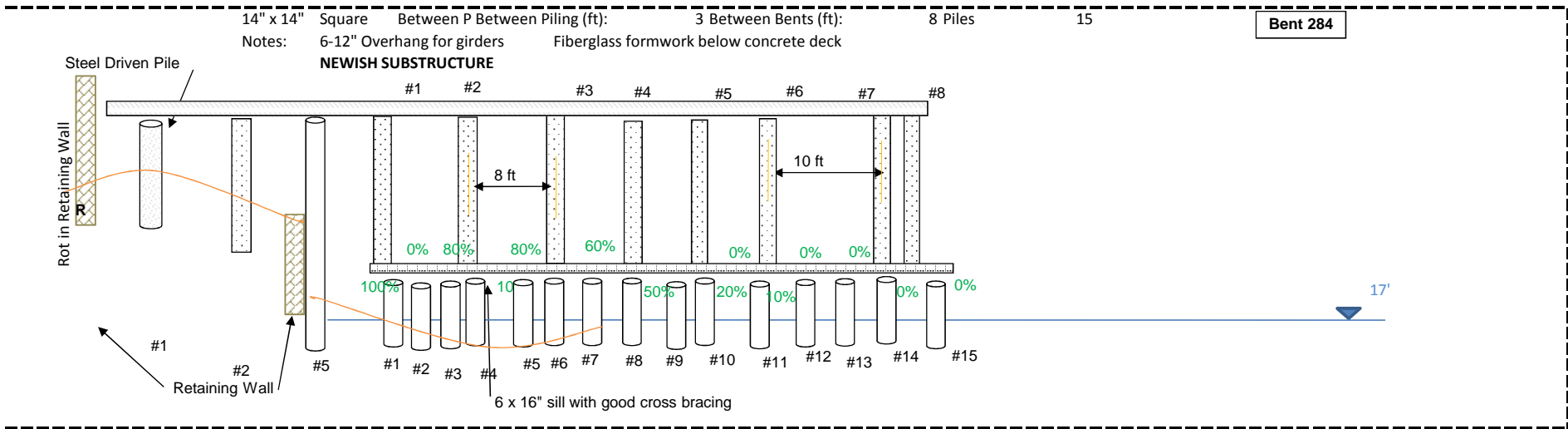

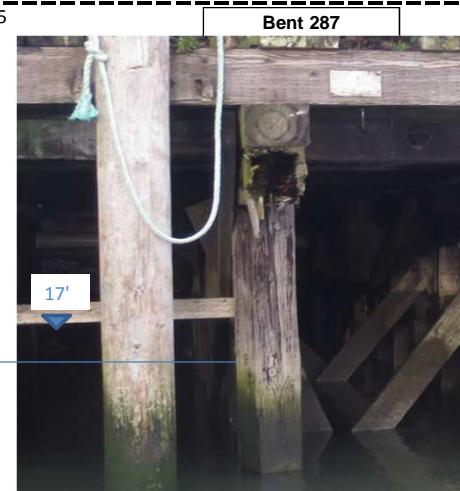
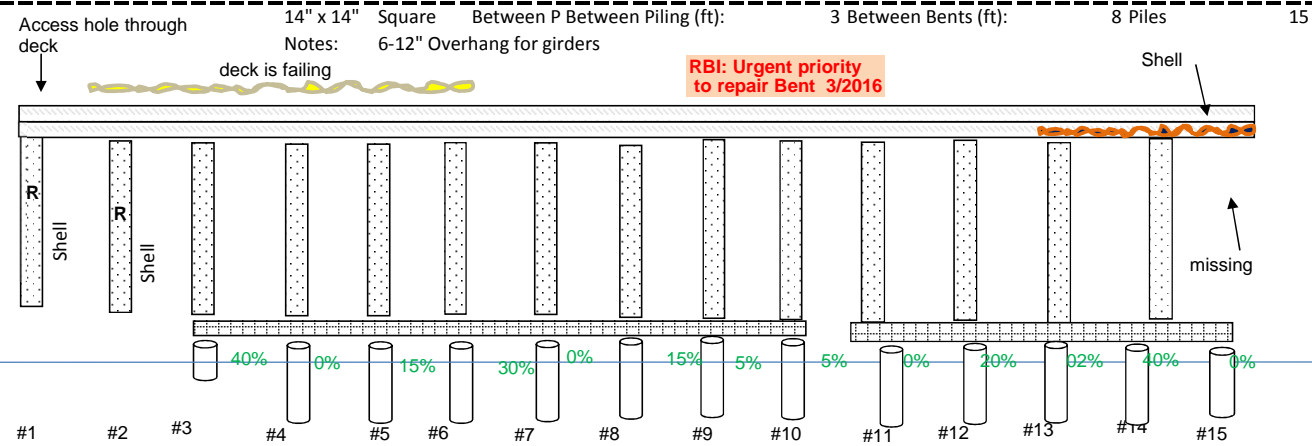
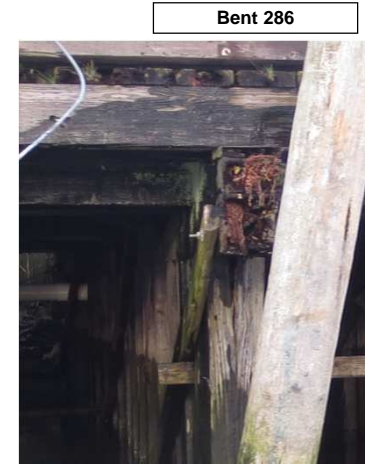
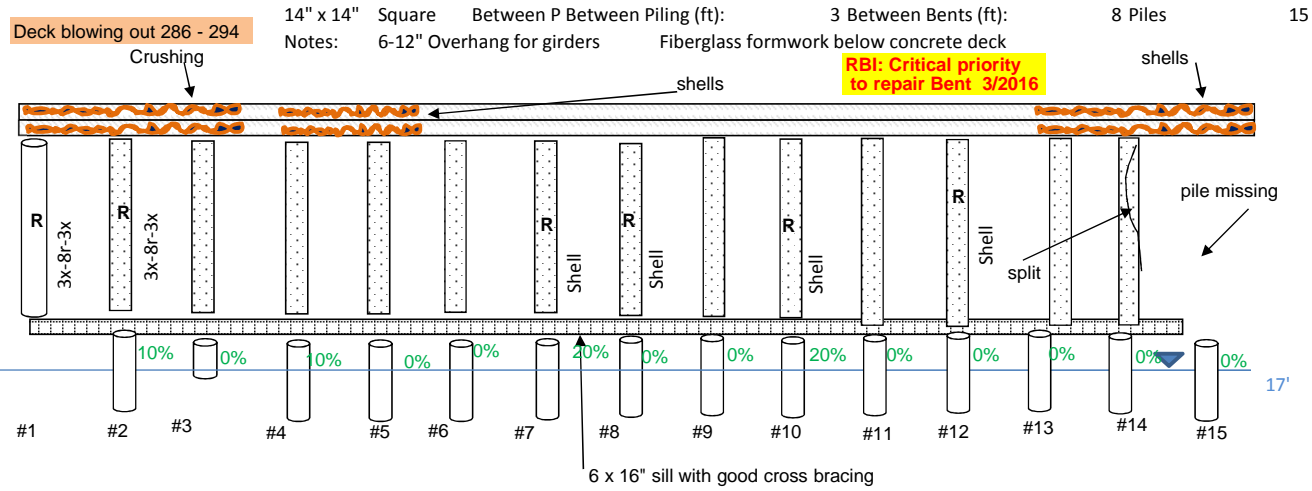

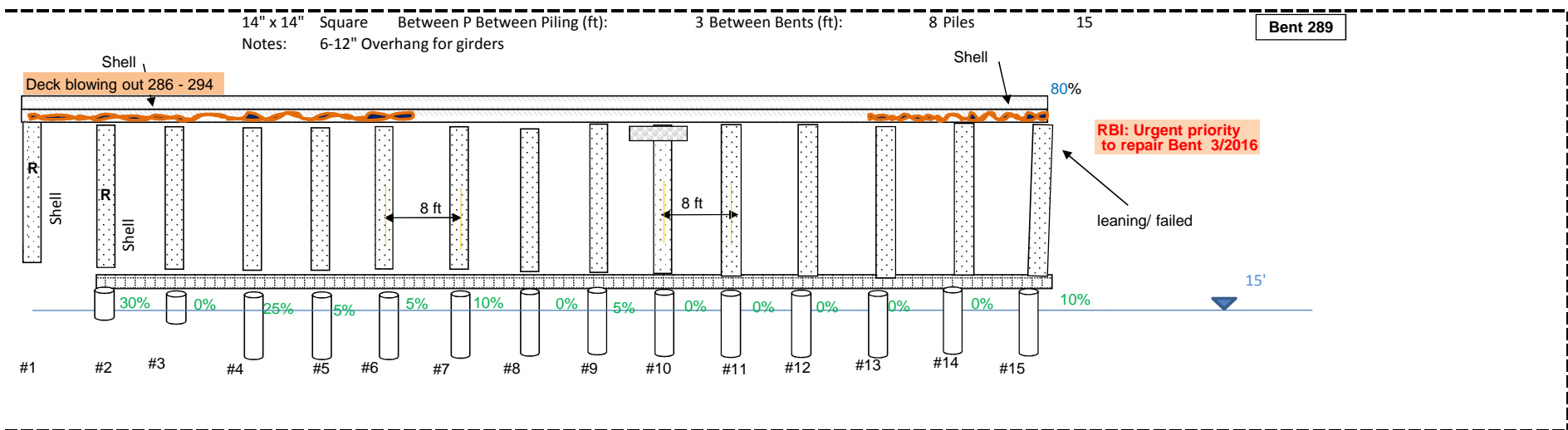
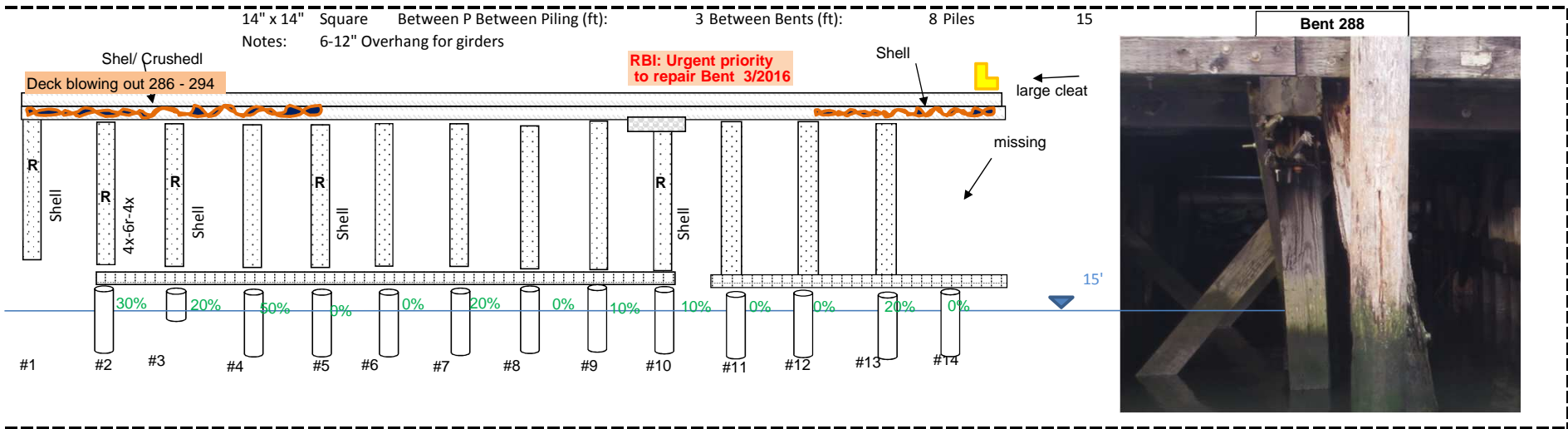

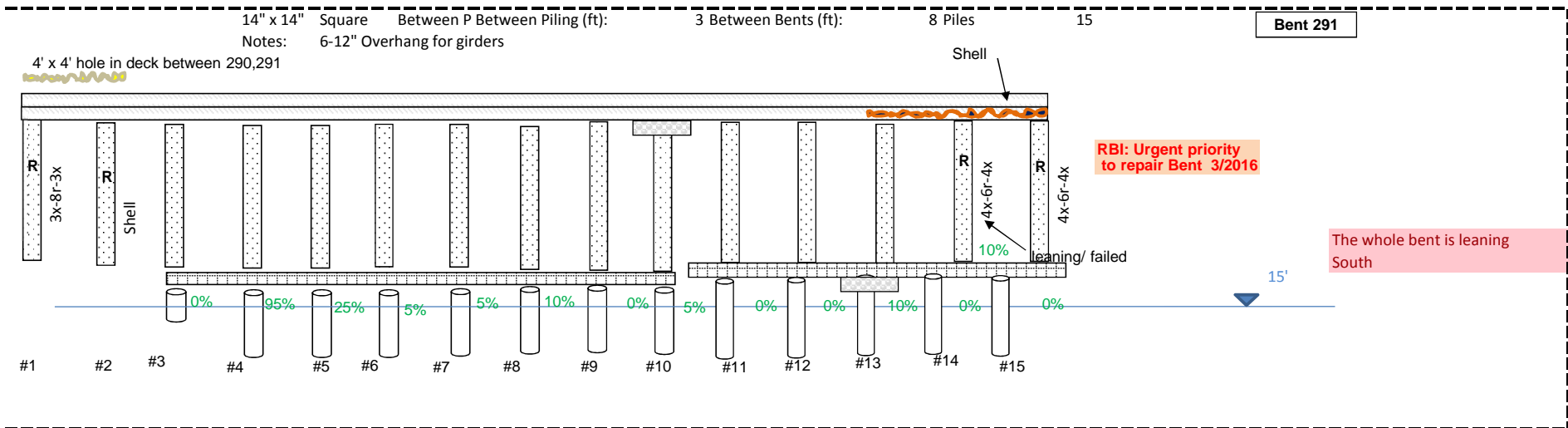
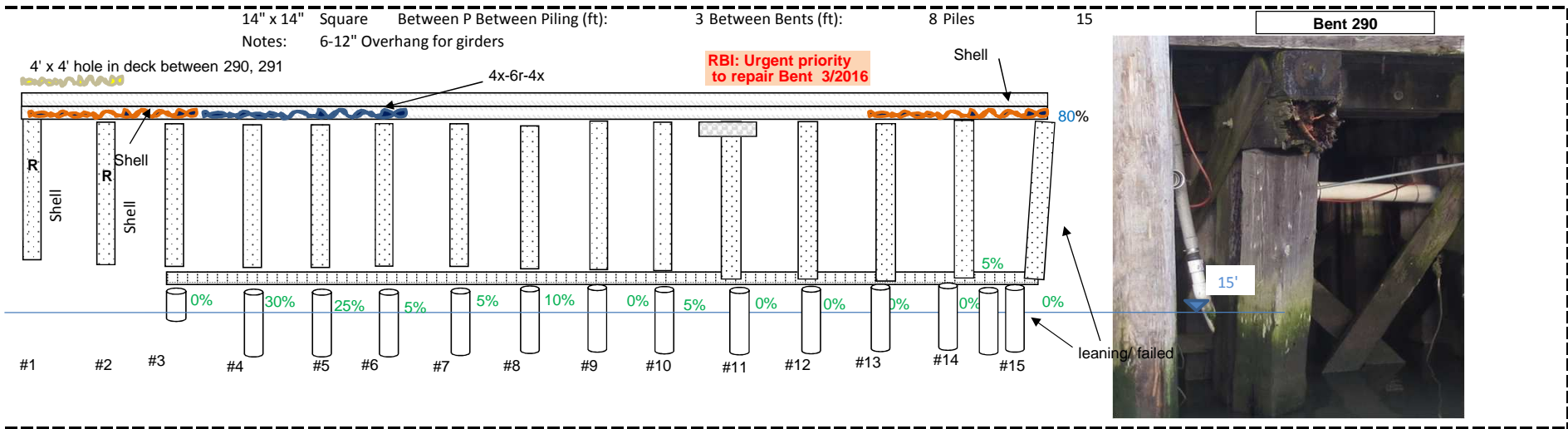

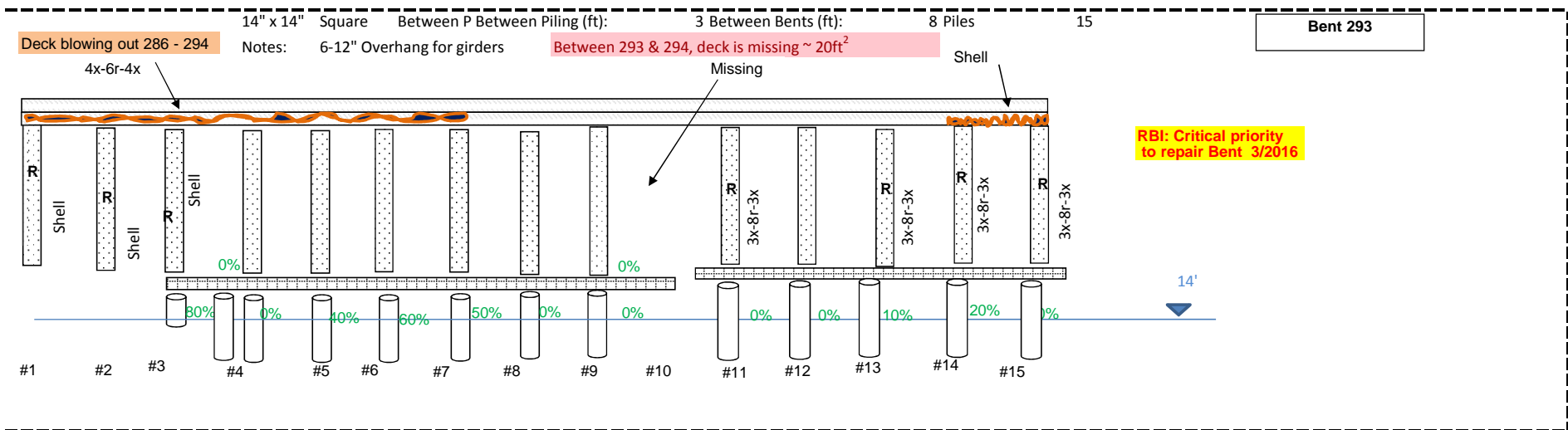
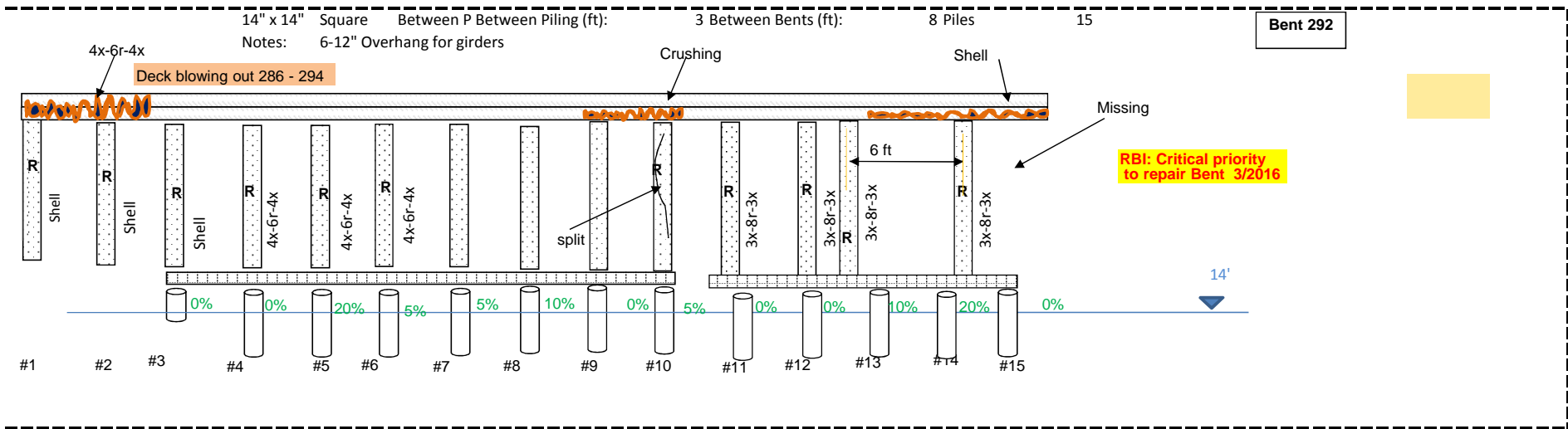

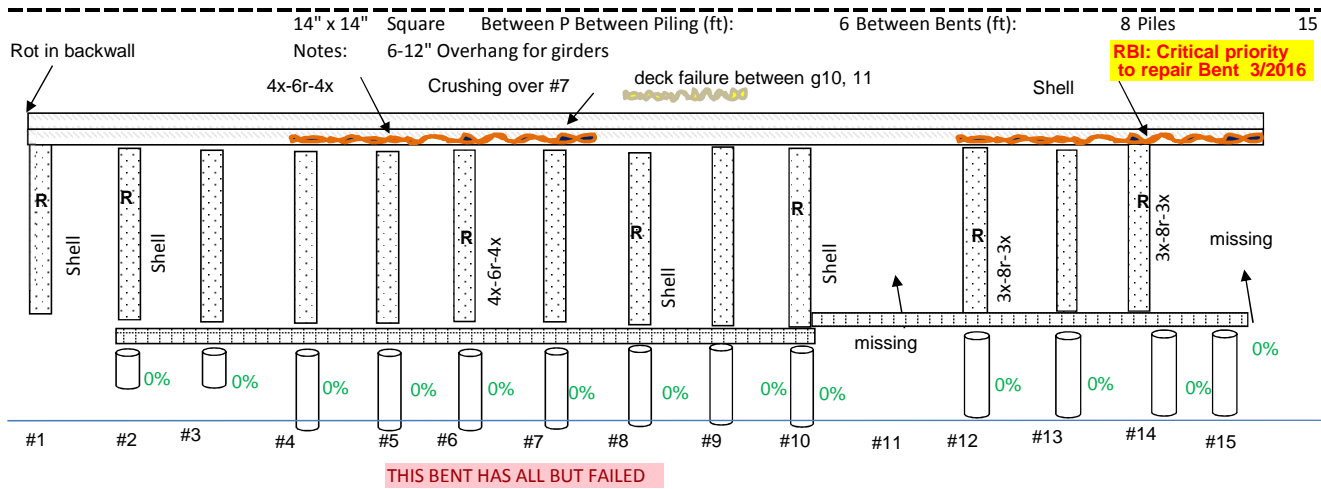
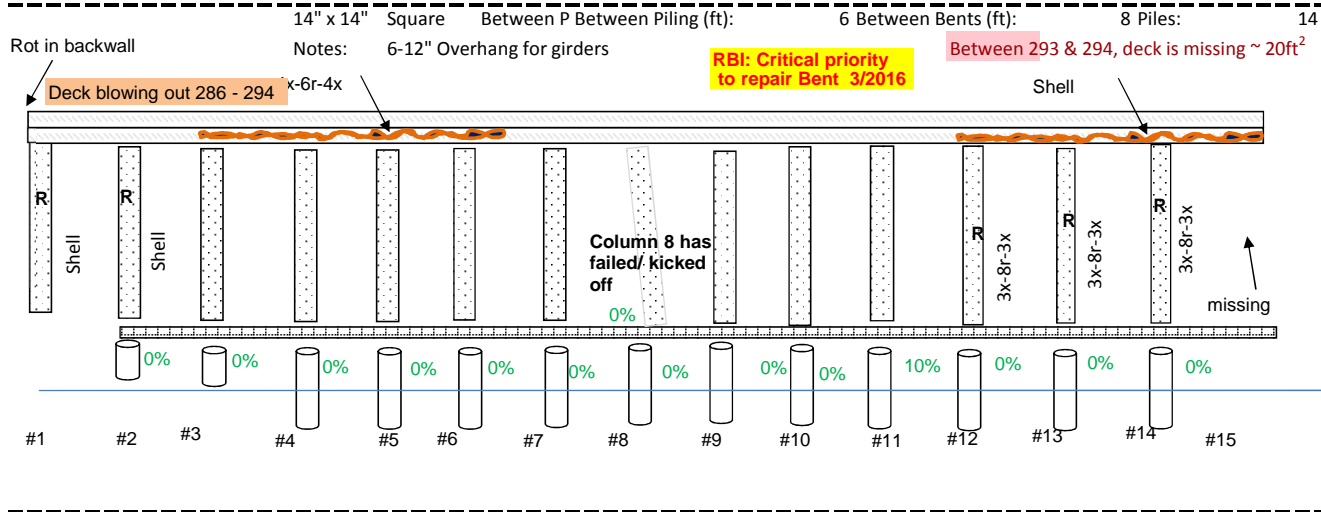

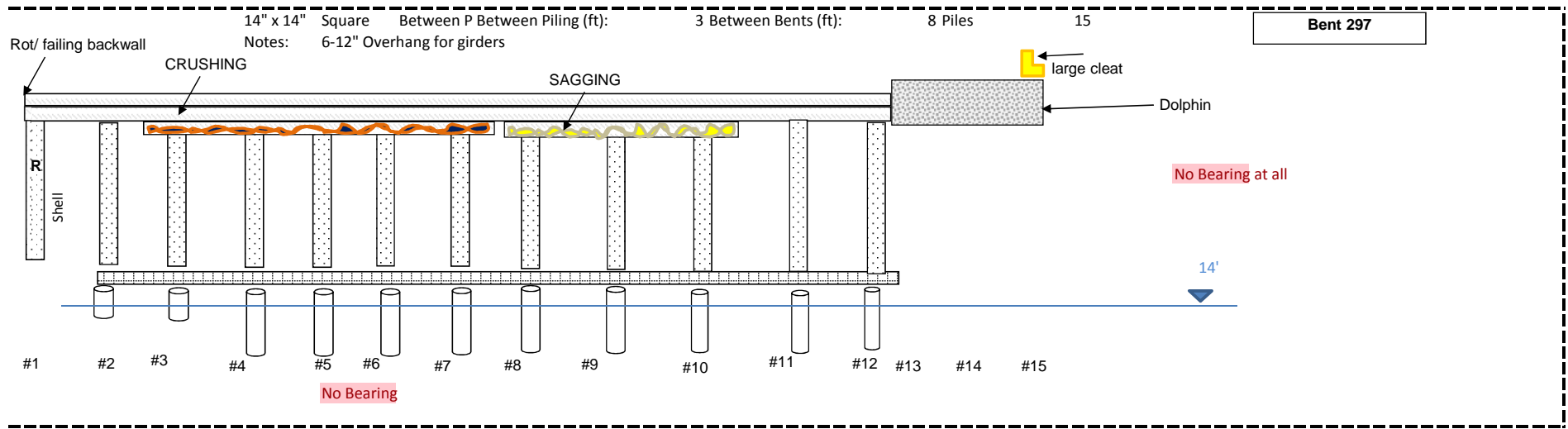
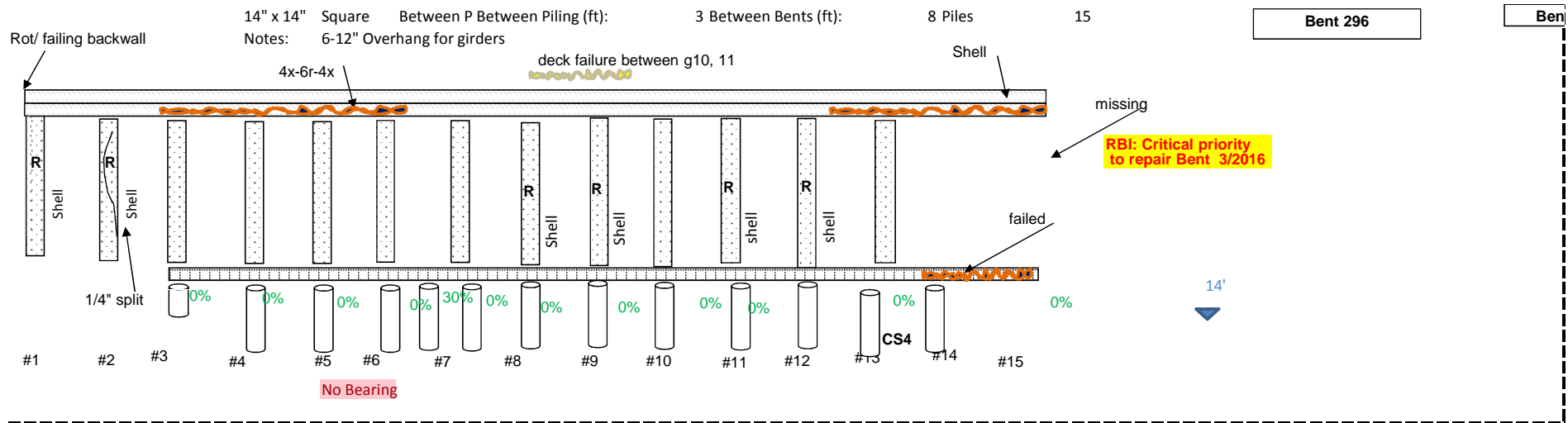

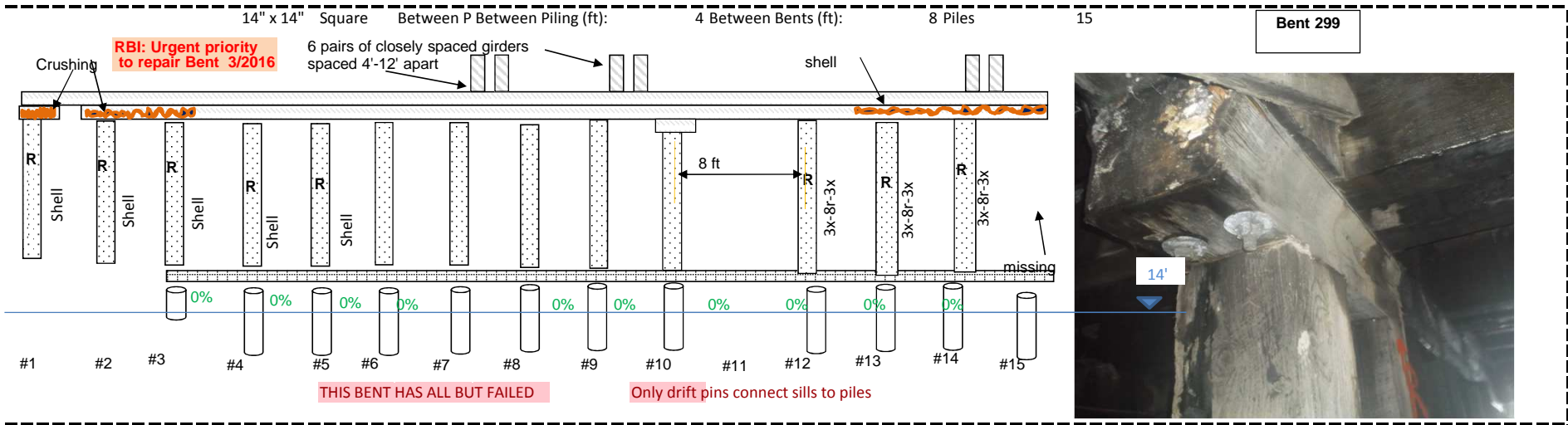
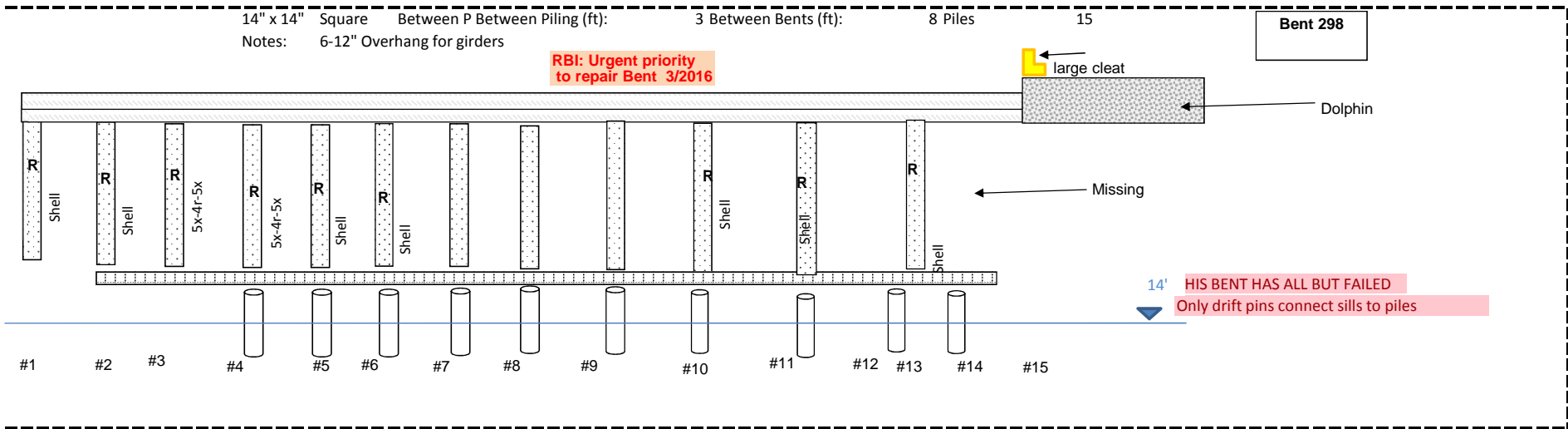

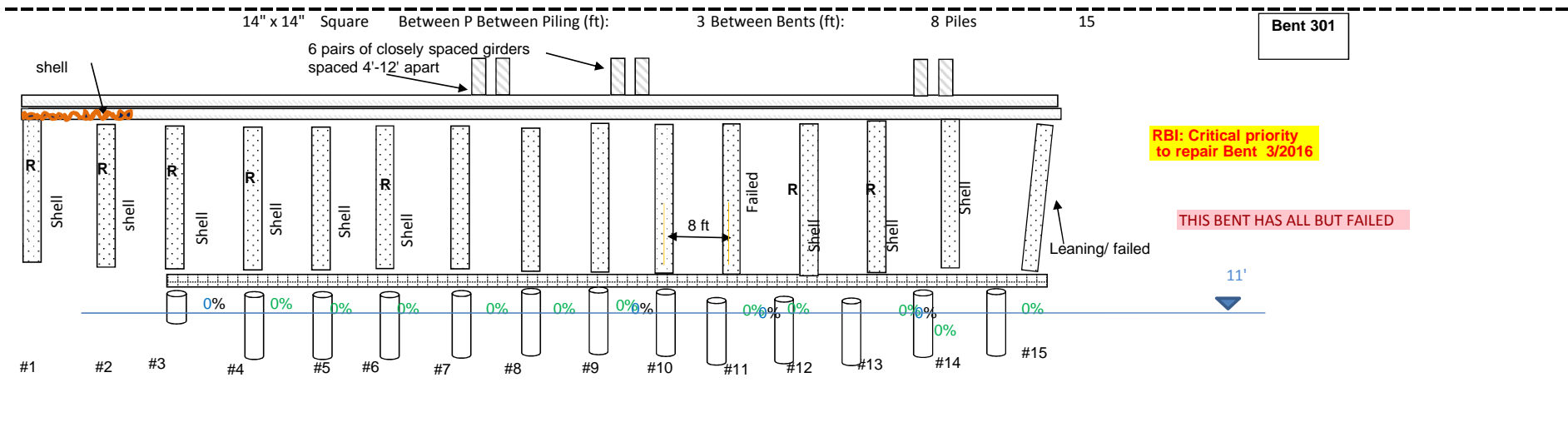
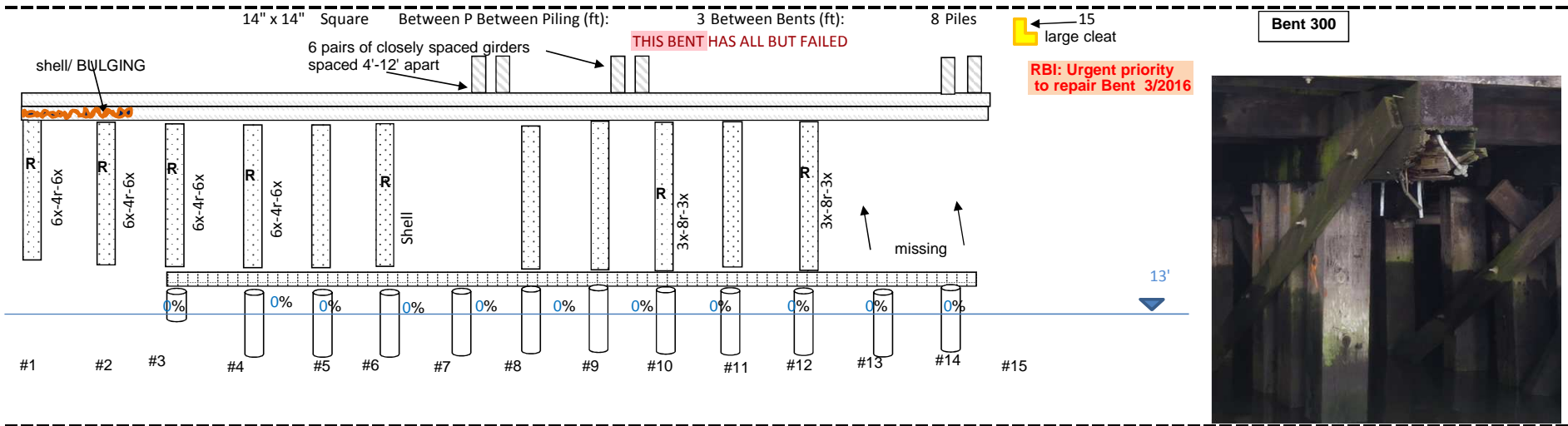

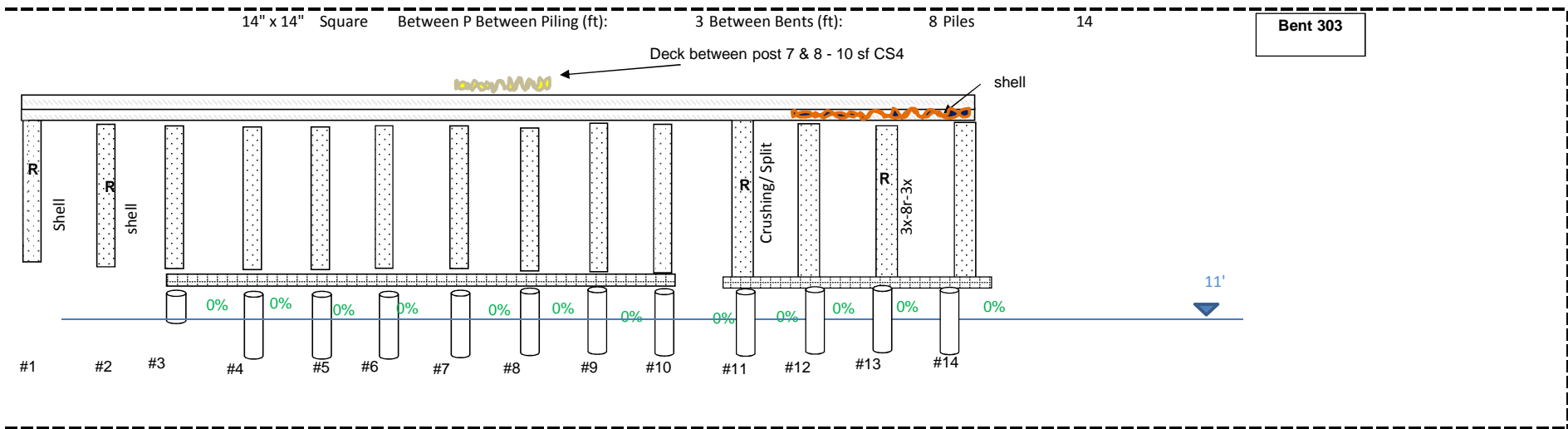
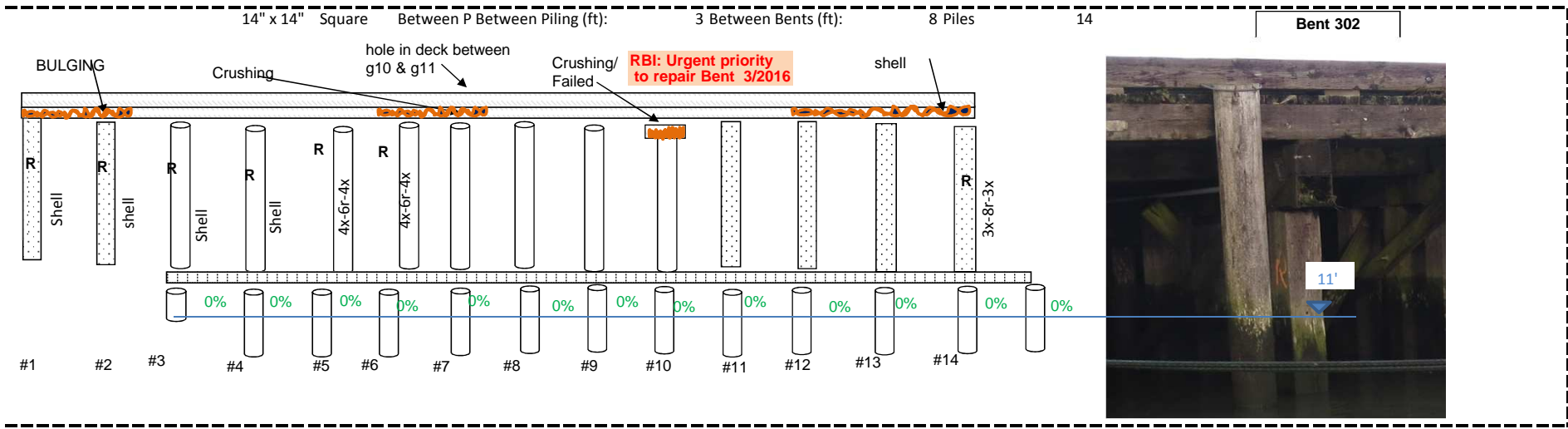

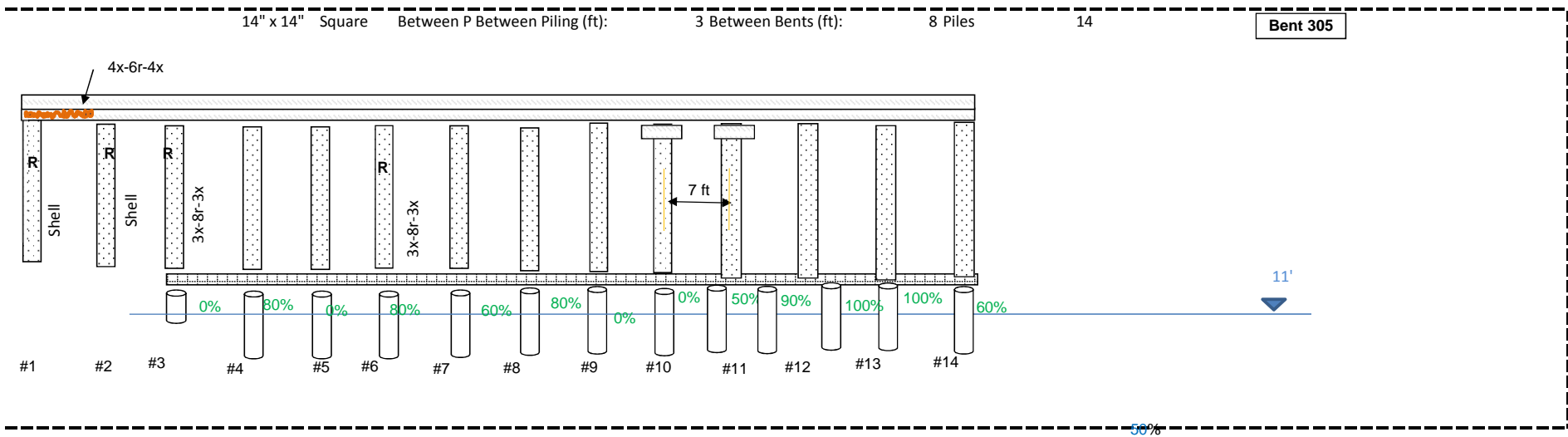
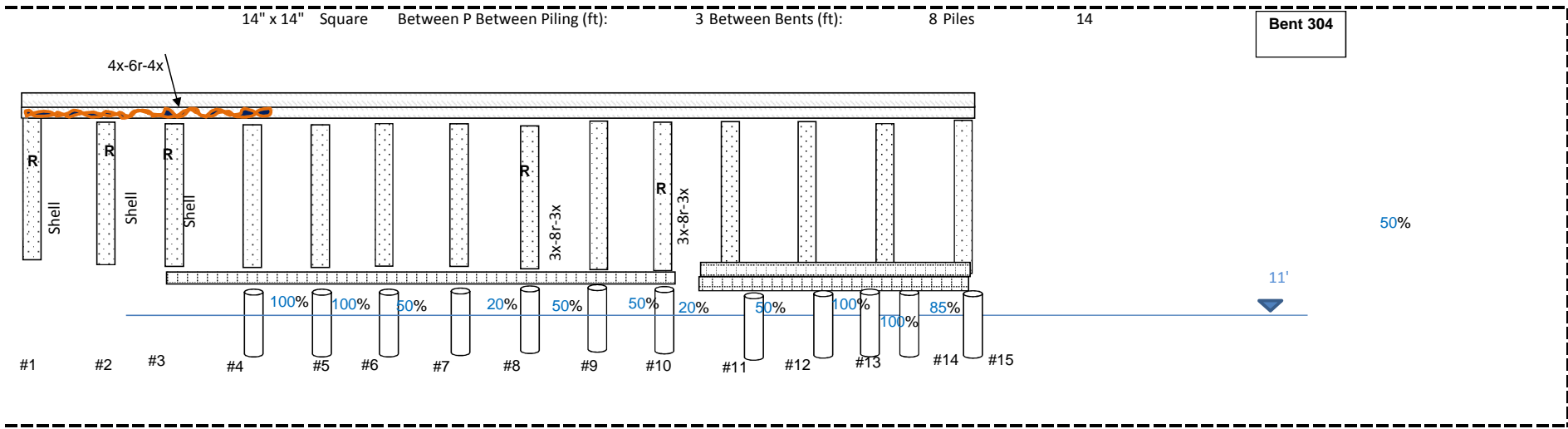

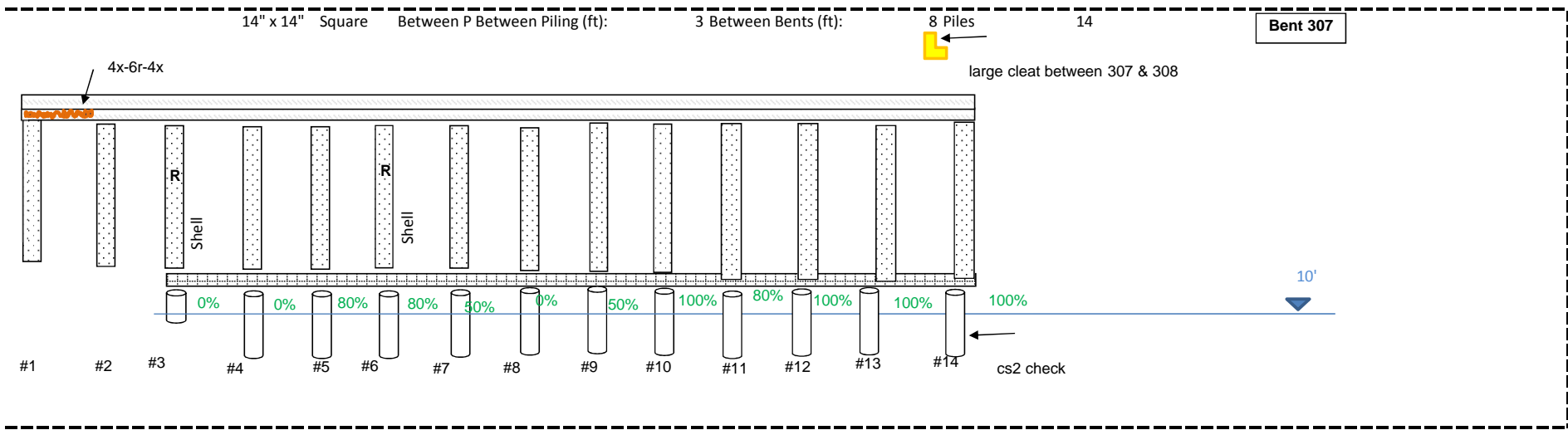
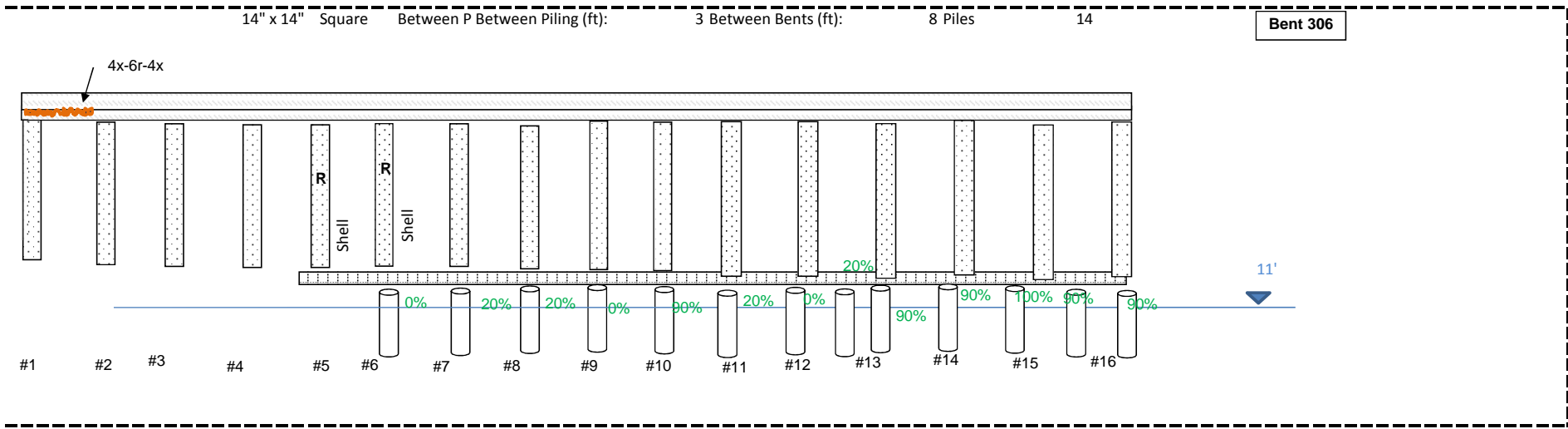

14" x 14" Square

Between P Between Piling (ft):

3 Between Bents (ft):

8 Piles

14

Bent 308

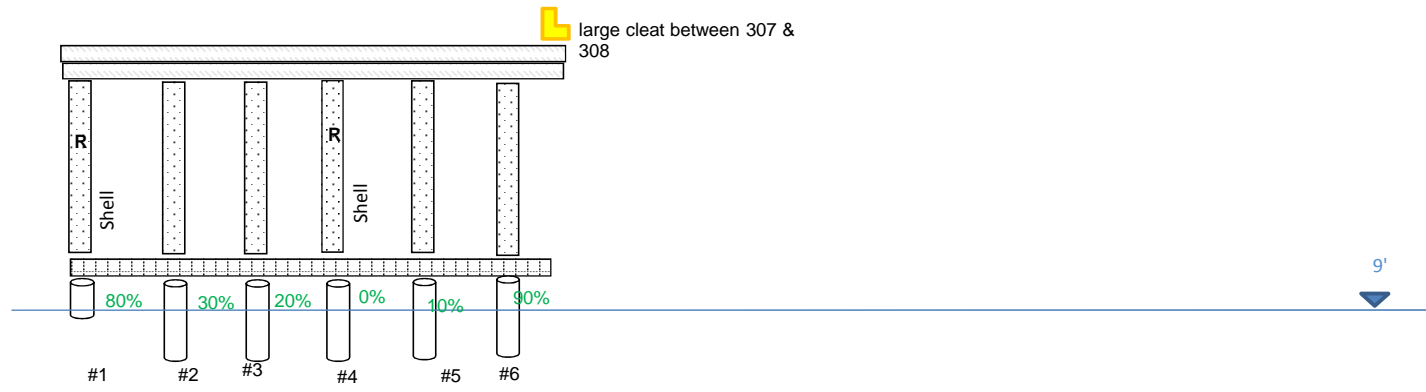

Port of Astoria Pier 2
 Results of Inspection 9/2015 & 1/2016

Cross Bracing & Girders generally not pictured
 3-4 girders per pile. Girders are 13.5" x 6"
 Caps are 14" x 14"

Blue Bearing Loss
 Red Section Loss

22527	Green is Percent Bearing Remaining	14" Dia	Between Piling	6	Between Bents	10	6 #22527	1/3	Bent F
Notes: 6" overhang of girders Access F-A from opening in Deck (may need help getting back up though)									

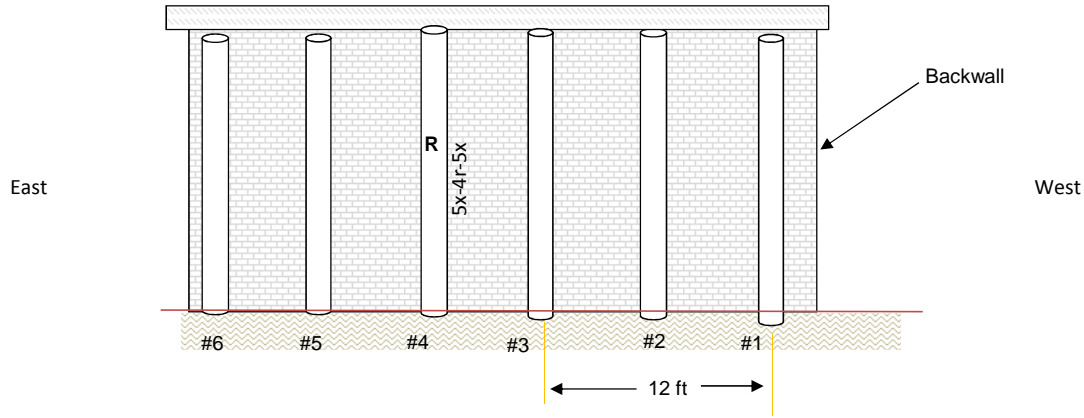

14" Dia	Between Piling	6	Between Bents	10	Bent E
Notes: 6" overhang of girders					

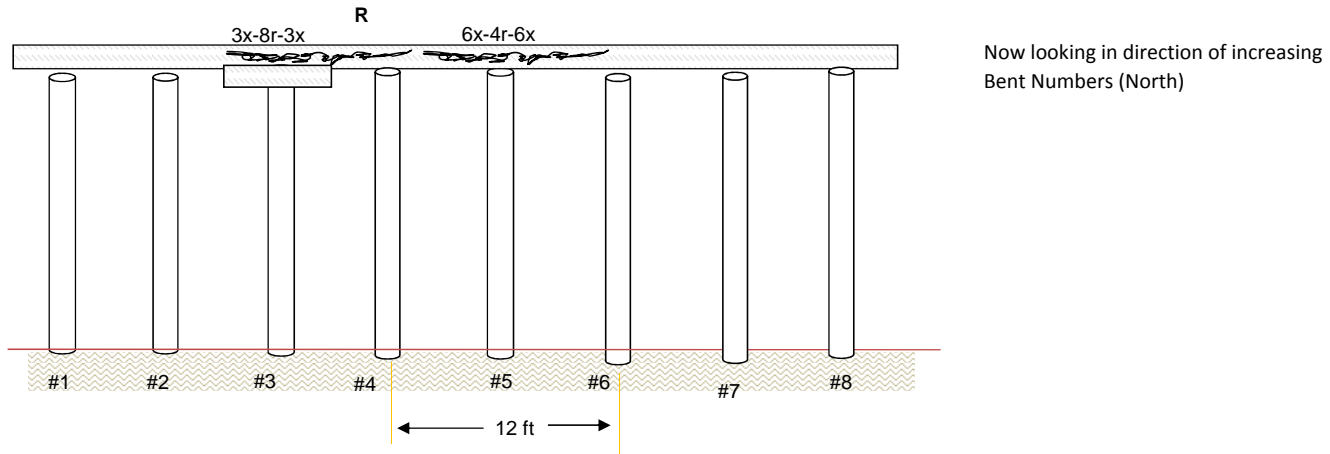

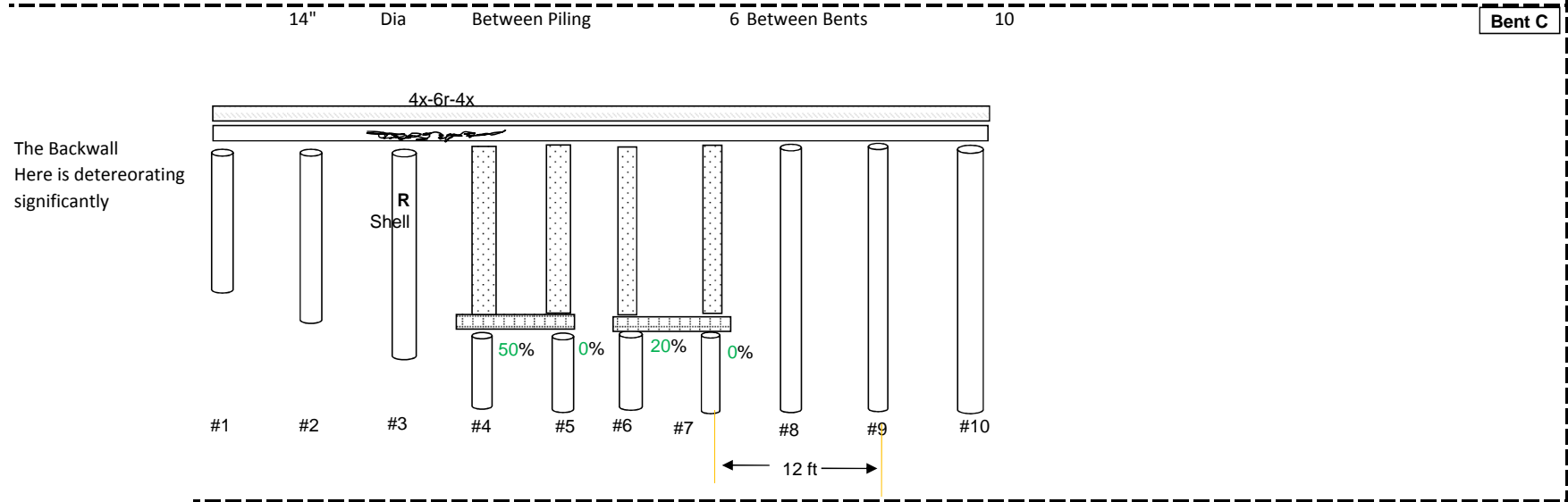
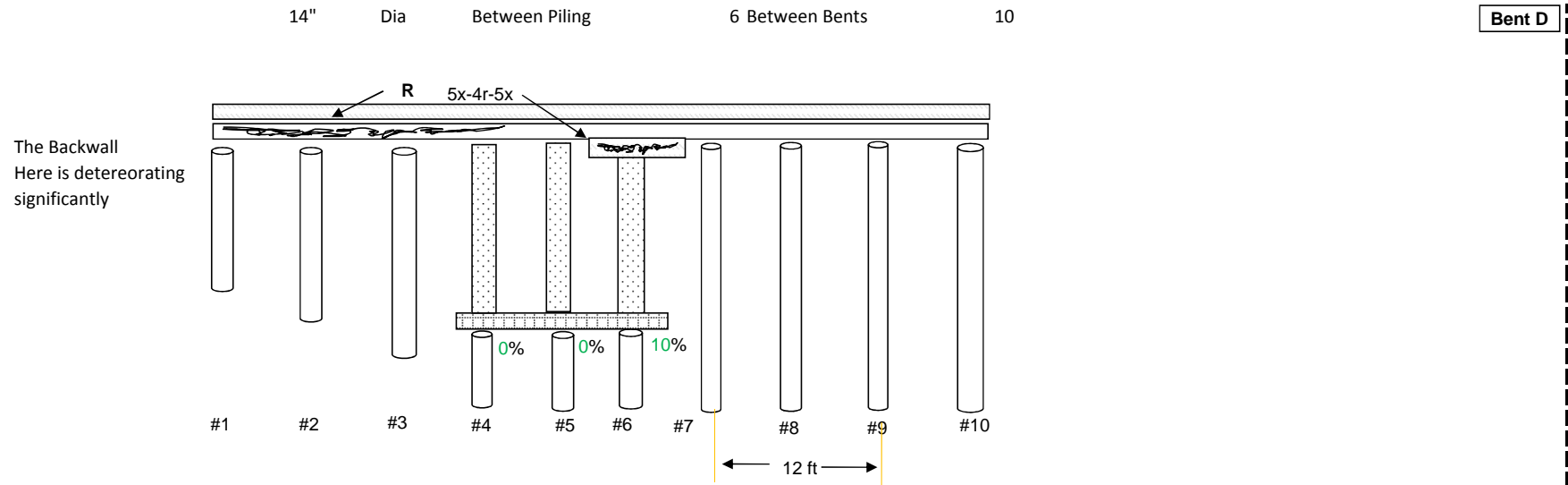

14" Dia Between Piling 6 Between Bents 10

Bent B

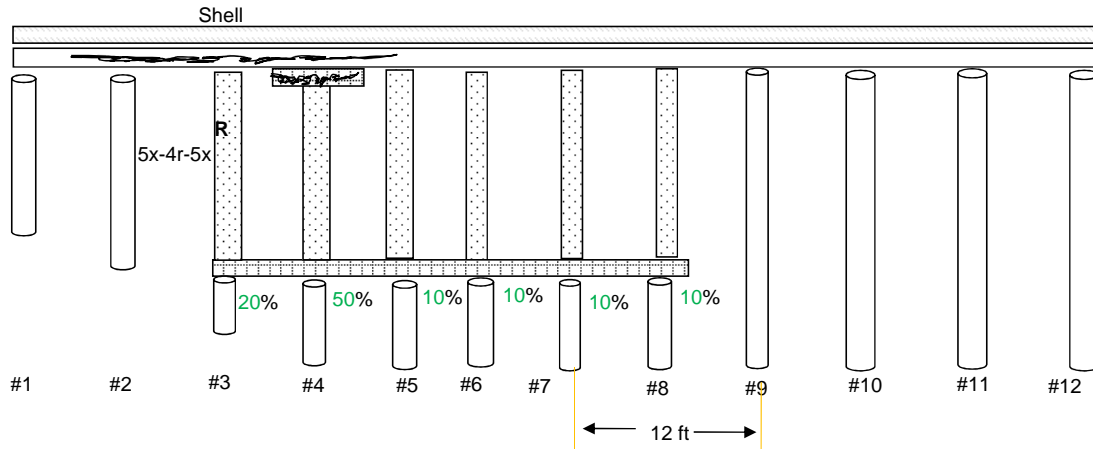

14" Dia Between Piling 6 Between Bents 10

Bent A

Backwall
Corbel
has 6-8" of rot

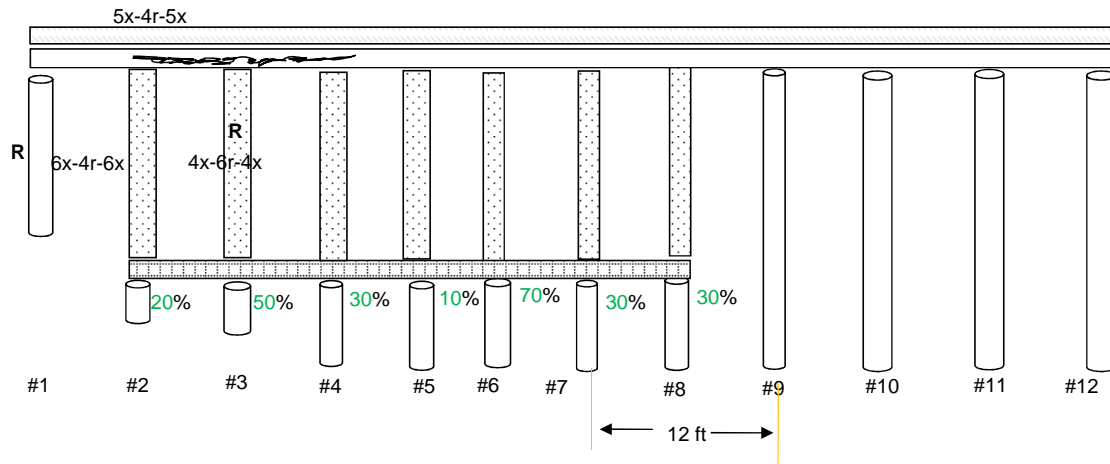

Port of Astoria Pier 2
 Results of Inspection 9/2015 & 1/2016

Cross Bracing & Girders generally not pictured
 3-4 girders per pile. Girders are 13.5" x 6"
 Caps are 14" x 14"

Blue Bearing Loss
 Red Section Loss
 #22527 2/3

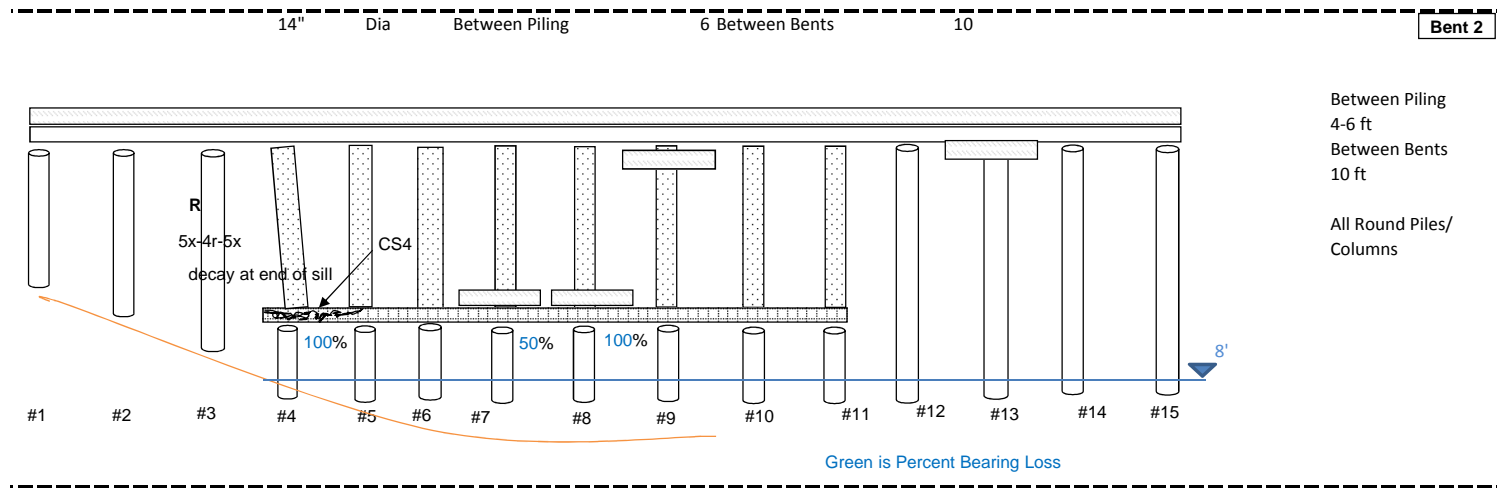
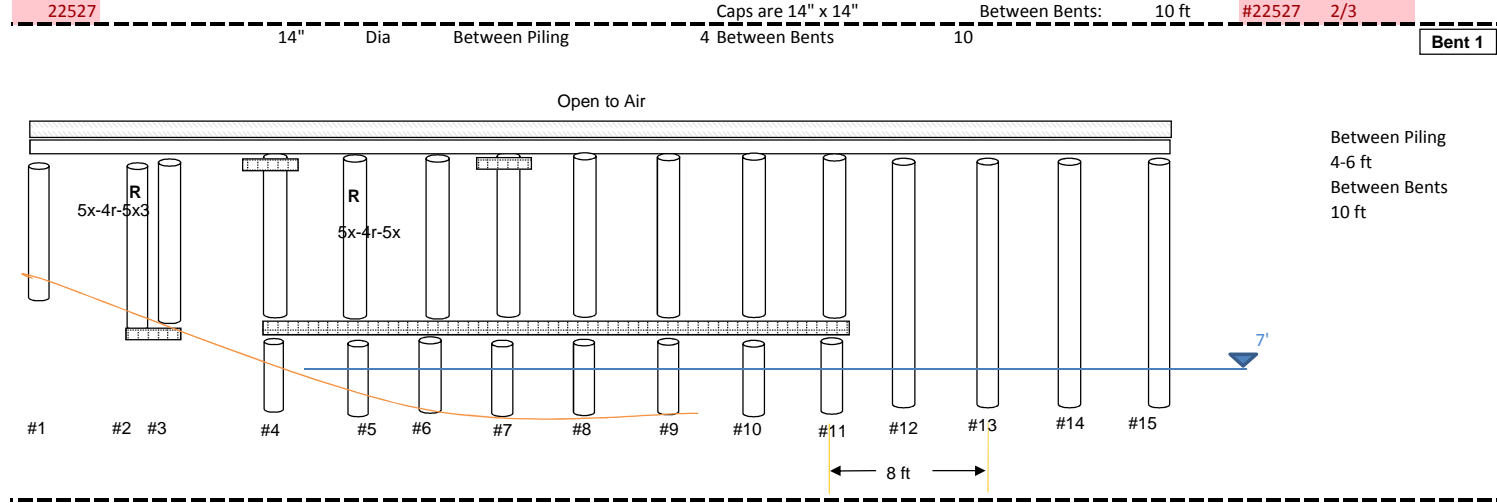

Bent 3

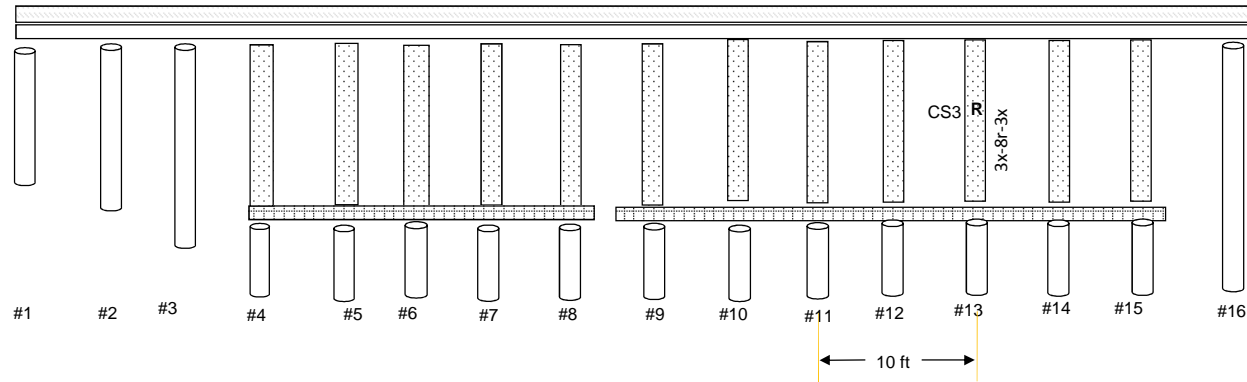

Between Piling
5 ft
Between Bents
10 ft

All Round Piles/
Columns

Bent 4

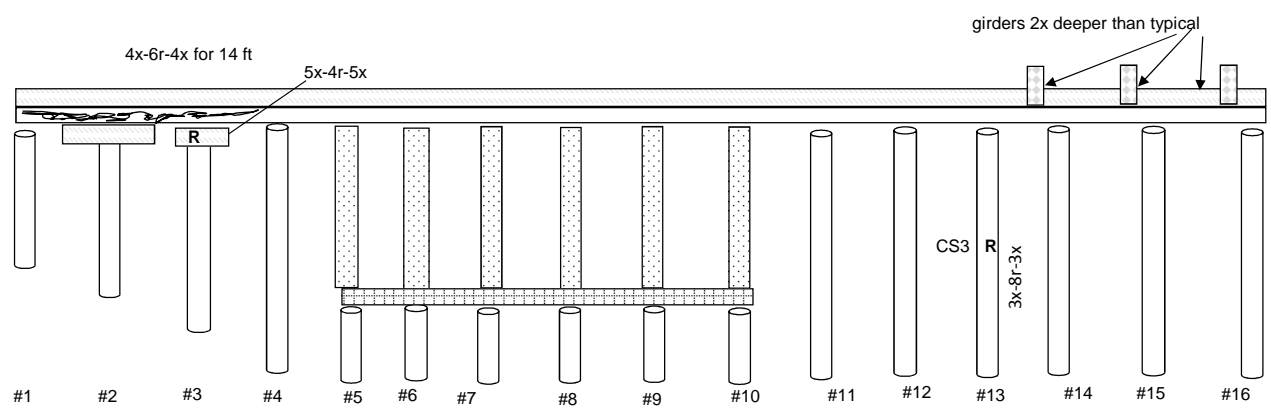

Between Piling
5 ft
Between Bents
10 ft

All Round Piles/
Columns

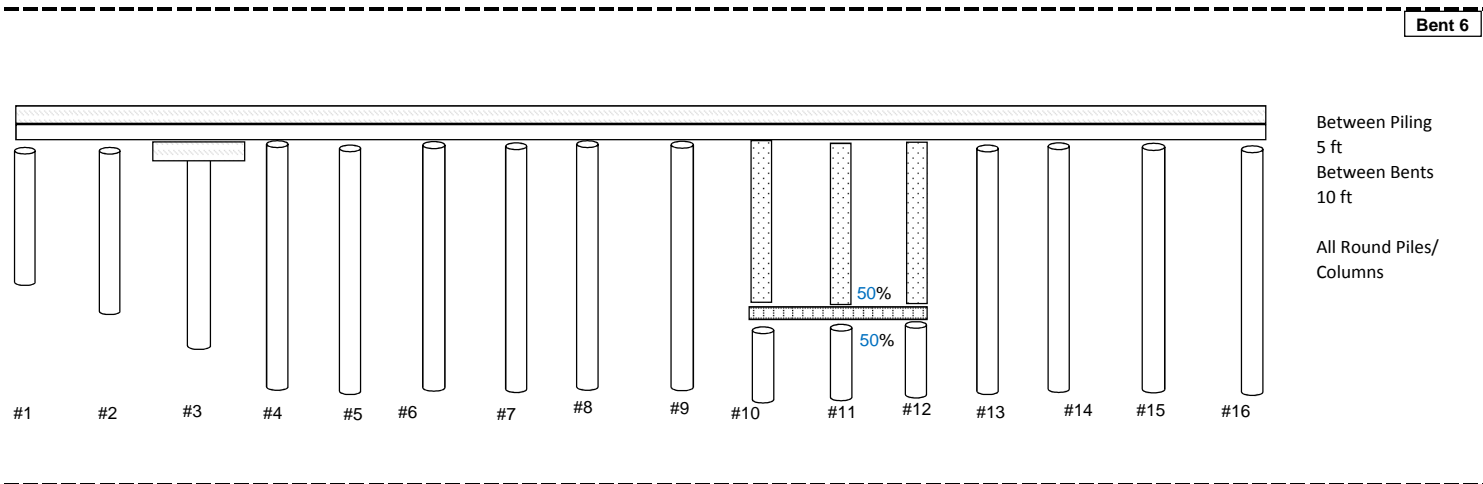
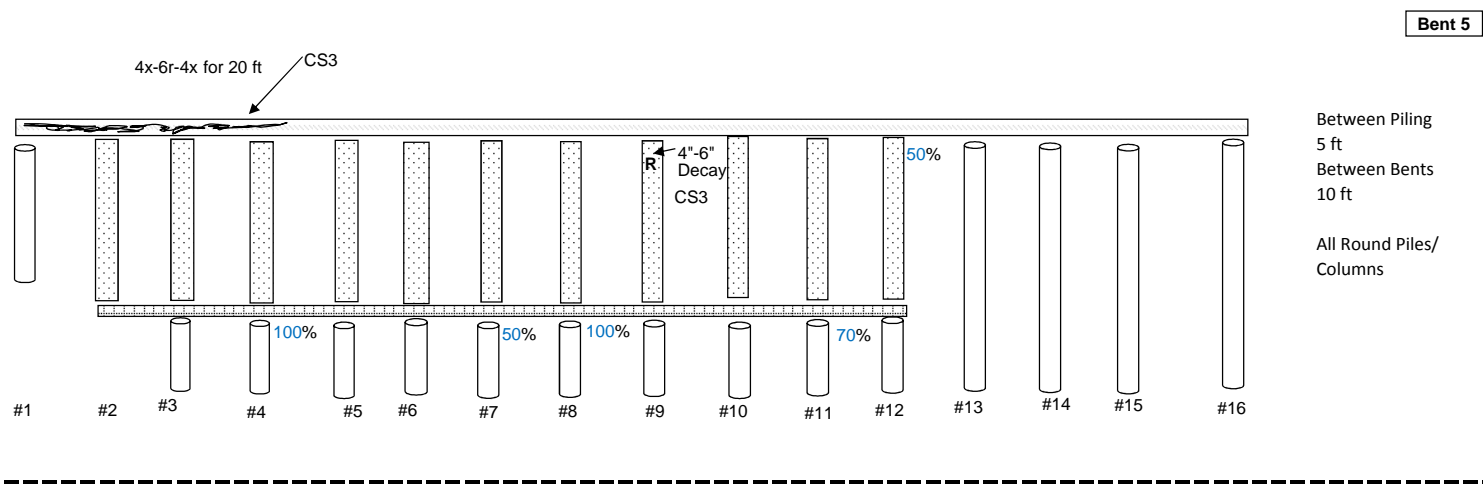

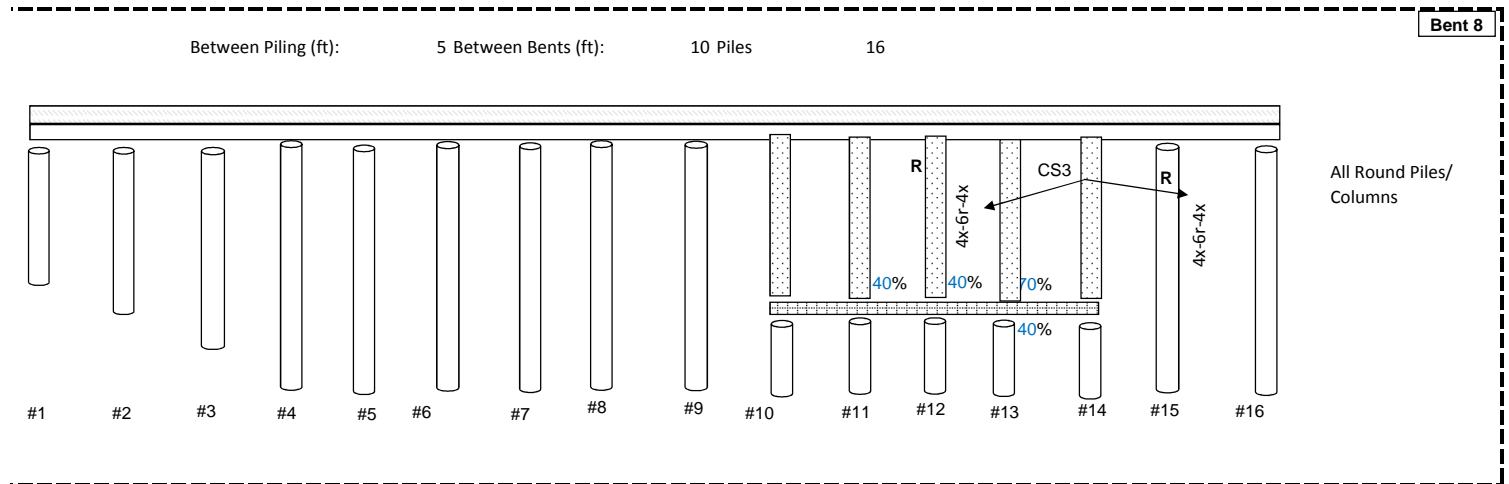
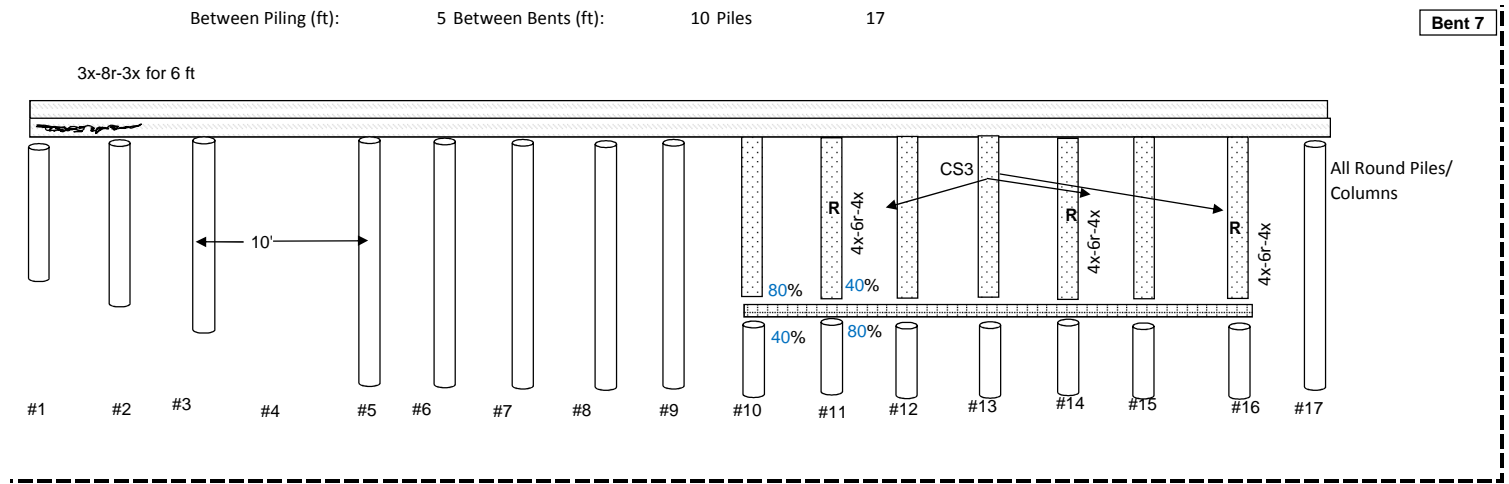

Between Piling (ft):

5 Between Bents (ft):

10 Piles

17

Bent 9

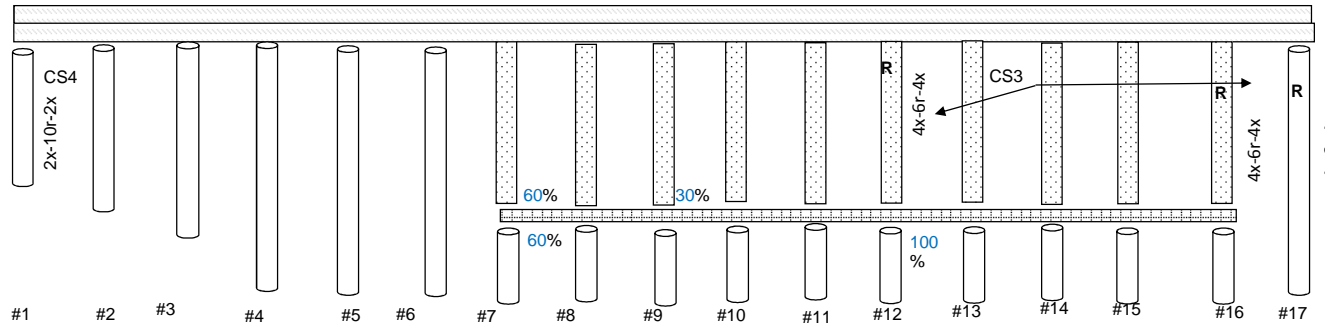

Between Piling (ft):

5 Between Bents (ft):

10 Piles

16

Bent 10

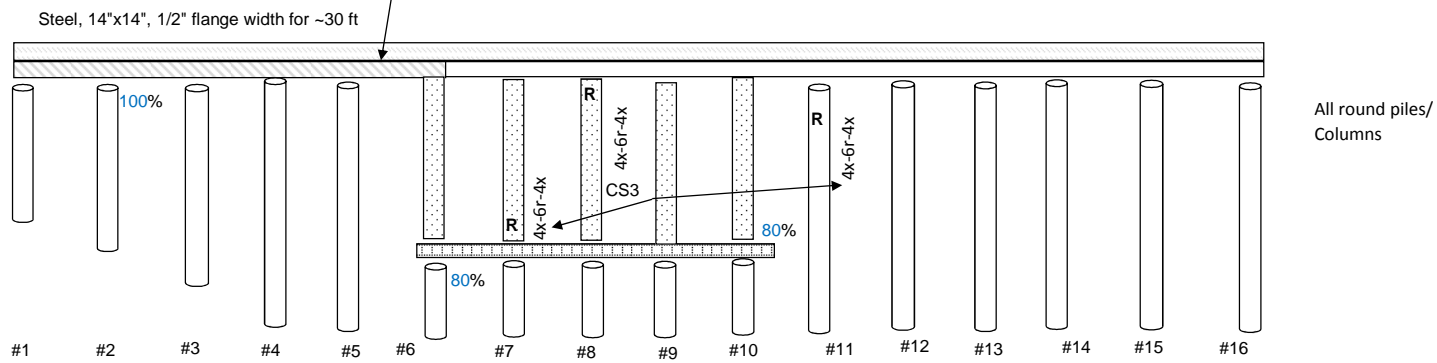

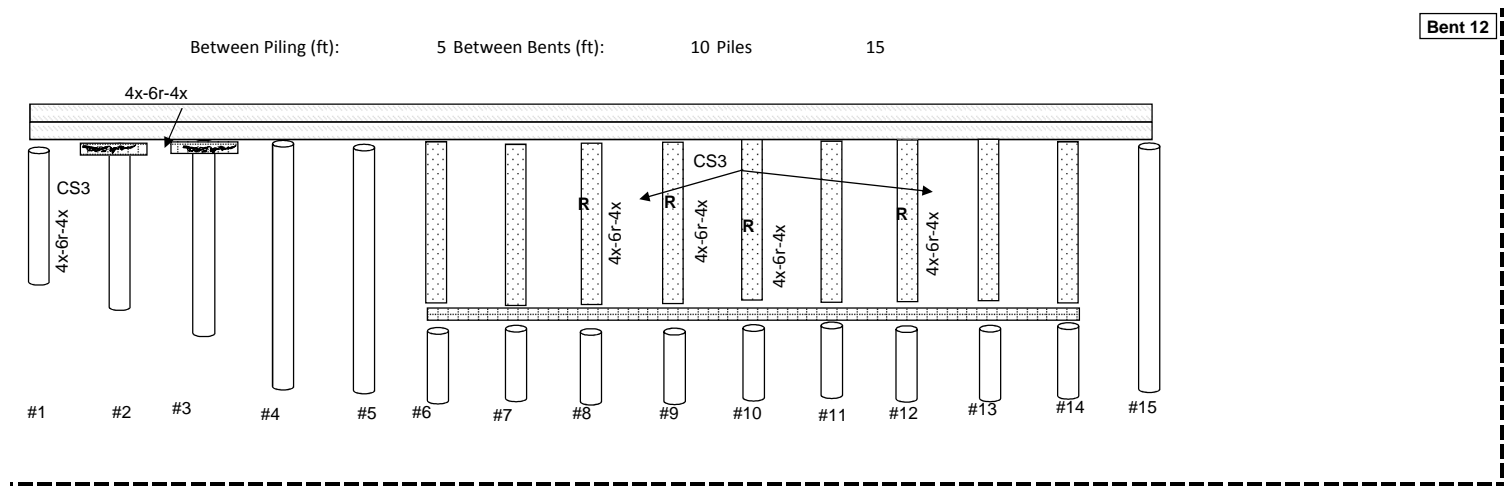
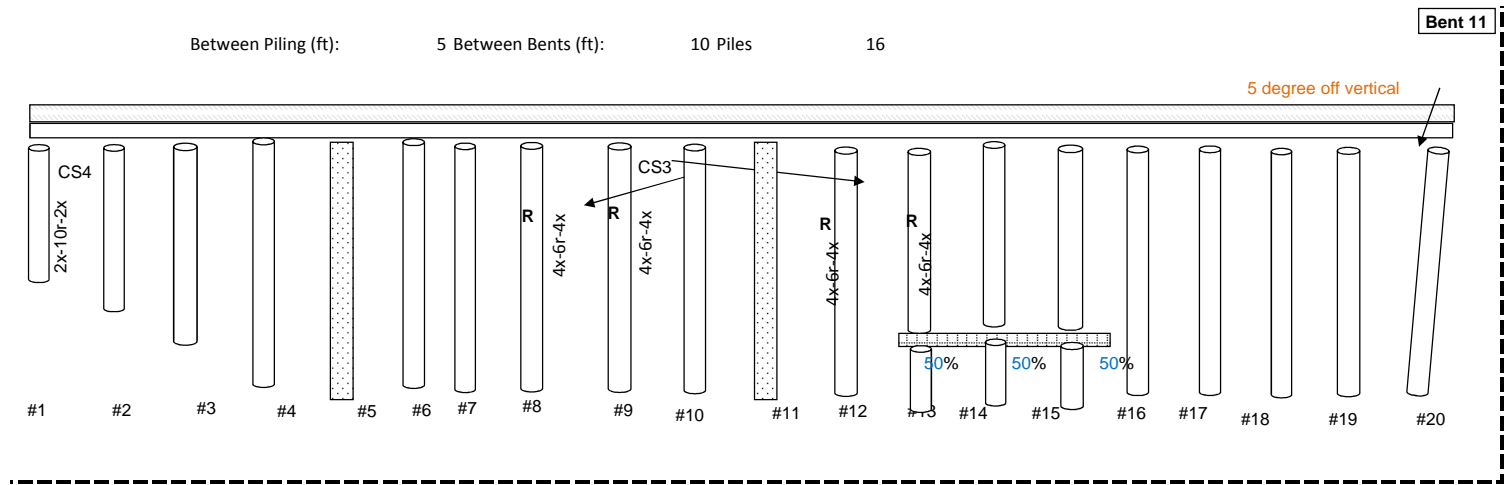

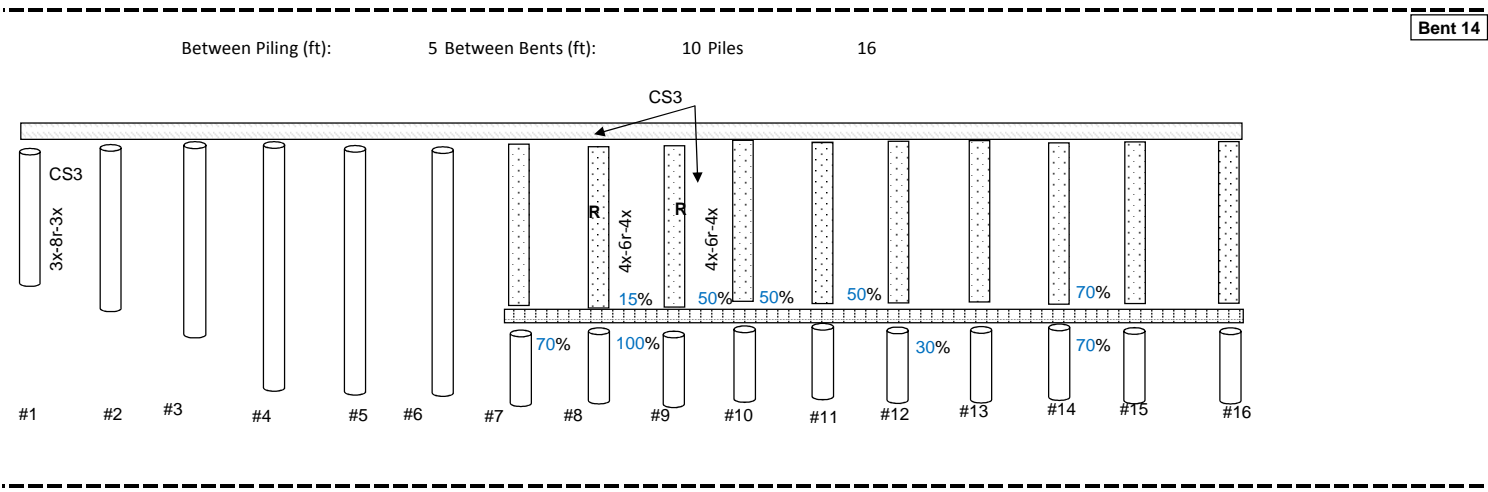
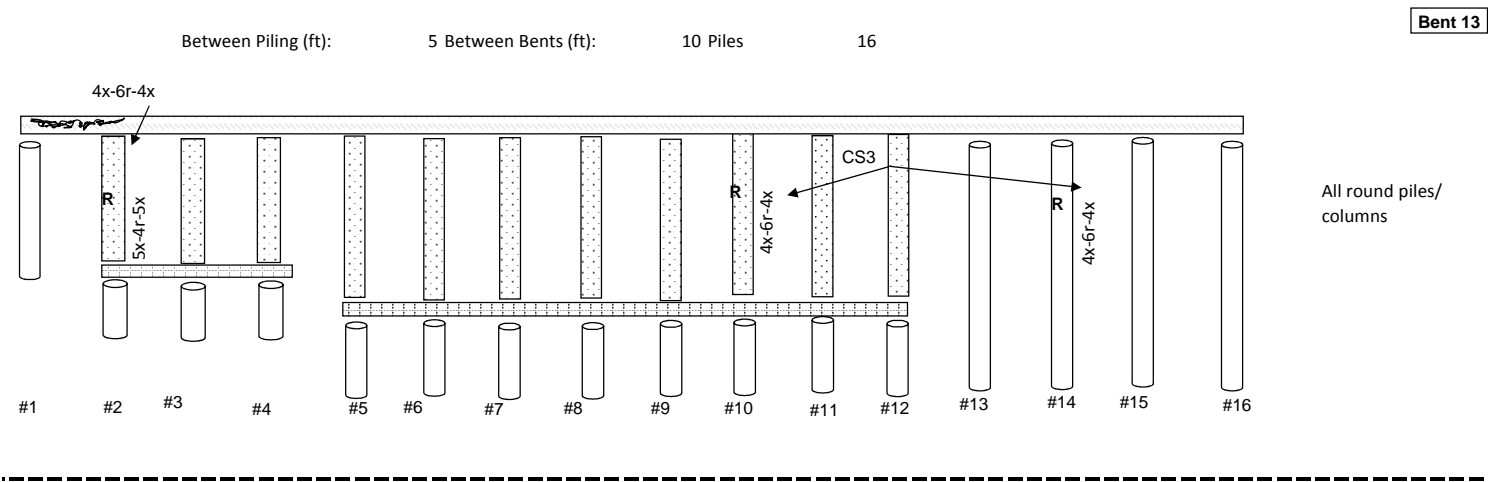

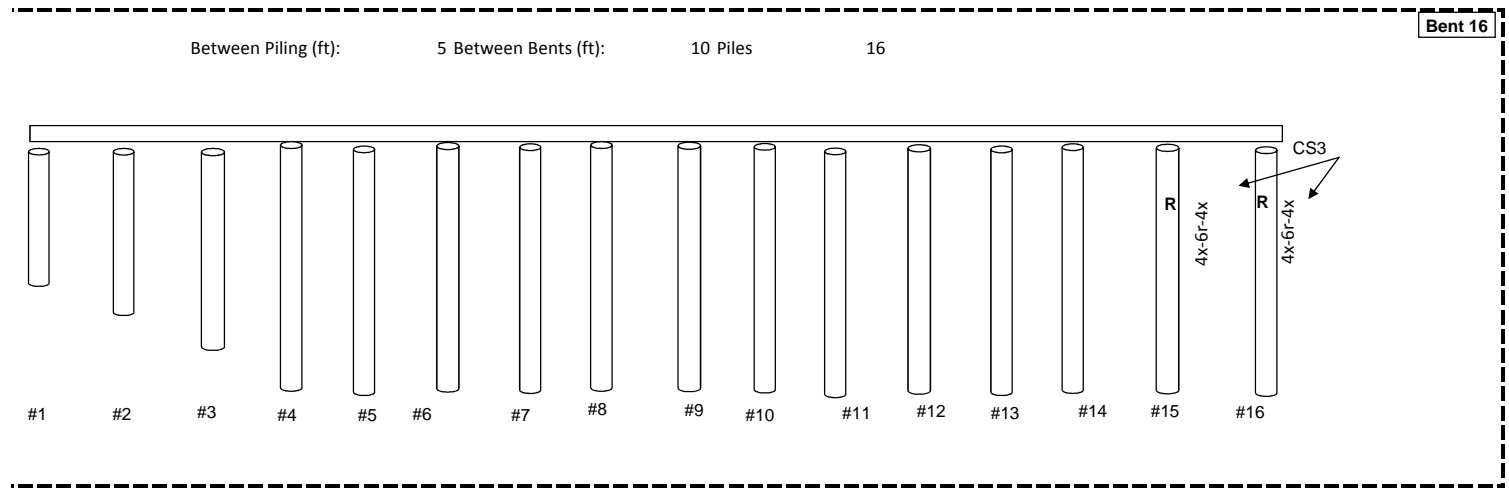
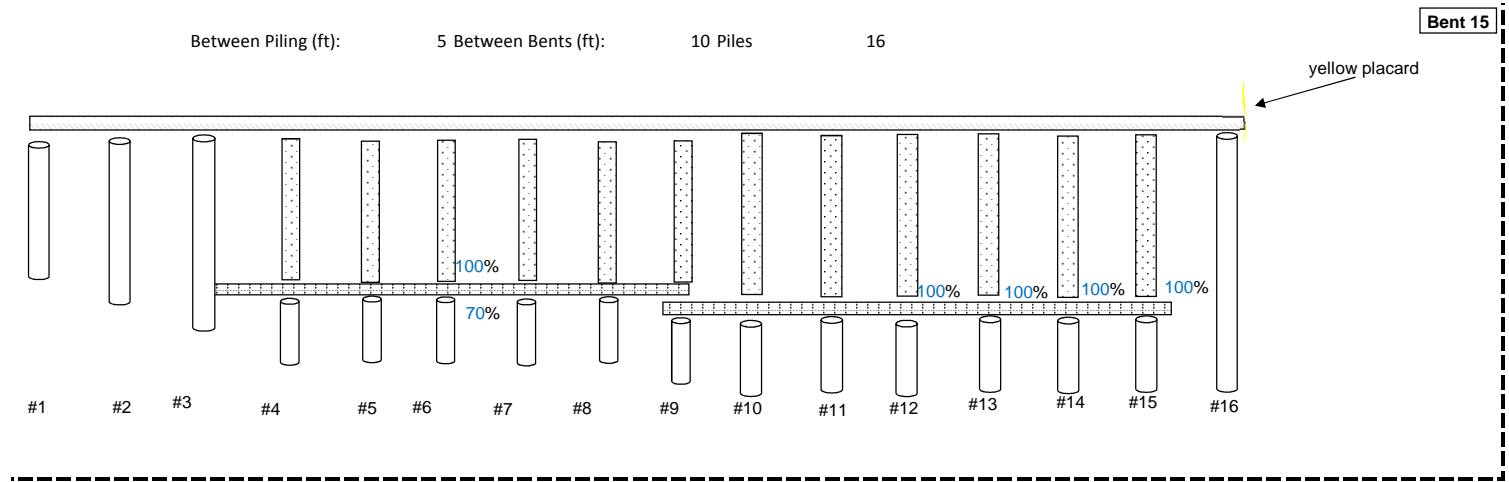

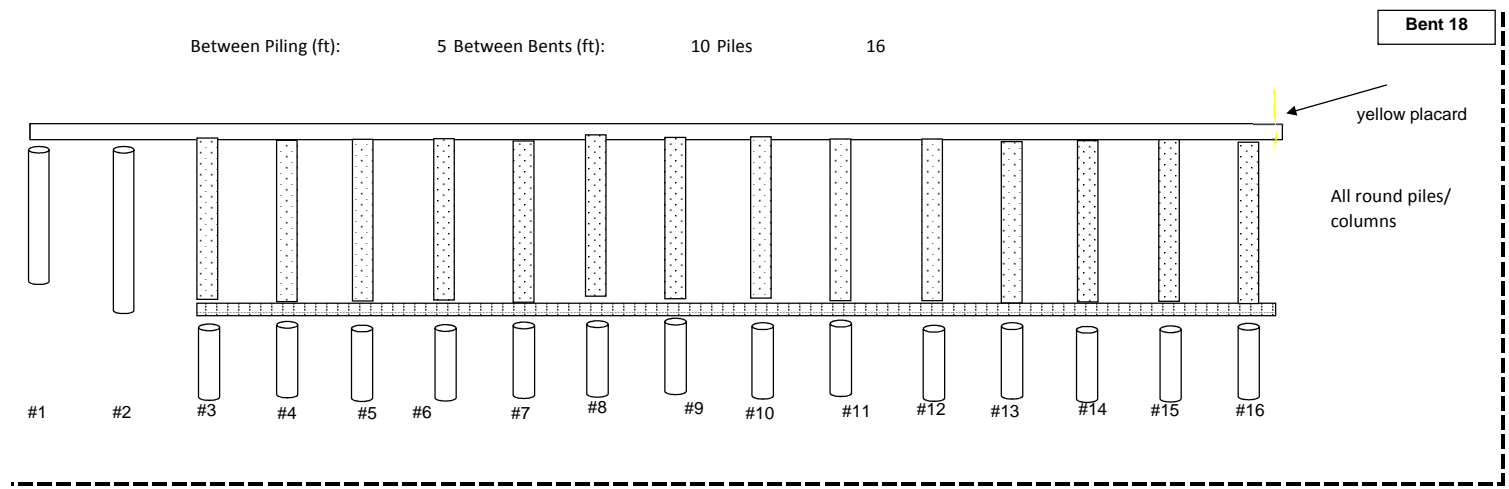
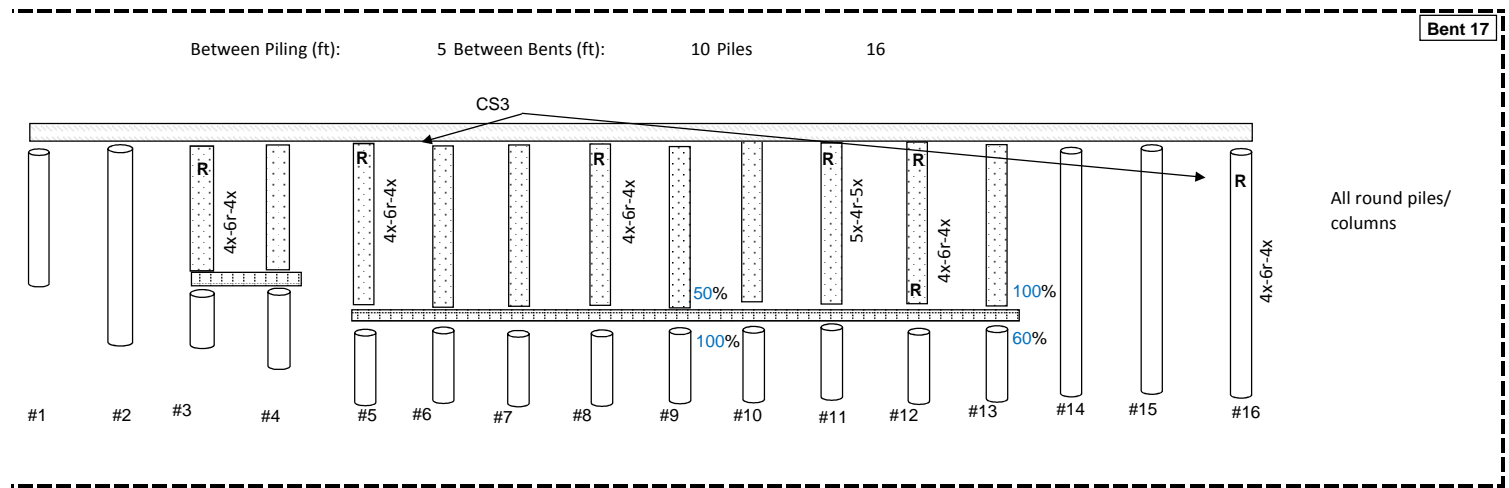

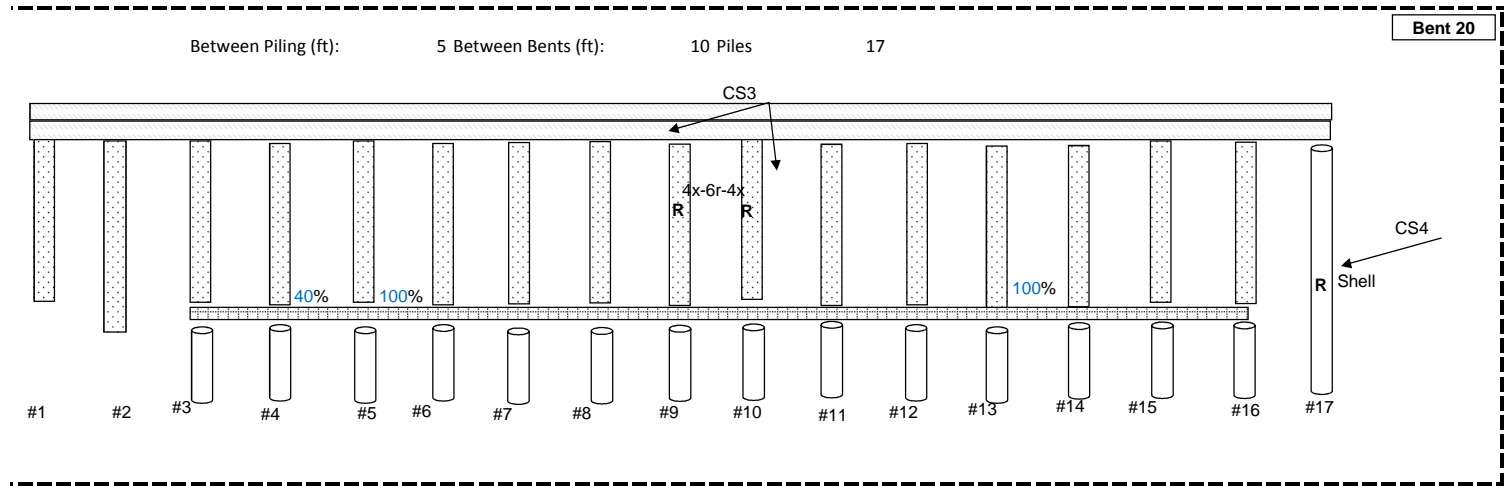
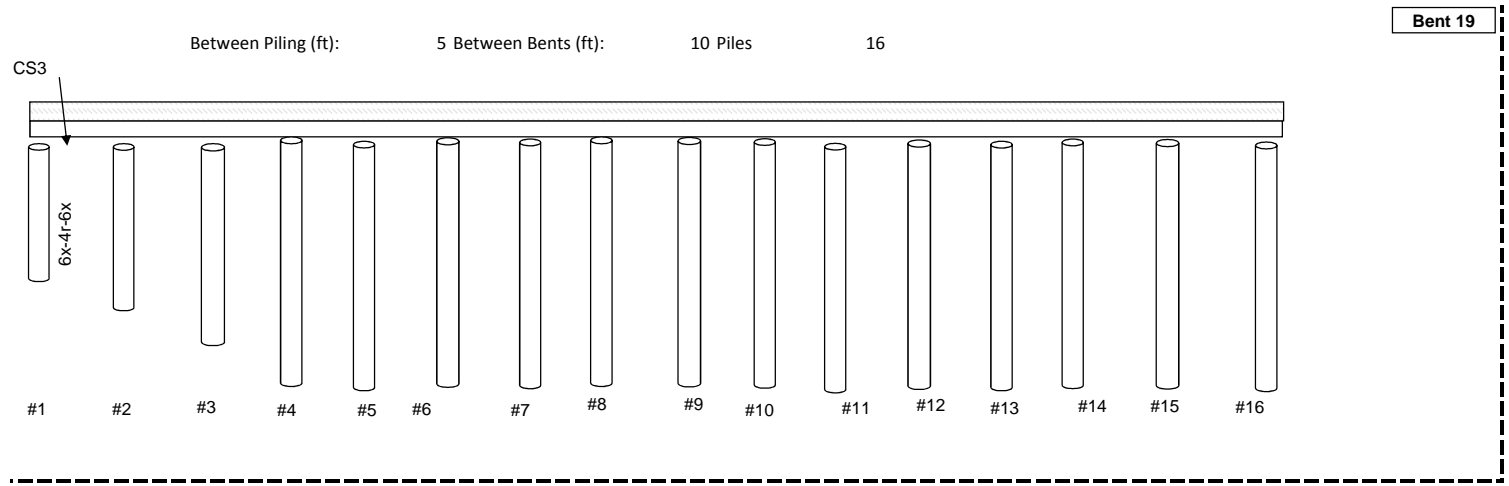

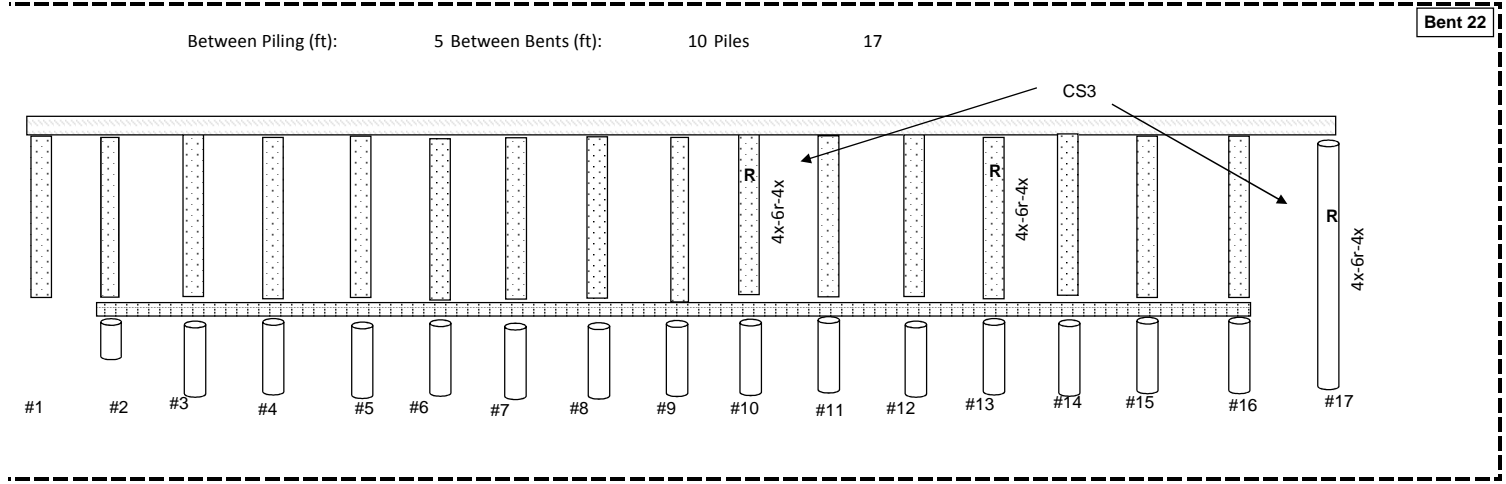
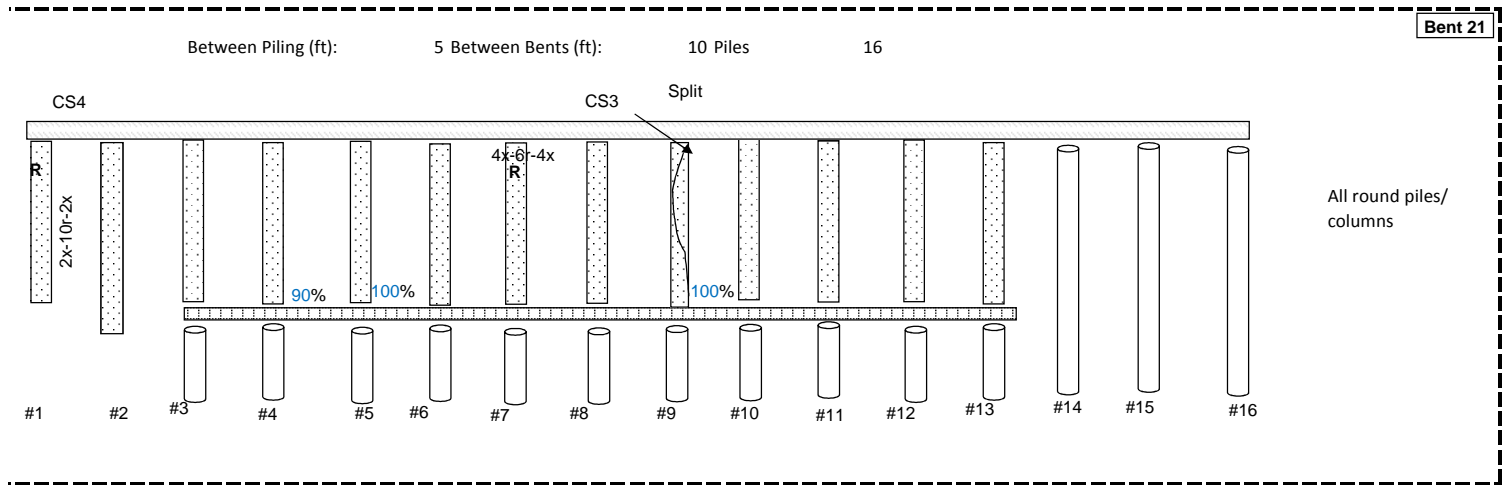

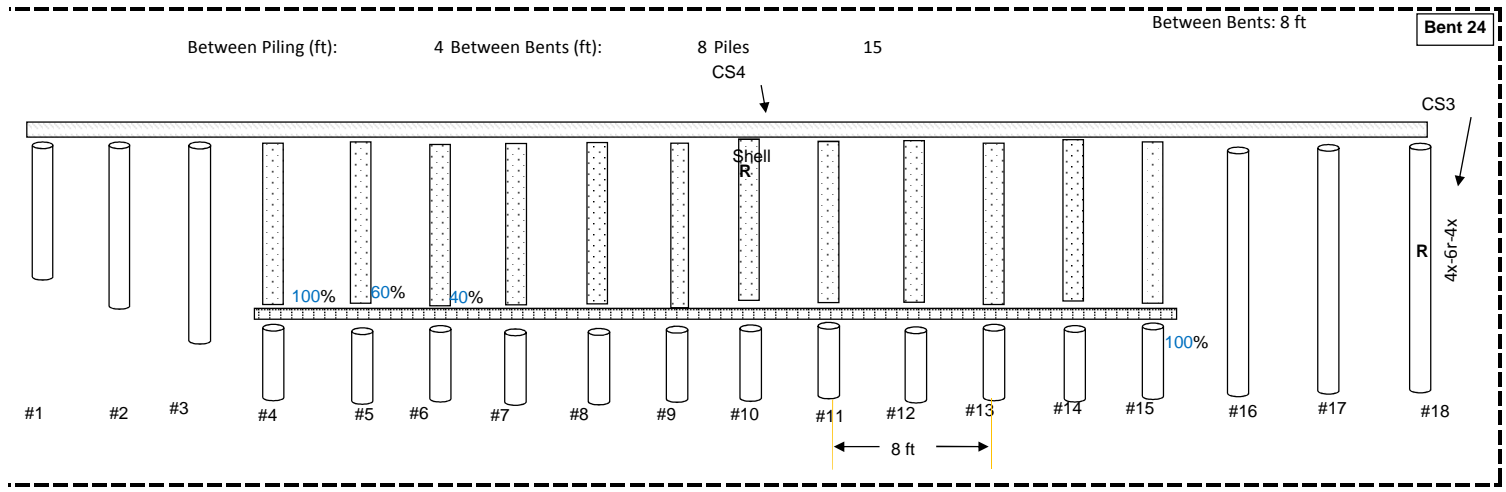
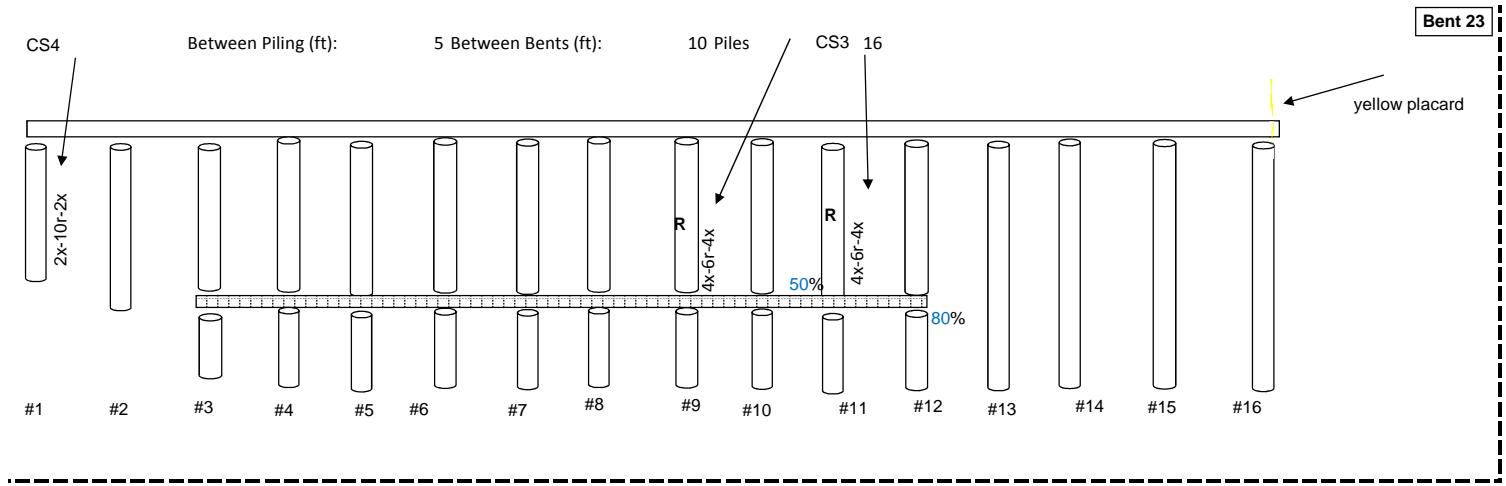

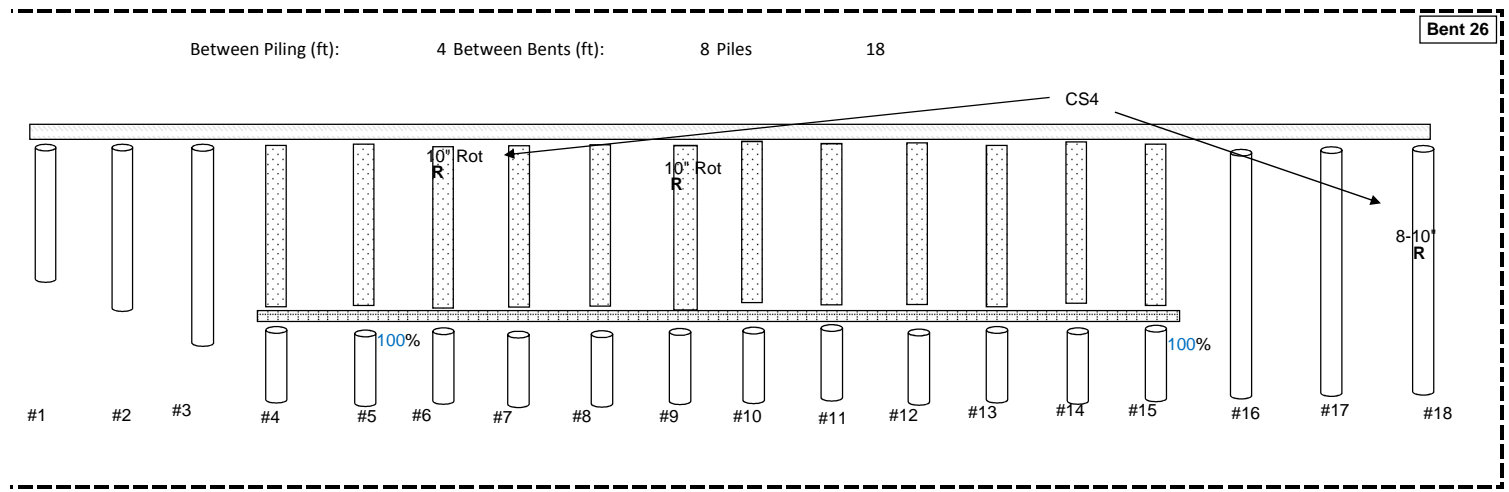
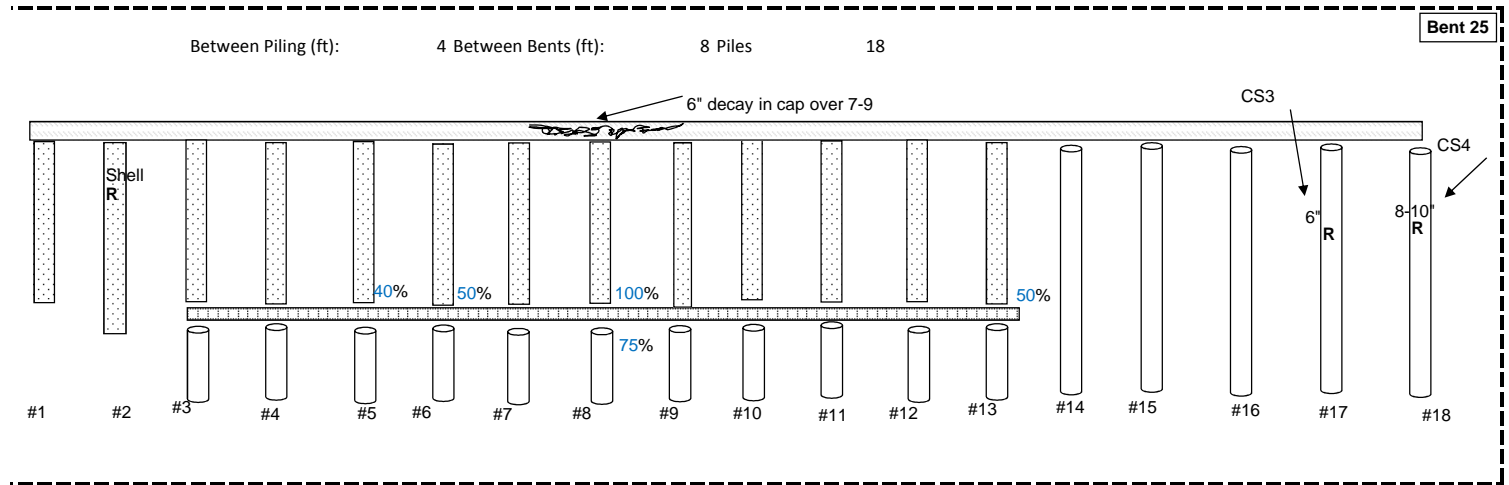

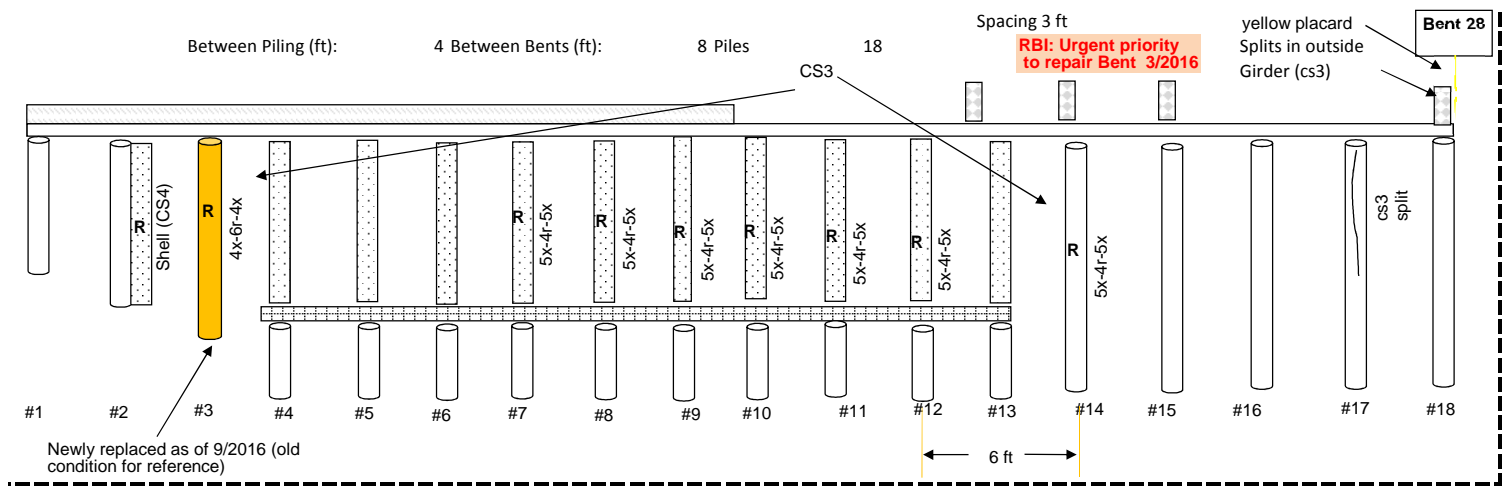
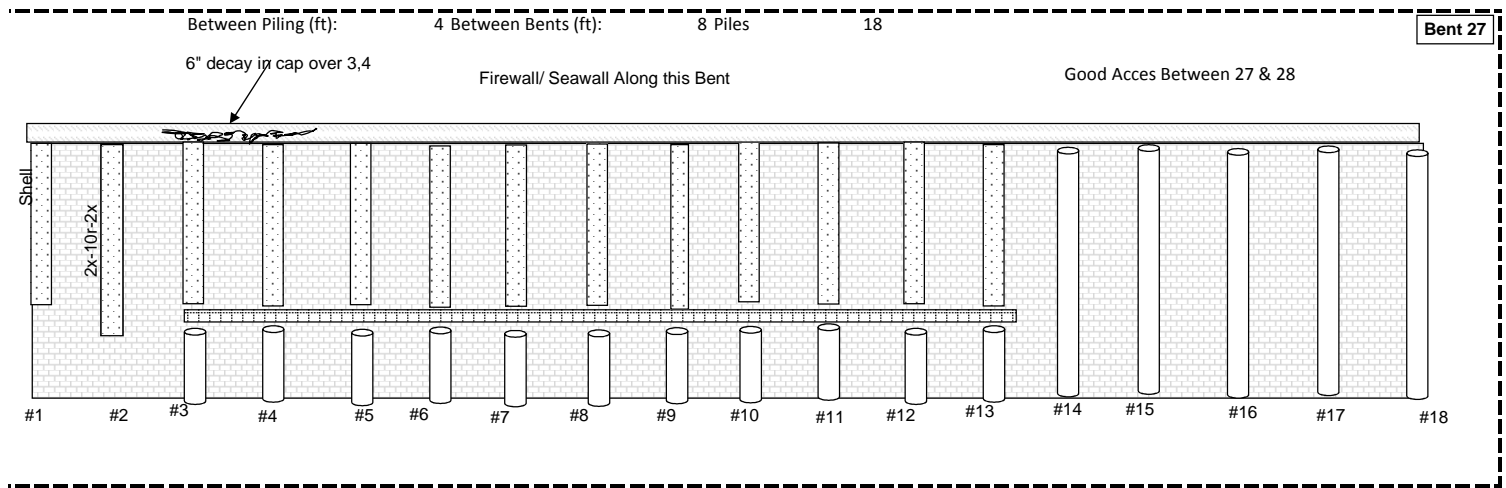

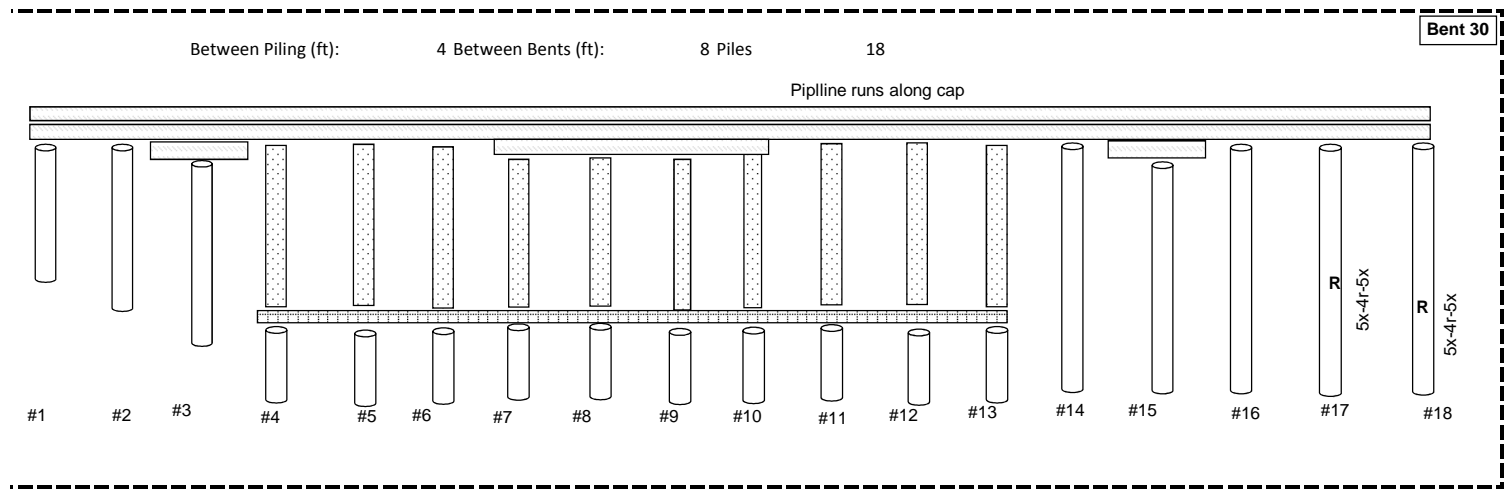
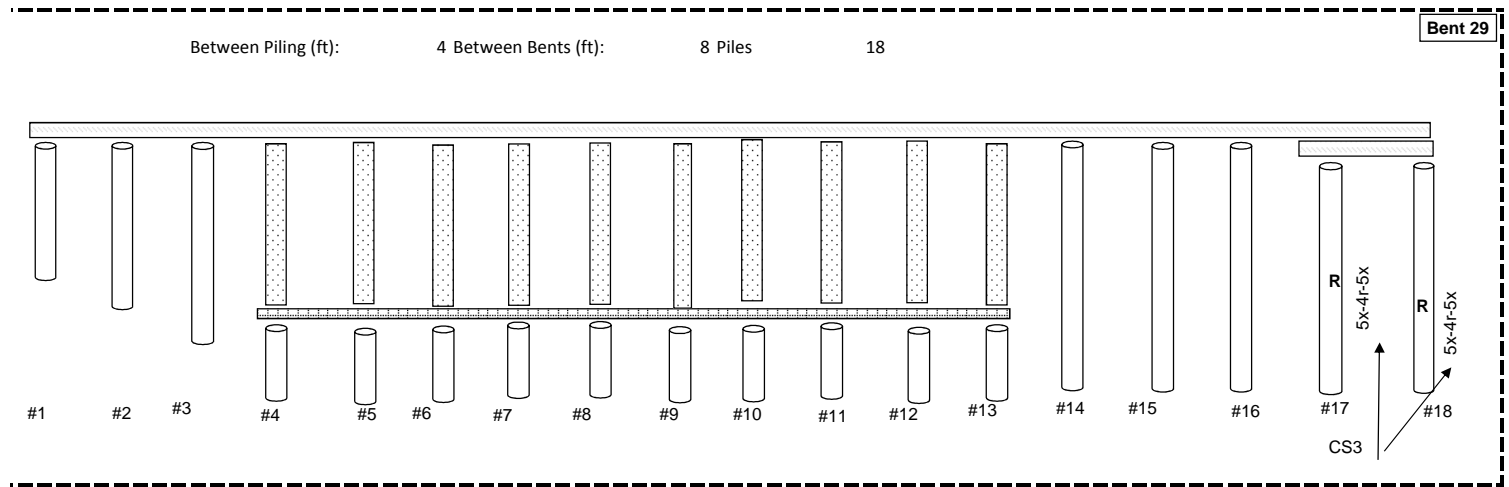

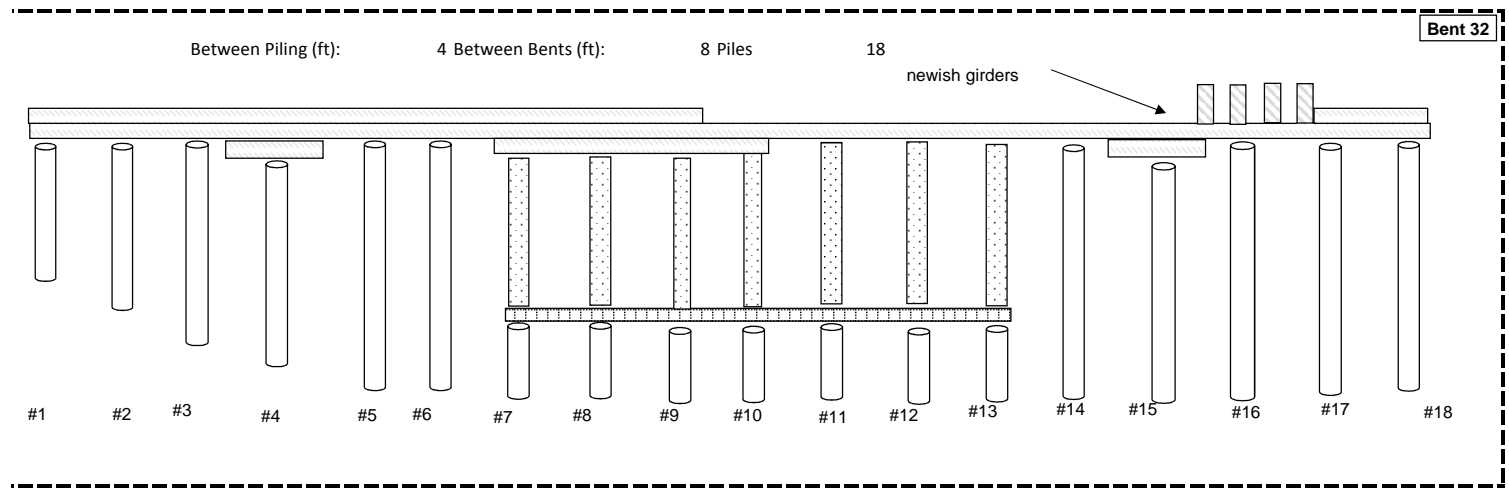
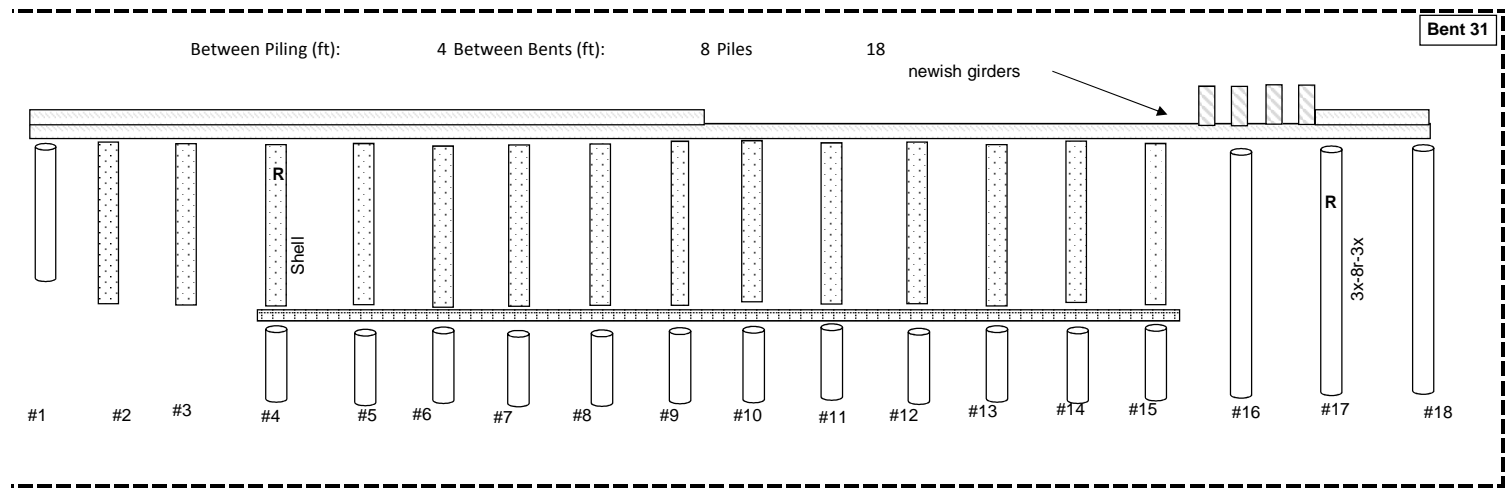

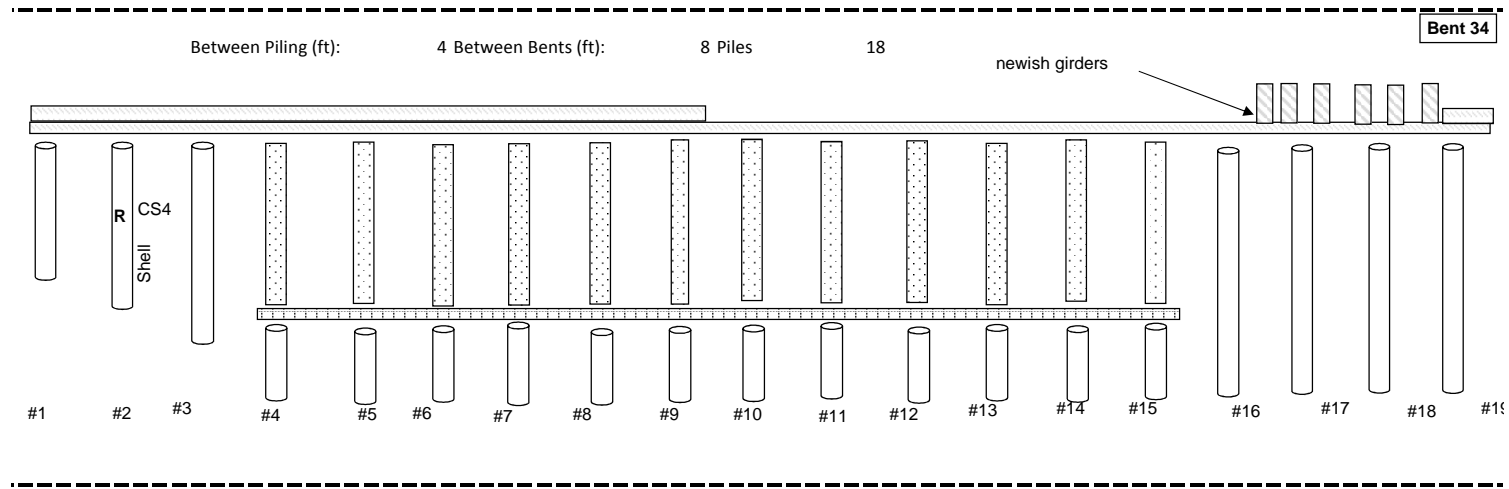
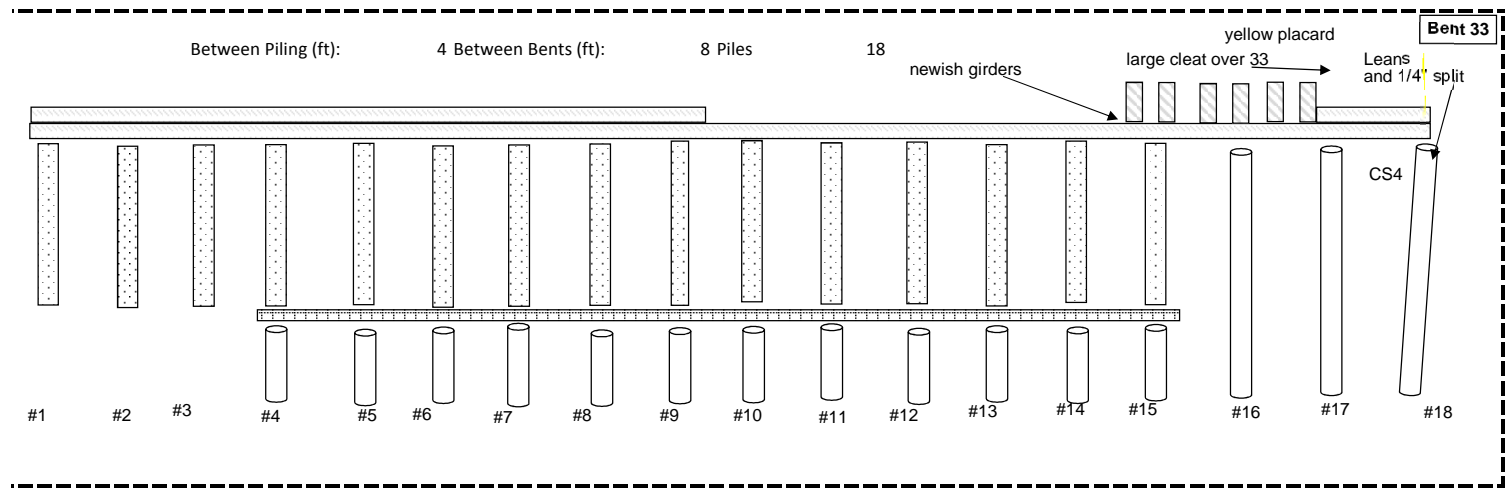

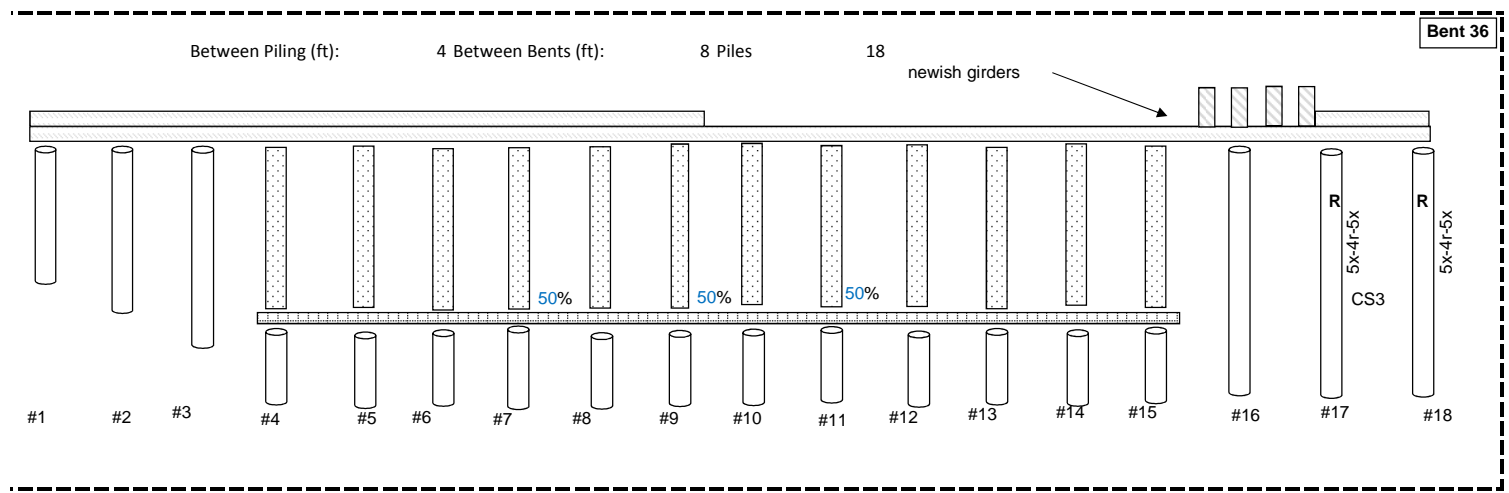
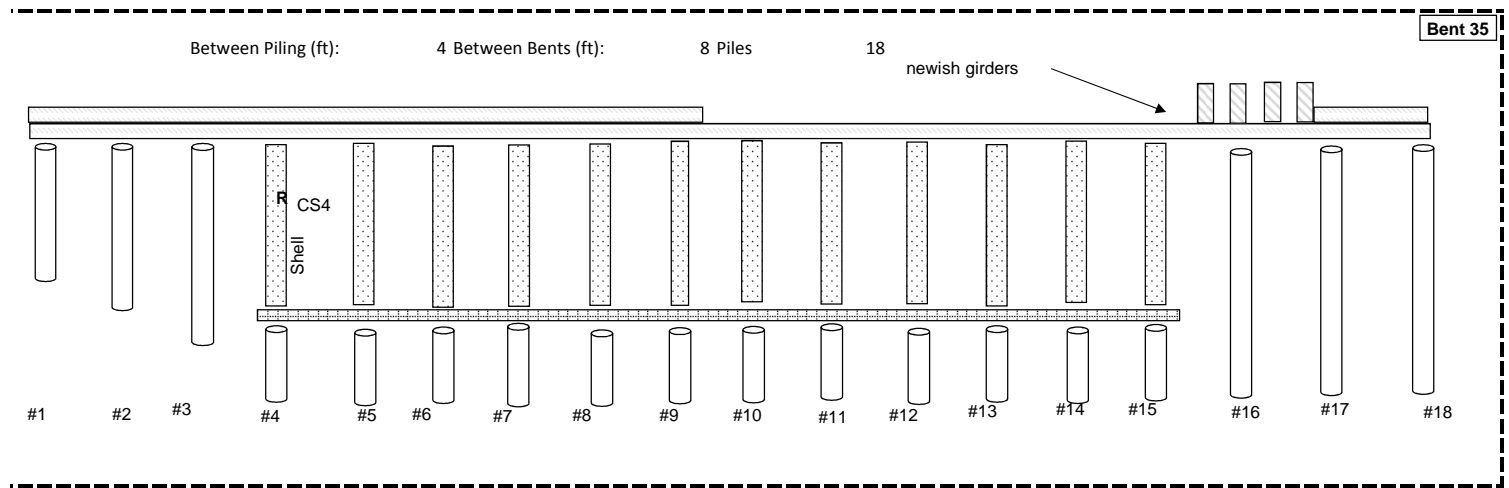

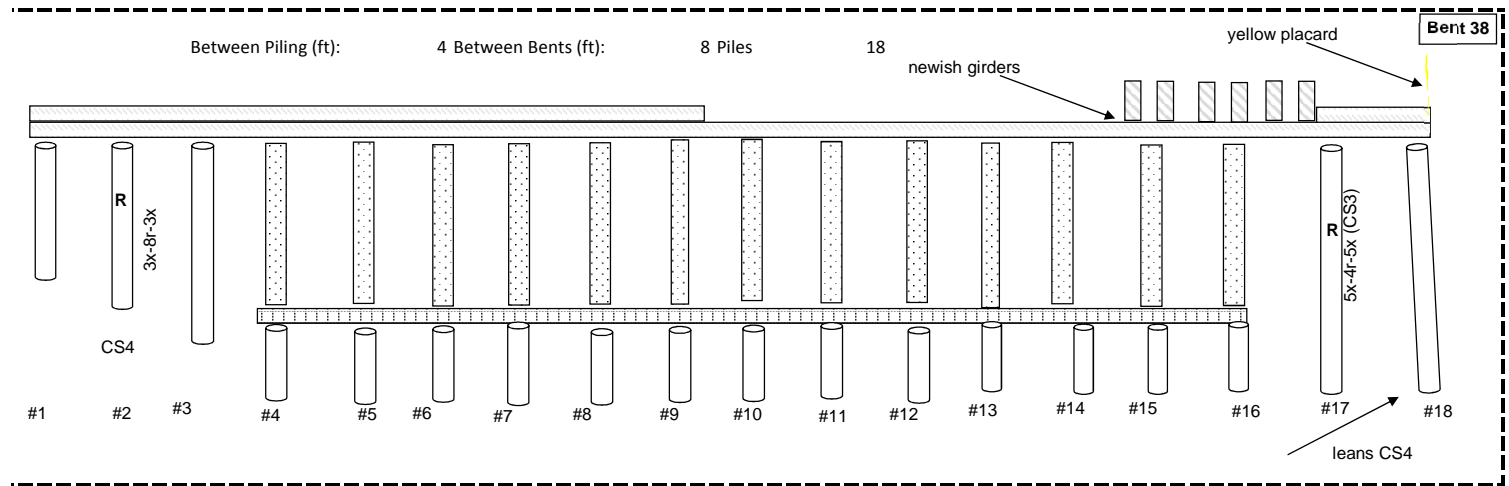
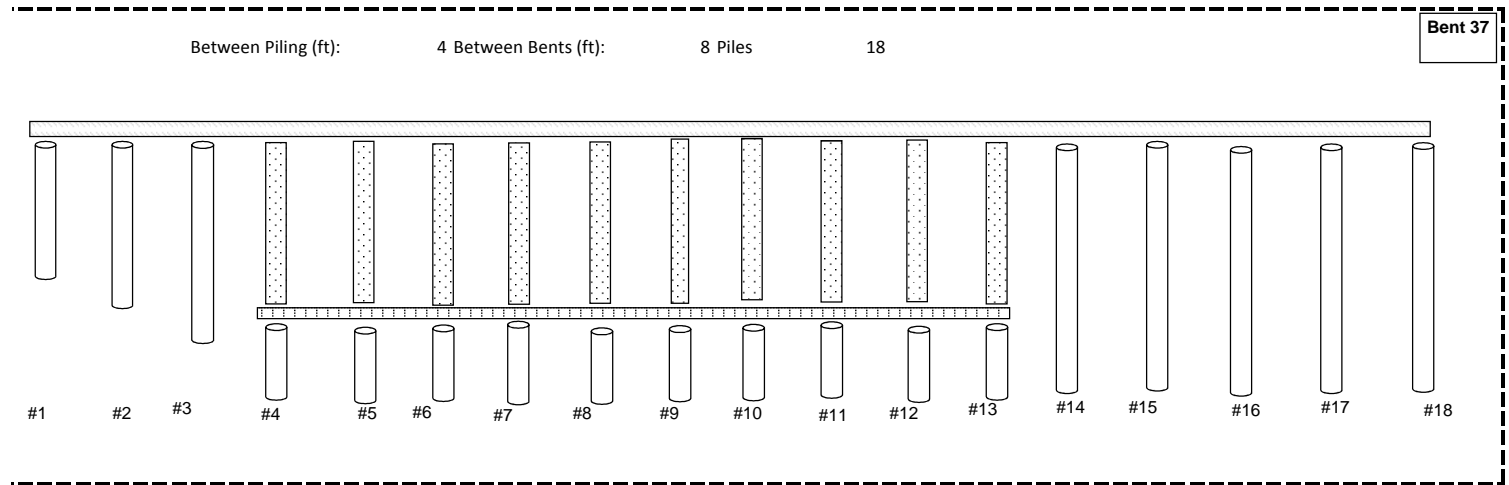

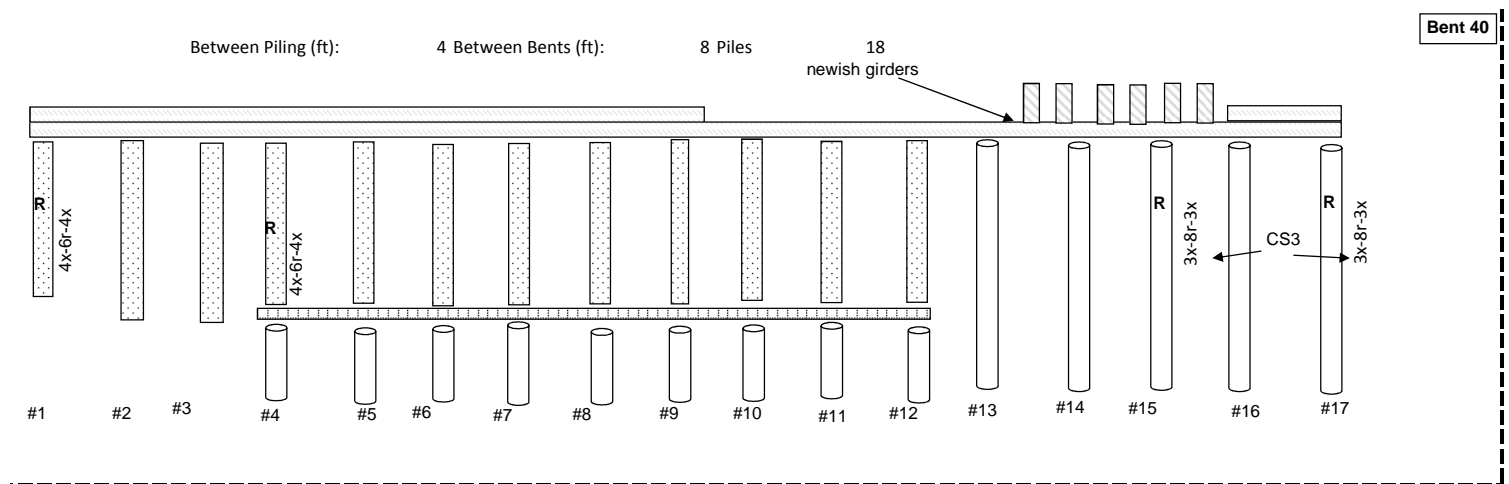
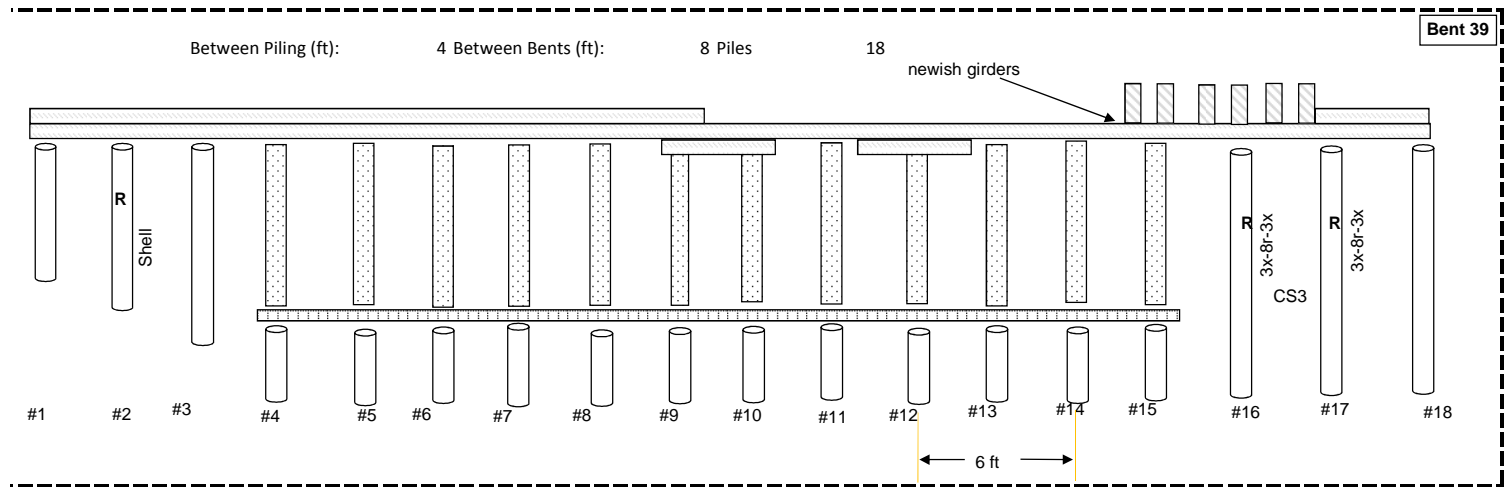

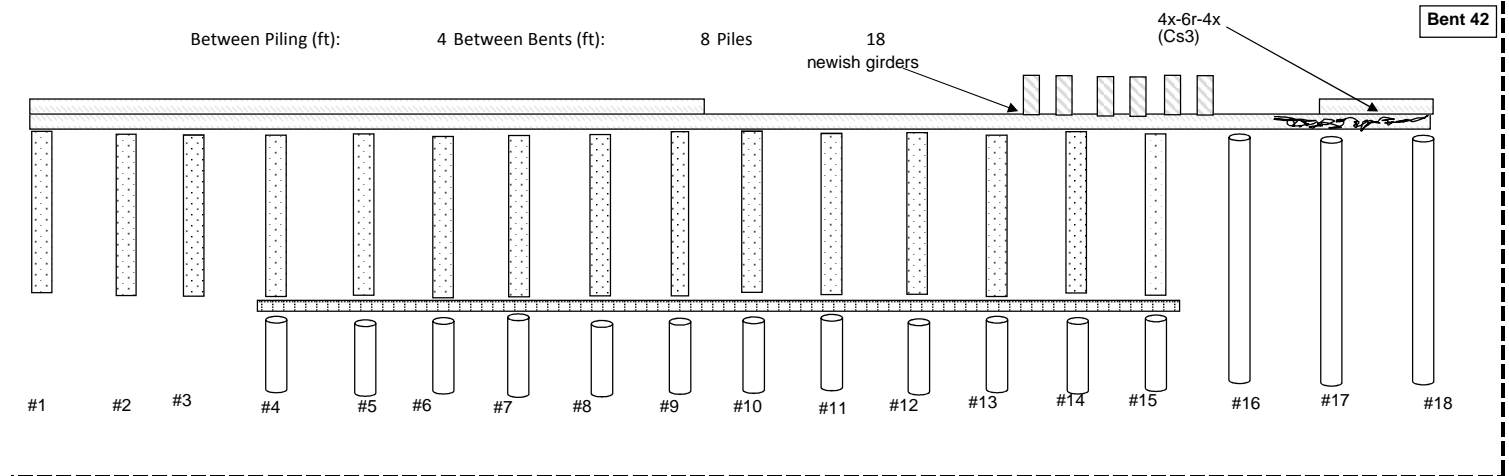
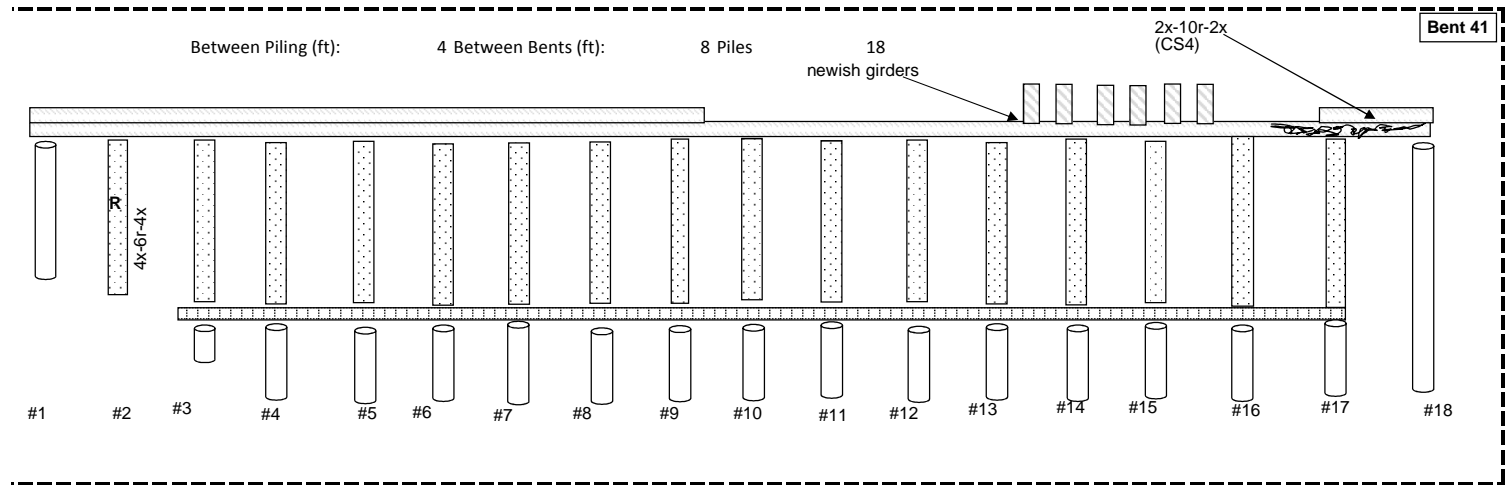

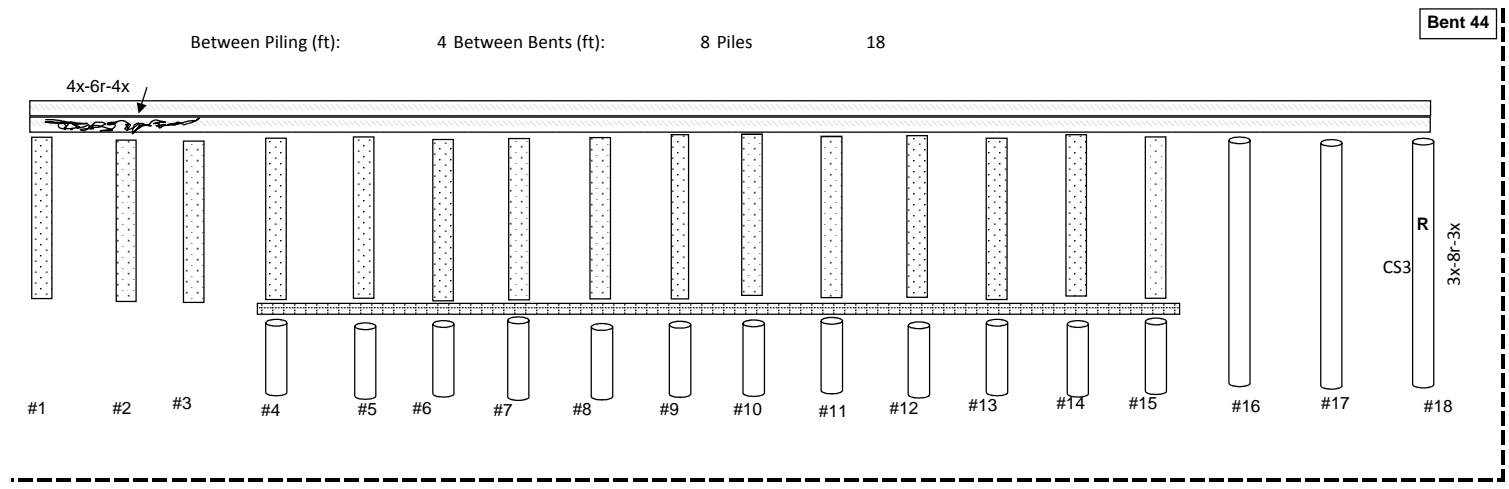
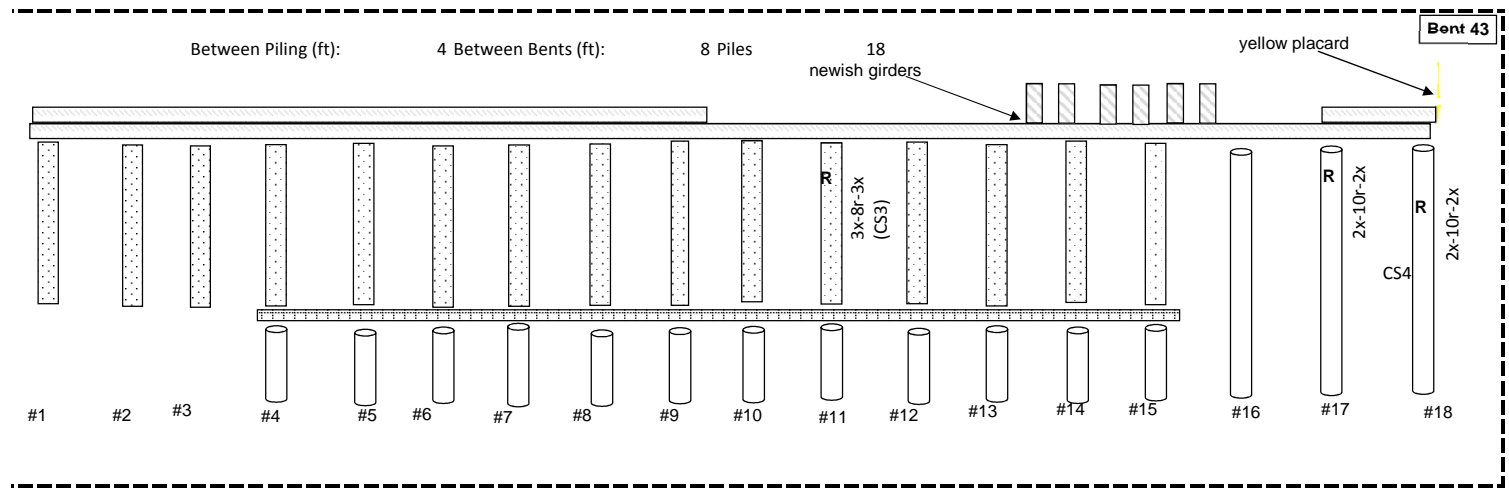

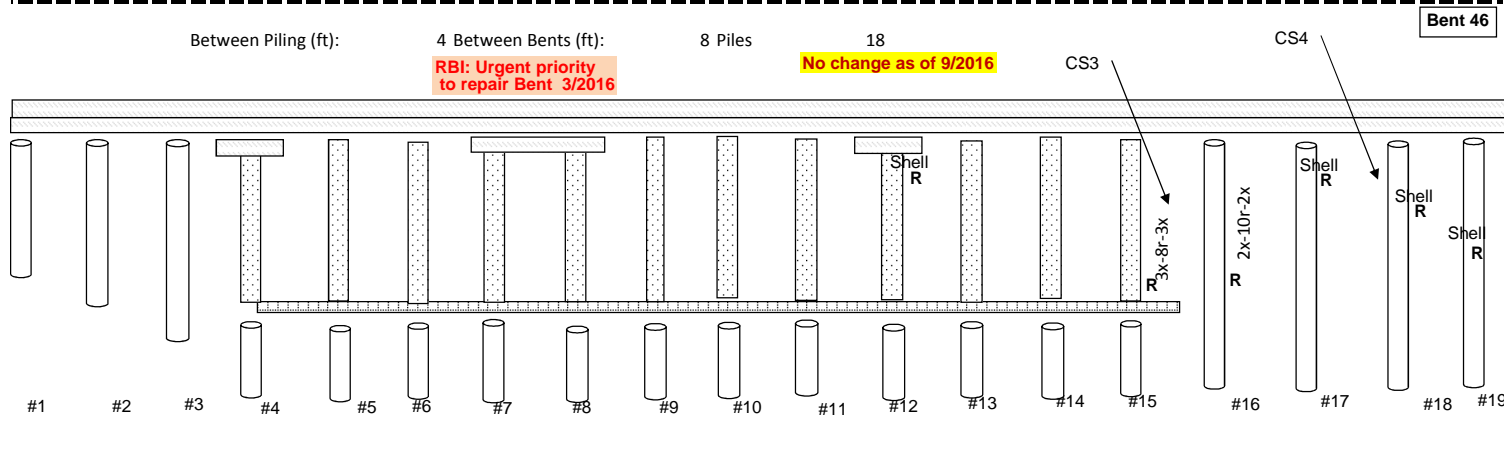
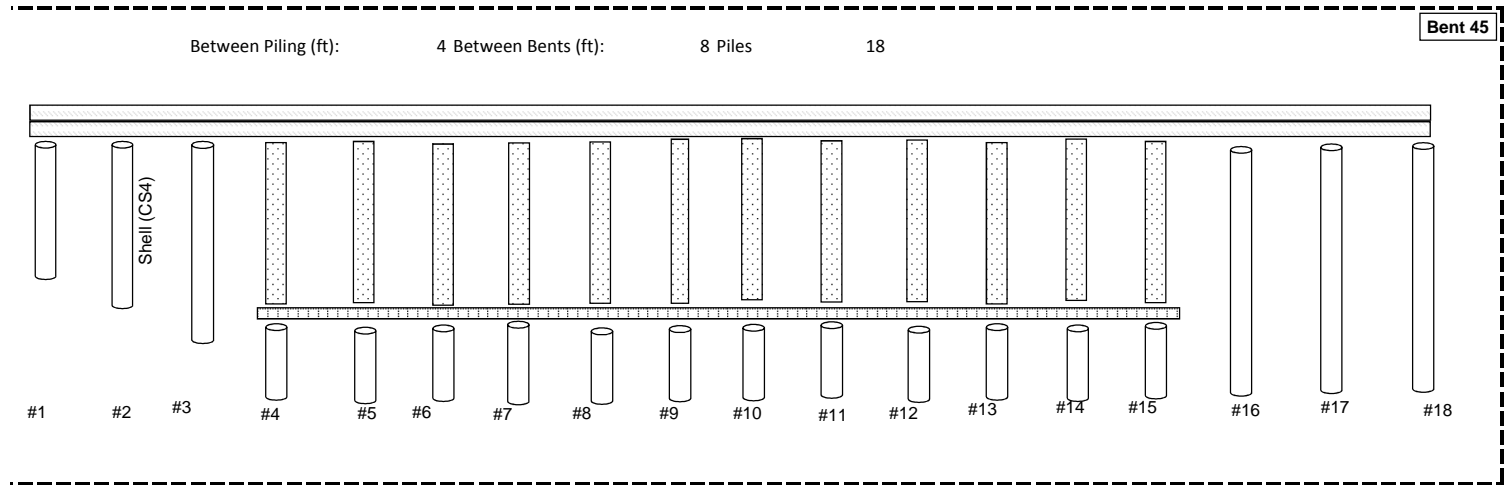

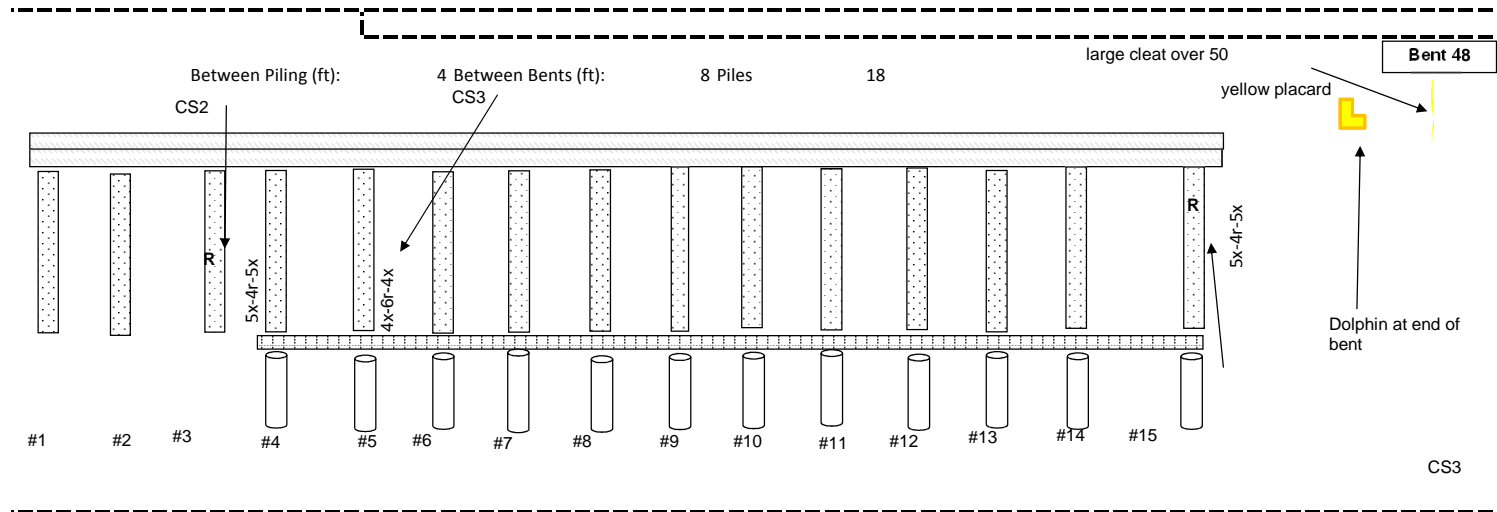
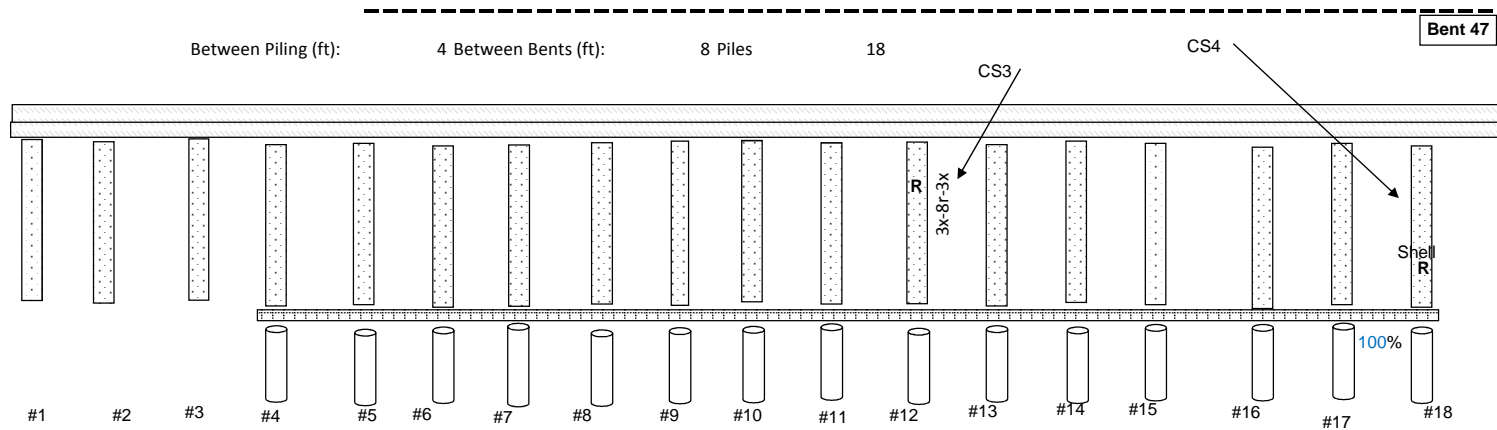

Port of Astoria Pier 2
 Results of Inspection 9/2015 & 1/2016

Cross Bracing & Girders generally not pictured
 Girders (12" x 4") at 16" to 18" O.C. Typical
 Caps are 14" x 14"

Blue Bearing Loss
 Red Section Loss
 #22527 3/3

22527

Between Bents: 8 ft

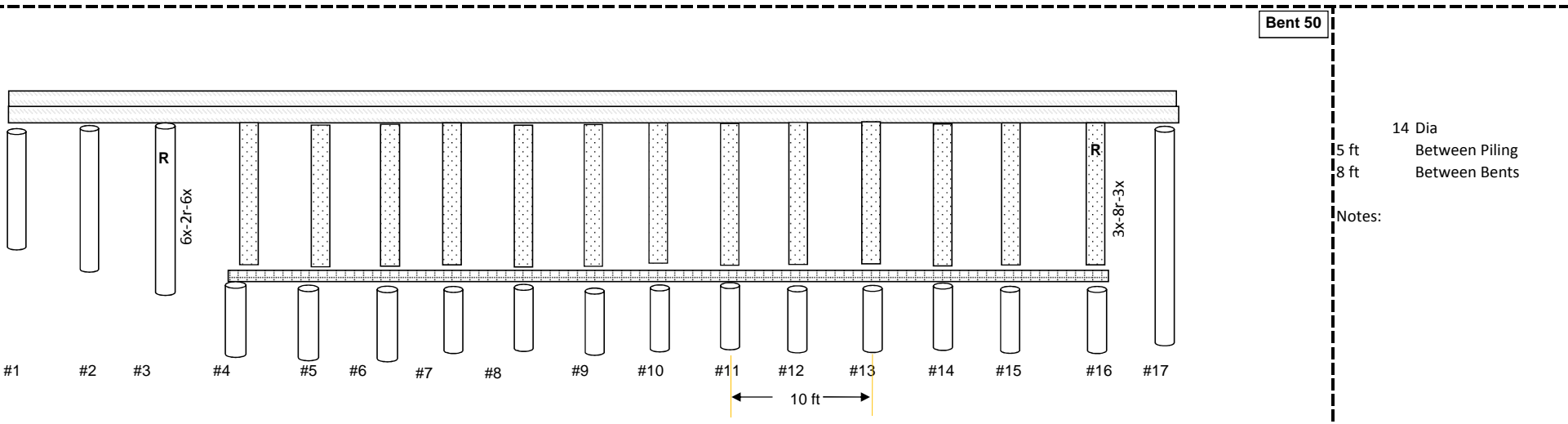
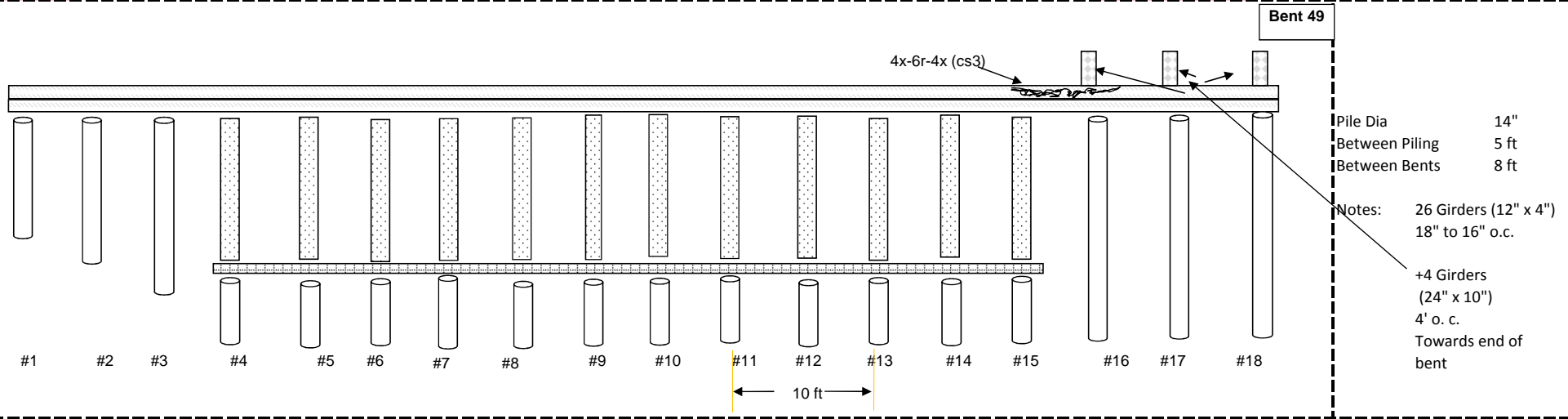

Bent 51

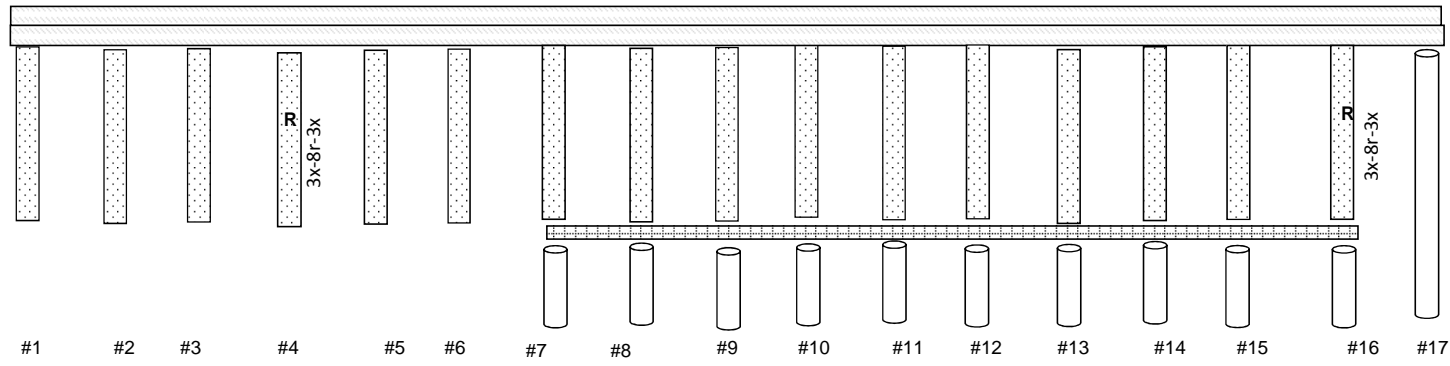

14"
5 ft
8 ft
Dia
Between Piling
Between Bents

Notes:

Bent 52

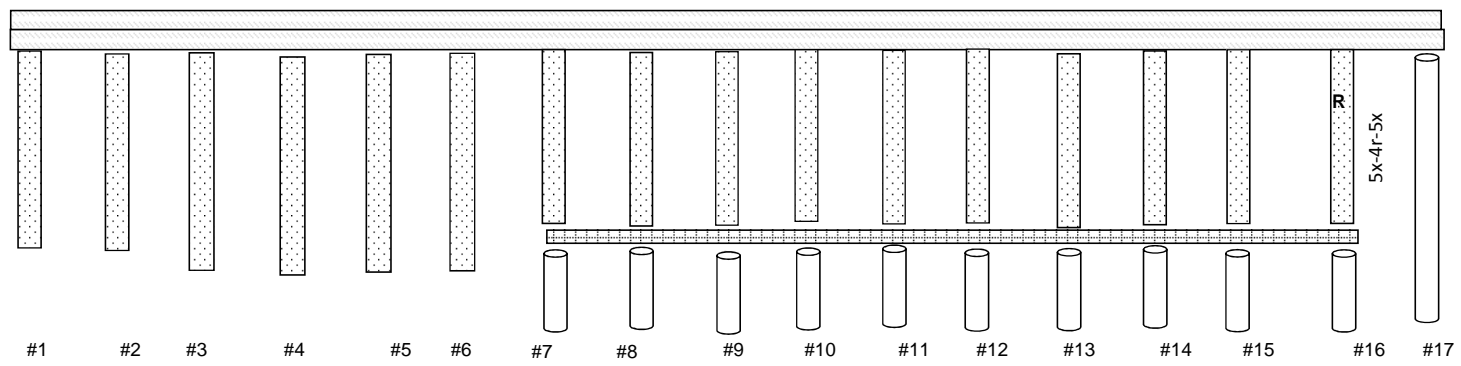

14"
5 ft
8 ft
Dia
Between Piling
Between Bents

Notes:

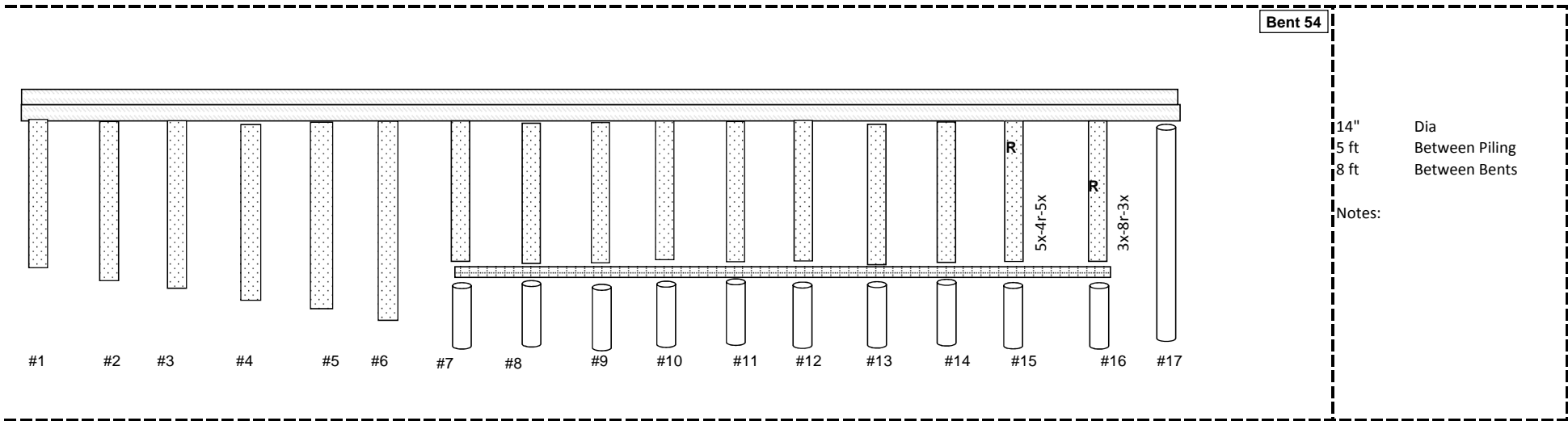
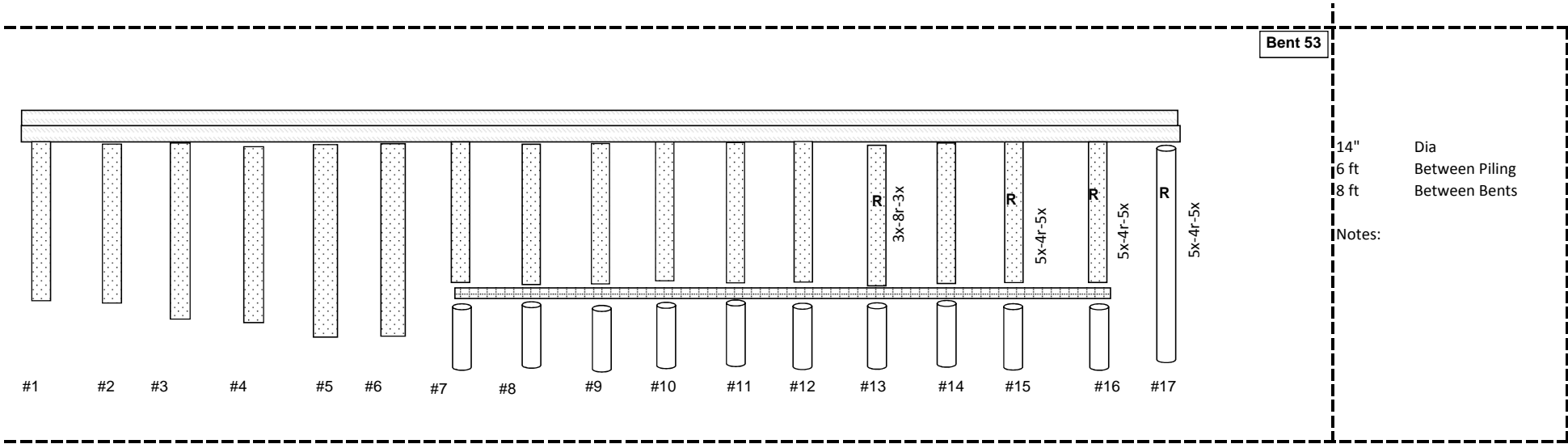

Bent 55

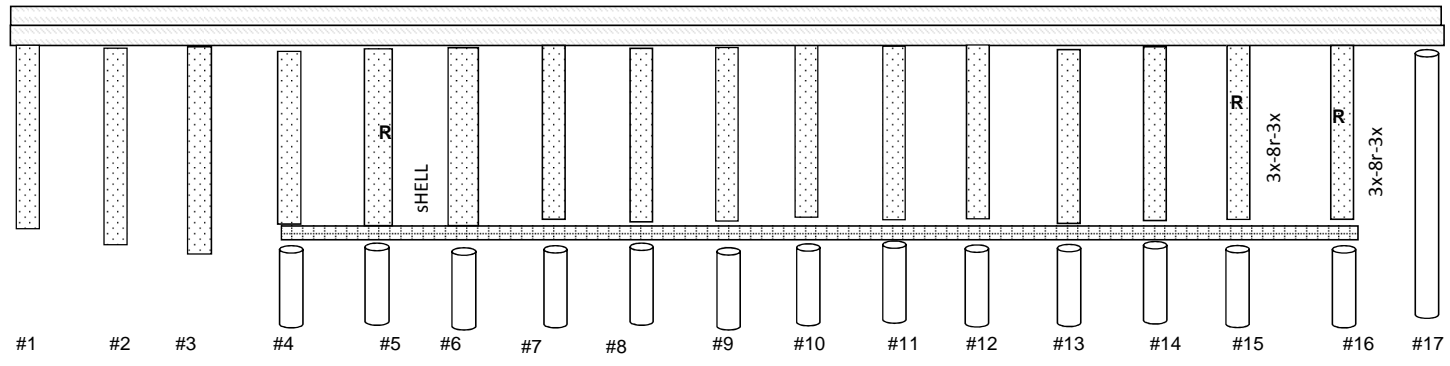

14"
5 ft
8 ft
Dia
Between Piling
Between Bents

Notes:

Bent 56

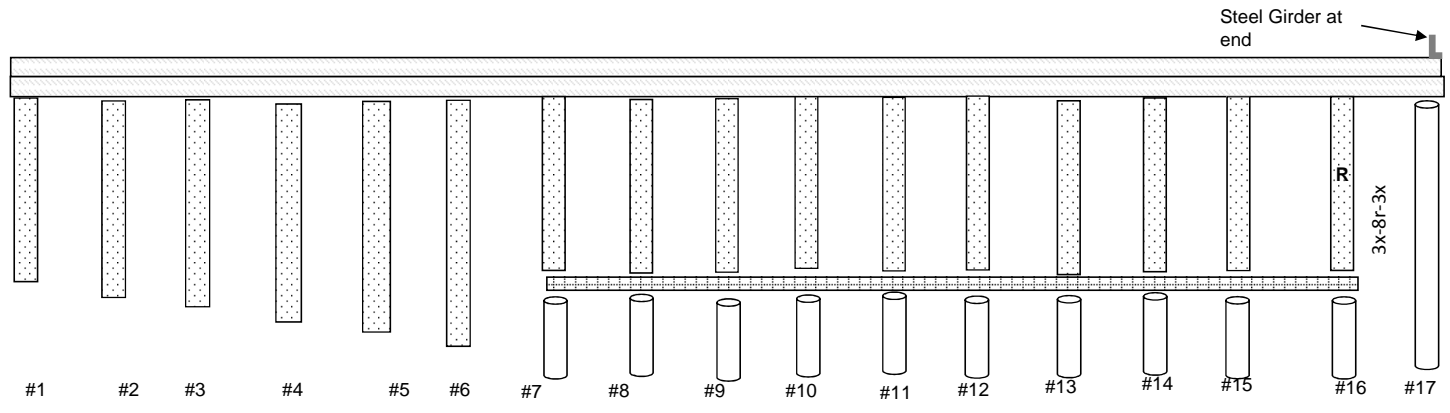

14"
5 ft
8 ft
Dia
Between Piling
Between Bents

Notes:

